

**IXIL**  
exhaust

Make **it** perfect



2020



4 COMPANY PROFILE

6 RACING

10 TUNING

**14 IXIL EXHAUST**

16 SX1

24 RC

32 RC1

40 RC1B

48 X55SB

54 MXT

62 L5X

68 L3XB

76 L3N

82 L2X

90 XOVE

98 SOVE

106 SCCL

**110 IXIL CARRERA**

112 VTI

**120 IRONHEAD**

122 HC2

132 HC2B

142 HC1

156 HC1B

170 OVC11

182 OVC13

**190 IXIL PARTS**

192 DKAT

**198 IXIL DESIGN**

200 WATERPROOF BAGS

**224 APPLICATIONS**



**IXIL** came onto the market in 1955, backed by a family business in the heart of Barcelona.

The constant efforts and determination of two generations to offer products with the best possible guarantees have been fundamental in obtaining world-wide recognition. Splendid teamwork in the manufacture, commercialization and distribution of the brand make us competitive in the international market.

The latest technology is used in all our production processes so that we can meet the highest European standards. Our product development is based on computer-assisted design (CAD), giving greater speed and high precision in adaptations.

The whole production process is computer supported, from the laser cutting machines to the welding robots.

IXIL takes part in the racing world and enjoys the confidence of world class competitors in the top Moto GP category.

where new materials and technologies are developed and tested in order to achieve maximum quality.

**IXIL** surgió en el mercado en 1.955 a través de una Empresa familiar en el corazón de Barcelona.

La constancia y el tesón de dos generaciones, con la voluntad de ofrecer siempre la máxima garantía en nuestros productos, han sido fundamentales para obtener un reconocimiento mundial, un gran trabajo de equipo en la fabricación, comercialización y distribución de la marca permite la competitividad en el mercado Internacional.

Los últimos avances tecnológicos están presentes en todos nuestros procesos de producción para permitir superar las más estrictas normativas europeas.

El desarrollo de los productos, tiene como base el diseño asistido por ordenador(CAD) el cual permite una mayor rapidez y una alta precisión en las adaptaciones.

Todo el proceso de producción esta apoyado informáticamente, desde las máquinas de corte por láser hasta los robots de soldadura.

IXIL está presente en el mundo de la competición donde cuenta con la confianza de pilotos de elite mundial, luchando en la categoría reina de Moto GP; donde se desarrollan y experimentan nuevos materiales y tecnologías con el fin de ofrecer la máxima calidad.

**IXIL** fit son apparition sur le marché du silencieux en 1955. C'est une Entreprise familiale située au coeur de Barcelone.

C'est au travers de deux générations jeunes et dynamiques et une volonté constante d'obtenir toujours la meilleure qualité que la marque IXIL se réjouit aujourd'hui d'avoir une reconnaissance mondiale.

C'est grâce à un important travail d'équipe en matière de fabrication, de commercialisation et de distribution qu'IXIL est présent sur le plan international.

Les derniers progrès technologiques sont présents tout au long du processus de fabrication permettant de dépasser les normes européennes les plus strictes.

La (CAD) conception assistée par ordinateur assure une plus grande précision dans nos projets et une meilleure rapidité d'exécution.

Tous les processus de fabrication sont assistés par ordinateurs, depuis les machines de coupes au laser jusqu'aux robots de soudures.

IXIL est présent dans le monde de la compétition où il bénéficie de la confiance de pilotes d'élite mondiale, luttant dans la catégorie reine du Moto GP. C'est dans la compétition que de nouveaux matériaux et de nouvelles technologies sont mises au point et testées dans le but d'offrir une qualité optimum à nos clients.

Als ein im Zentrum von Barcelona angesiedelter Familienbetrieb nahm **IXIL** im Jahre 1955 seine Geschäftstätigkeit auf.

Die Beharrlichkeit und Ausdauer, mit der sich zwei Generationen einer maximalen Qualität der angebotenen Erzeugnisse verschrieben, war die Grundlage für unsere heutige weltweite Anerkennung. Und durch einen ungebrochenen Teamgeist bei Herstellung, Vermarktung und Vertrieb der Marke ist es uns möglich, uns mit durchschlagendem Erfolg im internationalen Wettbewerb zu behaupten.

Die letzten technischen Fortschritte haben ihren Niederschlag in all unseren Produktionsverfahren gefunden, so daß den strengsten europäischen Normen voll Rechnung getragen werden kann.

Die Entwicklung unserer Produkte erfolgt computergestützt anhand der modernsten CAD-Verfahren, wodurch Zeit gespart und maximale Präzision bei all den verschiedenen Anwendungsbereichen erzielt wird.

Der gesamte Produktionsprozeß wird EDV-mäßig überwacht-von den Laserschneidmaschinen bis hin zu den Schweißautomaten.

IXIL ist im internationalen Rennsport bekannt und geschätzt und genießt das Vertrauen der weltweit besten Fahrer in der Moto GP-Klasse. Hier werden auch neue Materialklassen und technische Alternativen geprüft, um so stets und jederzeit maximale Qualität bieten zu können.

**IXIL** 品牌由一个家族企业于1955年在西班牙巴塞罗那成立。50多年来,通过两代企业领导人不断的努力,坚持提供最好的摩托车改装产品,得了全世界的认可。

我们是欧洲最大的改装摩托车排气管生产商,适配的车型从50CC到1400CC达到了上千种款式。在工厂的支持配合下,品牌的商业化和发行使我们在国际市场上享有很大竞争力我们在生产过程中运用最新的技术,确保产品达到最高的欧洲标准。所有产品运用电脑的(CAD)设计完成;从激光切割到机器焊接等,所有的生产流程都由电脑辅助控制,保证每个零件的性能得到最大的体现。

IXIL满怀信心活跃在赛车场上,在以先进的新材料和技术达到最好品质的世界顶级MOTOGP比赛行列里,我们享受着骑士带来的自信和荣誉!







# IXIL RACING

**IXIL Exhausts** esta presente en las carreras mas competitivas de todo el mundo desde 1955. Moto GP ha sido nuestro mayor laboratorio para ensayar nuestros productos, trabajando a codo a codo con los equipos mas relevantes. Desde WSBK hasta CSBK, Z CUP, WSSP300, CBR300CUP, NINJA 250CUP, NK250CUP y muchas otras competiciones de primer nivel, están apoyadas por IXIL Exhausts. Toda esta tecnología y experiencia en la competición, certifican todos nuestros productos.

**IXIL Exhausts** is present in the most competitive races around the world since 1955. Moto GP had been our biggest laboratory for test our products, working side by side with the most important teams. From WSBK to CSBK, Z CUP, WSSP300, CBR300CUP, NINJA250CUP, NK250CUP and many other competitions are powered by IXIL Exhausts. All this technology and experience on competition, certify all our products.

**IXIL Exhausts** est présent dans les courses les plus compétitives du monde entier depuis 1955. Moto GP a été notre plus grand laboratoire pour tester nos produits, travaillant aux côtés des plus grandes équipes. De la WSBK à la CSBK, en passant par la Z CUP, la WSSP300, la CBR300CUP, la NINJA250CUP, la NK250CUP et bien d'autres compétitions sont équipés par IXIL Exhausts. Toute cette technologie et cette expérience sur la compétition, certifient tous nos produits.

**IXIL Exhausts** ist seit 1955 in allen relevanten Motorradrennserien der Welt zu finden. Von WSBK zu CSBK, Z CUP, WSSP300, CBR300CUP, NINJA250CUP, NK250CUP und viele andere Rennserien sind powered by IXIL Exhausts. Alle Erfahrungen die dort erlangt wurden fließen in alle IXIL Produkte und werden so ständig weiter entwickelt.

自1955年以来，**IXIL**排气管一直出现在世界上竞争最激烈的赛事中。摩托GP是测试我们产品最大的实验室，作为供应商，我们与最具影响力的车队并肩作战。从WSBK到CSBK，Z CUP，WSSP300，CBR300CUP，NINJA250CUP，NK250CUP及许多其他一级赛事，均由IXIL Exhausts提供支持。这些在赛事中不断积累的技术和经验是我们所有产品的质量保证。





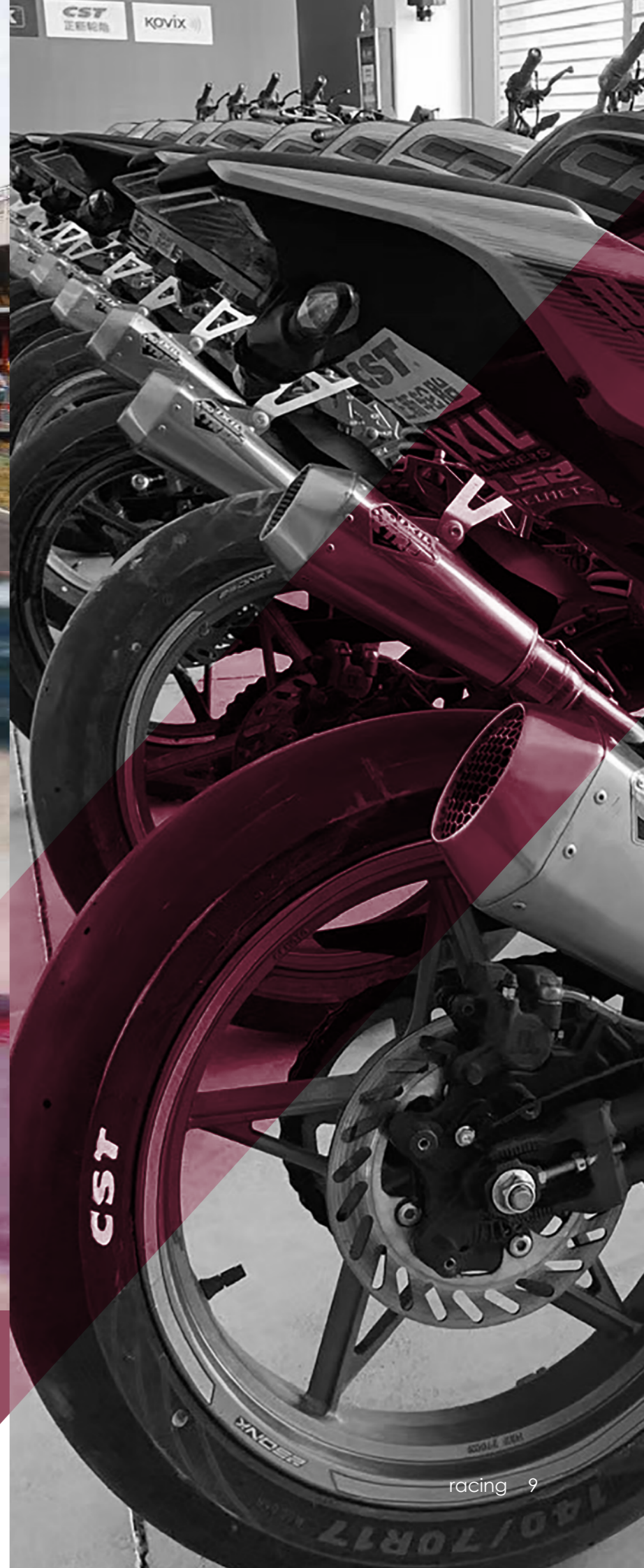





# IXIL TUNING

La extensa gama de productos **IXIL** con diseños innovadores, siempre han contado con la confianza de grandes preparadores de motocicletas. El diseño vanguardista de nuestros productos, hace perfecto el equilibrio entre la belleza y la potencia.

The large range of **IXIL** products with innovative designs, always had the confidence of the best custom bikes professionals. The advanced design of our products, makes perfect the balance between beauty and power.

La grande gamme de produits **IXIL** avec des designs innovants, a toujours eu la confiance des meilleurs professionnels de la customisation. Le design avancé de nos produits, rend parfait l'équilibre entre la beauté et la performance.

Die große Vielfalt der **IXIL** Produkte mit ihrem innovativem Design genießt das Vertrauen vieler Customizer der Motorradszene. Das fortschrittliche Design unserer Produkte vereint die Balance zwischen Schönheit und optimaler Leistung.

我们产品的前卫设计使美观与力量之间达到完美平衡。**IXIL** 的产品种类多样，设计新颖，是摩托车专业涂装修理的放心之选。我们产品的前卫设计是美观与力量的完美平衡。









**IXIL**  
exhaust





# SX1 - Exhaust Line

Super Xtreme



## TECHNICAL DATA

Silenciador fabricado en acero inoxidable AISI 304 en acabado satinado mate. Tapa de salida y protector fabricado en fibra de carbono resinado en epoxy de alta temperatura con acabado negro brillante.

Silencer manufactured from AISI304 stainless steel with a satin polished finish. End cap and protector manufactured from high temperature carbon fiber epoxy resin with bright polished finish.

Silencieux fabriqué en acier inoxydable AISI304 et soudures TIG.  
La sortie de gaz et le protecteur thermique sont fabriqués en carbone haute température.

Ein aus rostfreiem AISI304 stahl hergestellter schalldämpfer mit einer seidenmatt polierten oberfläche.  
Sowohl die endkappe als auch teile des schalldämpfers zeichnen sich durch einen aus edlem carbon gefertigten hitzeschutz aus.

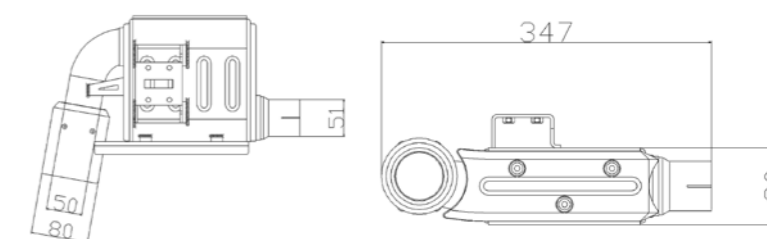



**SX1 - Exhaust Line**  
Super Xtreme

HONDA - CB 650 F



HONDA - CB1000R



HONDA - CBR 650 F



KAWASAKI - NINJA 650





KAWASAKI - VULCAN S



**SX1** - Exhaust Line  
Super Xtreme

KAWASAKI - VERSYS 1000



KAWASAKI - Z1000

KAWASAKI - Z900







**SX1** - Exhaust Line  
Super Xtreme



YAMAHA - MT07



YAMAHA - MT09 TRACER



SUZUKI - GSX1000S

ZONTES - V310





**RC - Exhaust Line**  
Race Xtrem

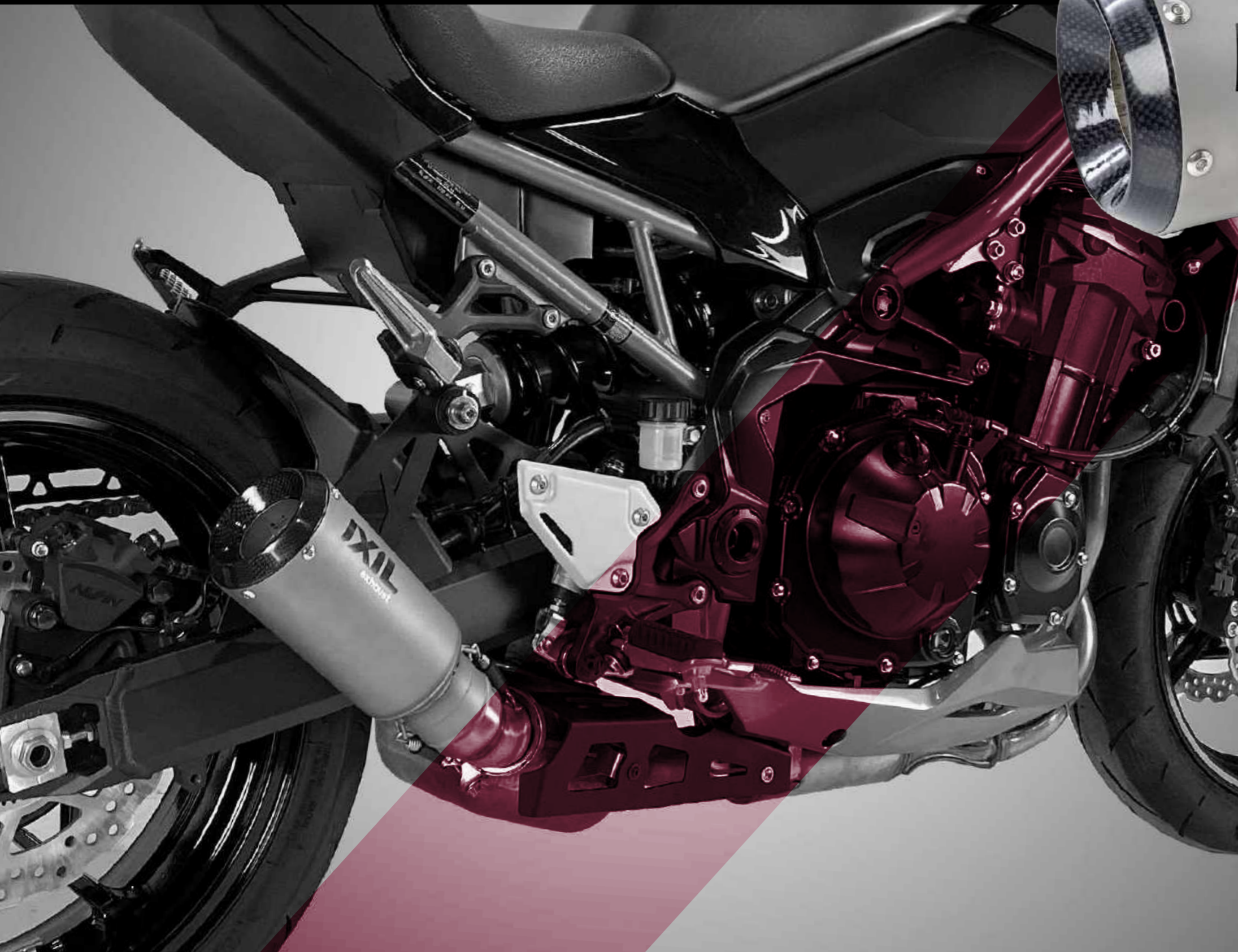

**TECHNICAL DATA**

Silenciador fabricado en acero inoxidable AISI 304 en acabado satinado TITANIUM Look. Tapa de salida cónica fabricada en fibra de carbono resinada en epoxi de alta temperatura con acabado brillante.

Silencer made on stainless Steel AISI 304 with satin TITANIUM look finish. Conical end cap manufactured from carbon fiber epoxi resin with bright finish.

Silencieux fabrique en acier inoxydable AISI 304 finition satiné TITANIUM Look. Sortie de gaz conique fabrique a partir de résine époxy de fibre de carbone a haute température avec une finition brillante.

Der Schalldämpfer, der im Edelstahl hergestellt wurde, beendete AISI 304 im satinehilfen TITANIUM Look. Konische hitzebeständige carbon endkappe in glänzendem finish.

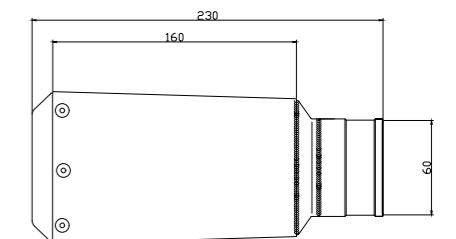
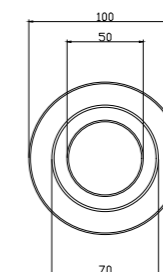



**RC - Exhaust Line**  
Race Xtrem

CF MOTO - NK400



HONDA - CB1000R



HONDA - CBR1000RR



KAWASAKI - ZX10R





KTM - 790 ADVENTURE



**RC - Exhaust Line**  
Race Xtrem

KTM - DUKE 790



KTM - SUPERDUKE 1290



SUZUKI - KATANA







**RC - Exhaust Line**  
Race Xtrem



VOGE - 500R

SUZUKI - GSXR 1000



YAMAHA - MT07



YAMAHA - MT09





# RC1 - Exhaust Line

Race Hexacone Xtrem



### TECHNICAL DATA

Silenciador fabricado en acero inoxidable AISI 304 en acabado satinado mate. Tapa de salida "BIG FLOW" fabricada en acero inoxidable AISI 304 en acabado satinado mate.

Silencer made on stainless Steel AISI 304 with satin mate finish.  
End cap "BIG FLOW" made on stainless Steel AISI 304 with satin matt finish.

Der Schalldämpfer, der im Edelstahl hergestellt wurde, beendete AISI 304 im Satingehilfen. Abdeckung des Ausganges "GROSSER FLUSS" im Edelstahl hergestellt wurde, beendete AISI 304 im Satingehilfen.

Silencieux fabriqué en acier inoxydable AISI 304. Finition satinée mate.  
Sortie de Gaz "BIG FLOW" fabriqué en acier inoxydable AISI 304.

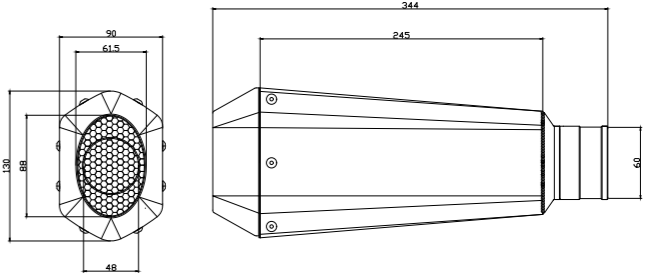



**RC1 - Exhaust Line**  
Race Hexacone Xtrem

BENELLI - BN502 C



BENELLI - LEONCINO 250



BENELLI - TRK 502



BMW - S1000XR





HONDA - CB300R



**RC1 - Exhaust Line**  
Race Hexacone Xtrem

HONDA - CB1000R



HONDA - X-ADV 750



KAWASAKI - H2 SX







**RC1** - Exhaust Line  
Race Hexacone Xtrem



KAWASAKI - Z900RS

KAWASAKI - NINJA 400



SUZUKI - GSX-R 125



YAMAHA - MT10





# RC1B - Exhaust Line

Race Hexacone Xtrem Black



## TECHNICAL DATA

Silenciador fabricado en acero inoxidable AISI 304 con acabado lacado negro. Tapa salida BIG FLOW fabricada en acero inoxidable AISI 304 con acabado lacado negro.

Silencer made on stainless Steel AISI 304 with black lacquer finish.  
End cap "BIG FLOW" made on stainless Steel AISI 304 with black lacquer finish.

Schalldämpfer aus Edelstahl AISI 304 mit Schwarz lackiert.  
Abdeckung des Ausganges GROSSER FLUSS im Edelstahl AISI 304 mit Schwarz lackiert.

Silencieux laqué noir fabriqué en acier inoxydable AISI 304 laque noir. La sortie de gaz BIG FLOW fabriqué en acier inoxydable AISI 304 laque noir.

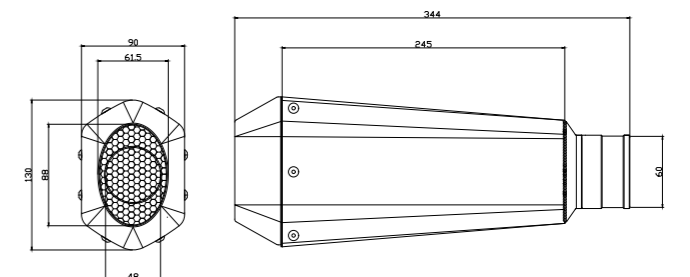



**RC1 - Exhaust Line**  
Race Hexacone Xtrem Black

HONDA - CB 500 F



HONDA - X-ADV 750



KAWASAKI - NINJA 400



KAWASAKI - Z1000R



exhaust - RC1B Line 43



KAWASAKI - Z1000SX



**RC1B - Exhaust Line**  
Race Hexacone Xtrem Black

KTM - DUKE 790



KTM - RC 390



SUZUKI - GSXR 125







**RC1B - Exhaust Line**  
Race Hexacone Xtrem Black



YAMAHA - MT07

SUZUKI - GSXS750



YAMAHA - XSR900



YAMAHA - R1





## X55SB - Exhaust Line

Slash Cone Xtrem Black

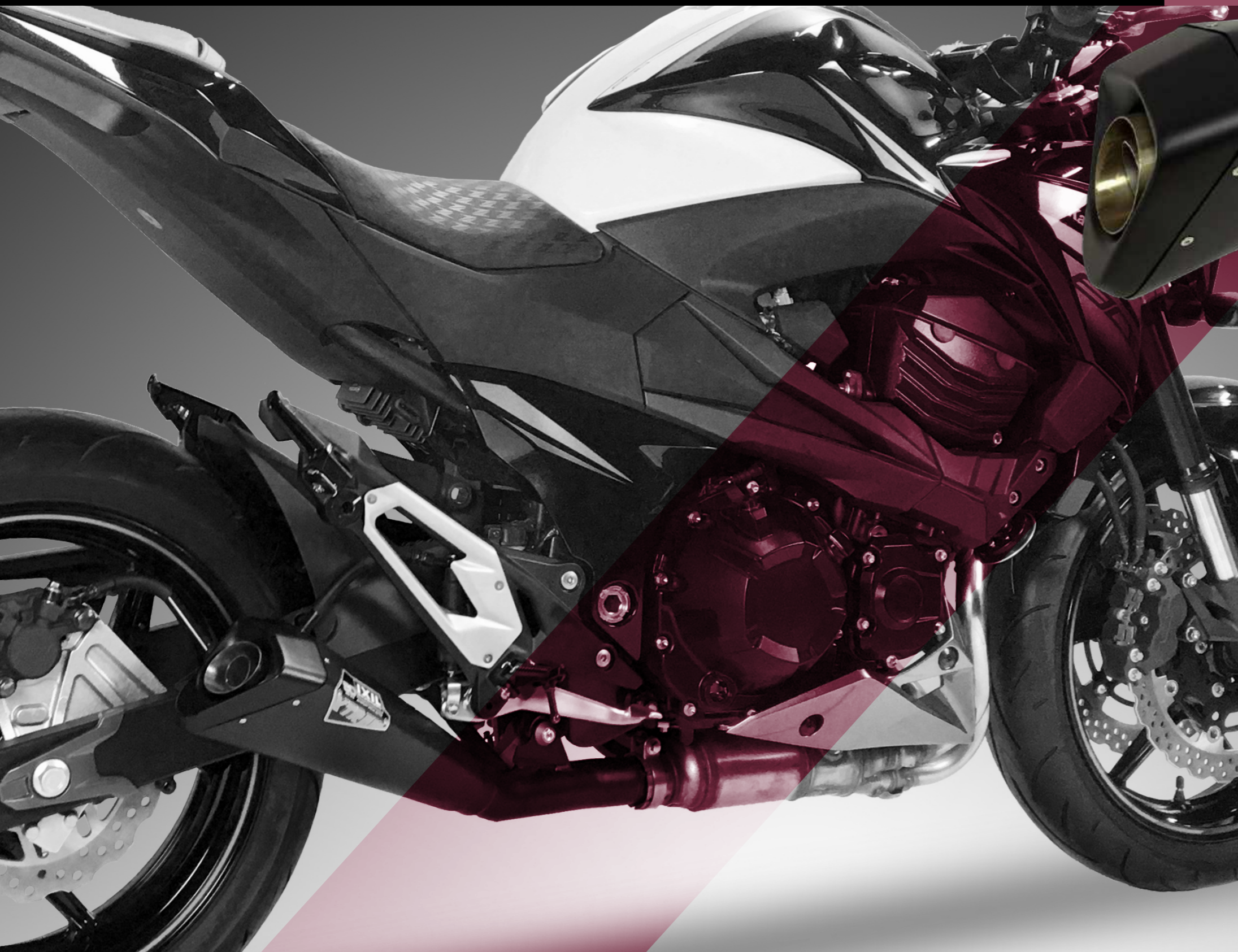

### TECHNICAL DATA

Silenciador fabricado en acero inoxidable AISI 304 con acabado lacado negro. Tapa salida "BIG FLOW" fabricada en acero inoxidable AISI 304 con acabado lacado negro.

Silencer manufactured from AISI 304 stainless steel with black lacquer finish. End cap "BIG FLOW" manufactured from AISI 304 stainless steel with black lacquer finish.

Schalldämpfer aus Edelstahl AISI 304 mit Schwarz lackiert. Abdeckung des Ausganges GROSSER FLUSS im Edelstahl AISI 304 mit Schwarz lackiert.

Silencieux laqué noir fabriqué en acier inoxydable AISI 304 laque noir. La sortie de gaz "BIG FLOW" fabriqué en acier inoxydable AISI 304 laque noir.

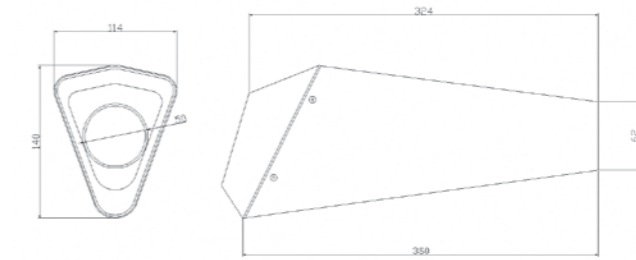



**X55SB - Exhaust Line**  
Slash Cone Xtrem Black

HONDA - NC750



KAWASAKI - VERSYS 650



KAWASAKI - NINJA 650



KAWASAKI - Z800





KAWASAKI - Z800



**X55SB** - Exhaust Line  
Slash Cone Xtrem Black

KAWASAKI - Z900



YAMAHA - MT10

KAWASAKI - Z1000



exhaust - X55SB Line 53



**MXT - Exhaust Line**  
Mega Xtrem



**TECHNICAL DATA**

Silenciador fabricado en acero inoxidable AISI 304 con acabado satinado mate. Tapa de salida asimétrica fabricada en aluminio inyectado con acabado lacado negro.

Silencer manufactured from AISI 304 stainless steel with a satin polished finish. Asymmetric and conical end cap, manufactured in aluminium with high temperature black lacquer.

Silencieux fabriqué en acier inoxydable AISI 304 avec finition satinée mate. Sans entretien et sonorité apaisée. Sortie de gaz conique et asymétrique fabriquée en aluminium injecté laqué noir.

Ein aus rostfreiem AISI 304 Stahl hergestellter Schalldämpfer mit einer seidenmatt polierten Oberfläche. Die aus Aluminium gefertigte asymmetrische und konische Endkappe wurde mit einer hitzebeständigen, schwarzen Lackierung vollendet.

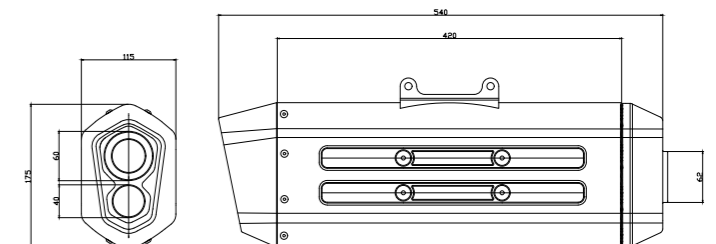



**MXT - Exhaust Line**  
Mega Xtrem

BMW - R1250GS



BMW - R1250GS



HONDA - CRF1000 AFRICA TWIN



HONDA - CRF1000 AFRICA TWIN



exhaust - MXT Line 57



KTM - 1290 ADVENTURE



KTM - 1290 ADVENTURE



SUZUKI - V-STROM 650



**MXT** - Exhaust Line  
Mega Xtrem



SUZUKI - V-STROM 650







**MXT** - Exhaust Line  
Mega Xtrem



SUZUKI - V-STROM 1000

SUZUKI - V-STROM 1000



TRIUMPH - TIGER 1200



TRIUMPH - TIGER 1200





# L5X - Exhaust Line

Dual Hyperlow XXL



## TECHNICAL DATA

Silenciador fabricado en acero inoxidable AISI 304 con acabado satinado mate. Tapa salida fabricada en acero inoxidable AISI 304 en acabado satinado mate.

Silencer manufactured from AISI304 stainless steel with a satin polished finish. End caps made from AISI304 stainless steel with a satin polished finish.

Silencieux fabriqué en acier inoxydable AISI 304 avec finition satiné mate. Sorties de gaz en acier inoxydable AISI 304 avec finition satiné mate.

Ein aus rostfreiem AISI304 stahl hergestellter schalldämpfer mit einer seidenmatt polierten oberfläche.

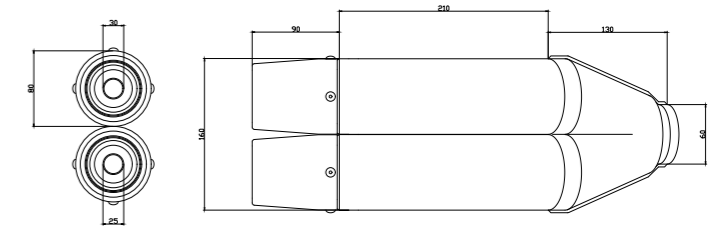



**L5X - Exhaust Line**  
Dual Hyperlow XXL

BMW - C650 SPORT



KYMCO - XCITING 300



KYMCO - XCTING 400



KYMCO - AK550



exhaust - L5X Line 65





**L5X** - Exhaust Line  
Dual Hyperlow XXL



VESPA - GTS 300 SUPER



KYMCO - AK550



YAMAHA - T-MAX 530





## L3XB - Exhaust Line

Dual Hyperlow Black XL

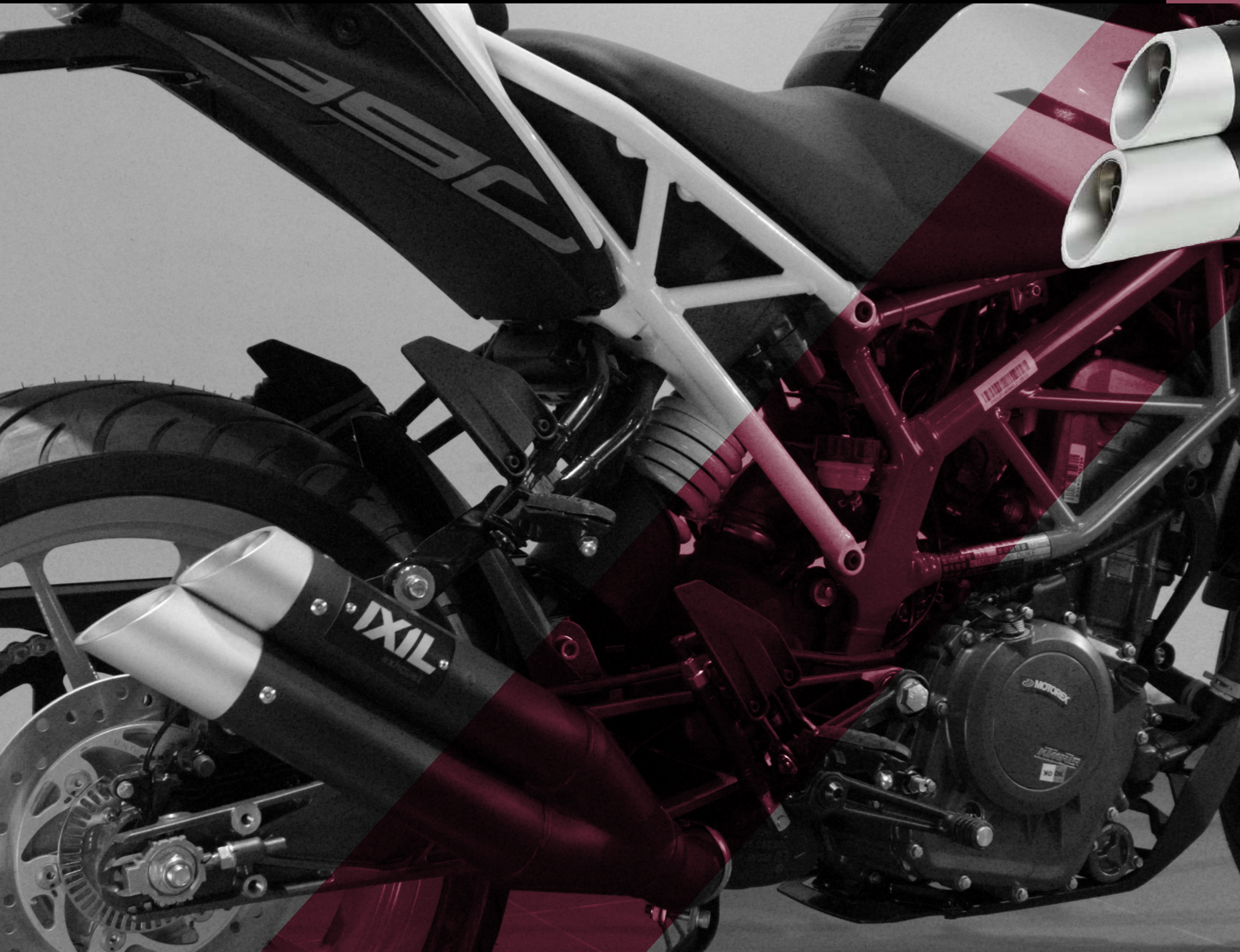

### TECHNICAL DATA

Silenciador fabricado en acero inoxidable AISI 304 con acabado lacado negro. Tapa salida fabricada en aluminio CNC anodizado mate.

Silencer manufactured from AISI 304 stainless steel with black lacquer finish. End caps made in aluminum with matt anodizing finish.

Silencieux fabriqué en acier inoxydable AISI 304 avec finition laqué noire. Sorties de gaz en aluminium CNC anodisé gris.

Ein aus rostfreiem AISI304 stahl hergestellter schalldämpfer mit einer schwarzen lackierung. Die aus aluminium gefertigten endkappen zeichnen sich durch eine matte eloxierte oberfläche aus.

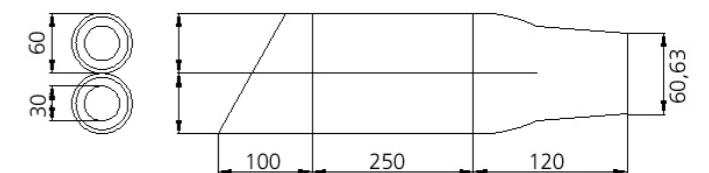



**L3XB - Exhaust Line**  
Dual Hyperlow Black XL

HONDA - CB500



HONDA - CB650F



HONDA - NC 750 X



HONDA - VFR800X CROSSRUNNER







KAWASAKI - Z800



**L3XB** - Exhaust Line  
Dual Hyperlow Black XL



KAWASAKI - NINJA 650



KAWASAKI - Z900e



KAWASAKI - Z650



exhaust - L3XB Line 73





**L3XB - Exhaust Line**  
Dual Hyperlow Black XL



KTM - RC390



SUZUKI - GSX750S



YAMAHA - MT07

YAMAHA - MT09





# L3N - Exhaust Line

Dual Xtrem

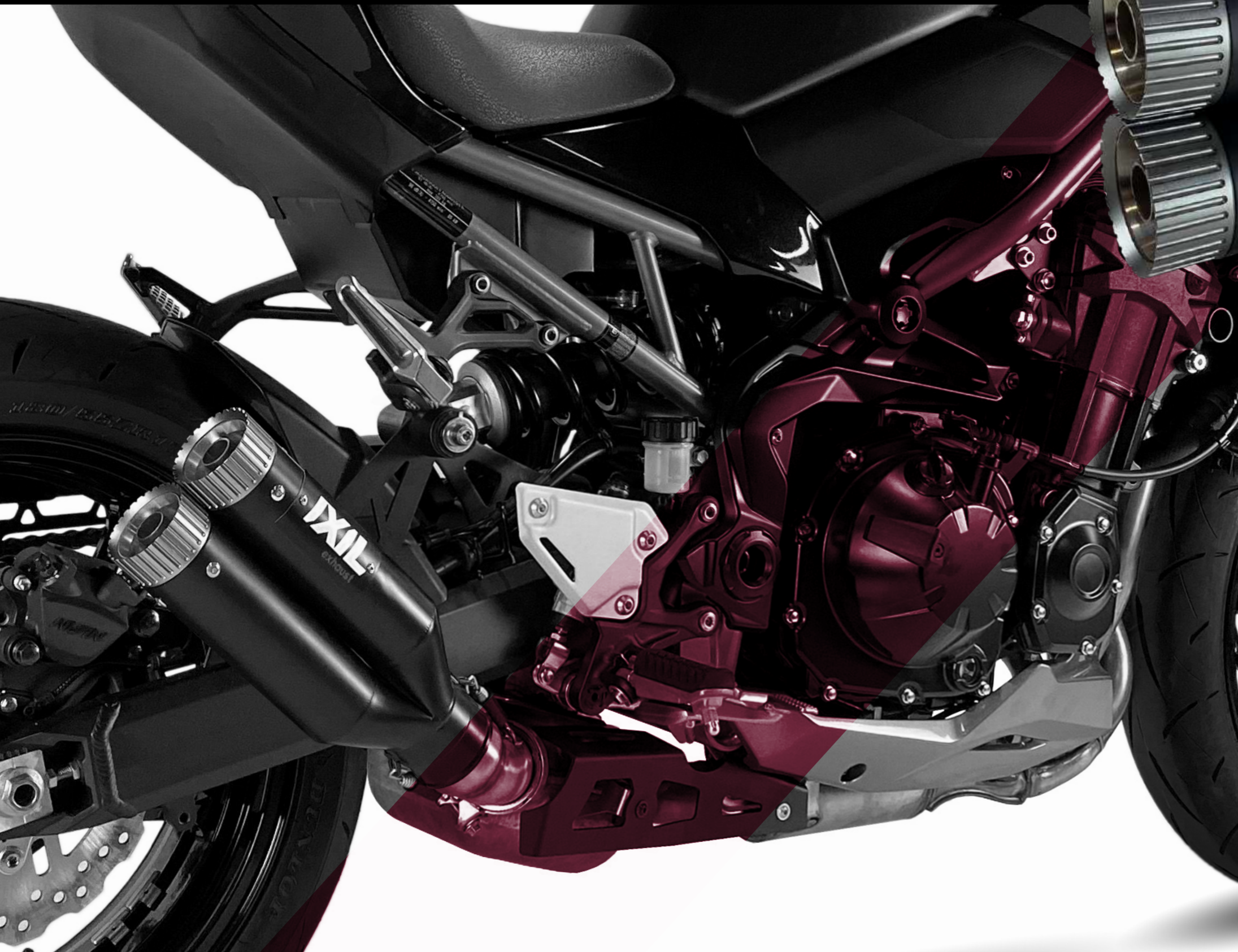

## TECHNICAL DATA

Silenciador fabricado en acero inoxidable AISI 304 con acabado lacado negro. Tapa de salida fabricada en aluminio CNC anodizado mate.

Silencer manufactured from AISI 304 stainless Steel with black lacquer finish. End caps made in aluminium CNC with matt anodizing finish.

Silencieux fabrique en acier inoxydable AISI 304 avec finition laque noire. Sorties de gaz en aluminium CNC anodize gris.

Ein aus rostfreiem AISI 304 stahl hergestellter schalldampfer mit einer schwarzen lackierung. Die aus aluminium CNC gefertigten endkappen zeichnen sich durch eine matte eloxierte oberfläche aus.

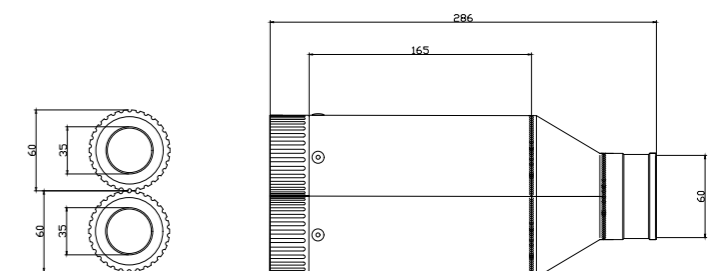



**L3N - Exhaust Line**  
Dual Xtrem

HONDA - CB1000R



HONDA - CB300R



KAWASAKI - NINJA 400



KAWASAKI - Z900





KTM - DUKE 790



**L3N** - Exhaust Line  
Dual Xtrem

KTM - DUKE 390



SUZUKI - GSX-S 750

KTM - 790 ADVENTURE



exhaust - L3N Line 81



## L2X - Exhaust Line

Dual Hyperlow

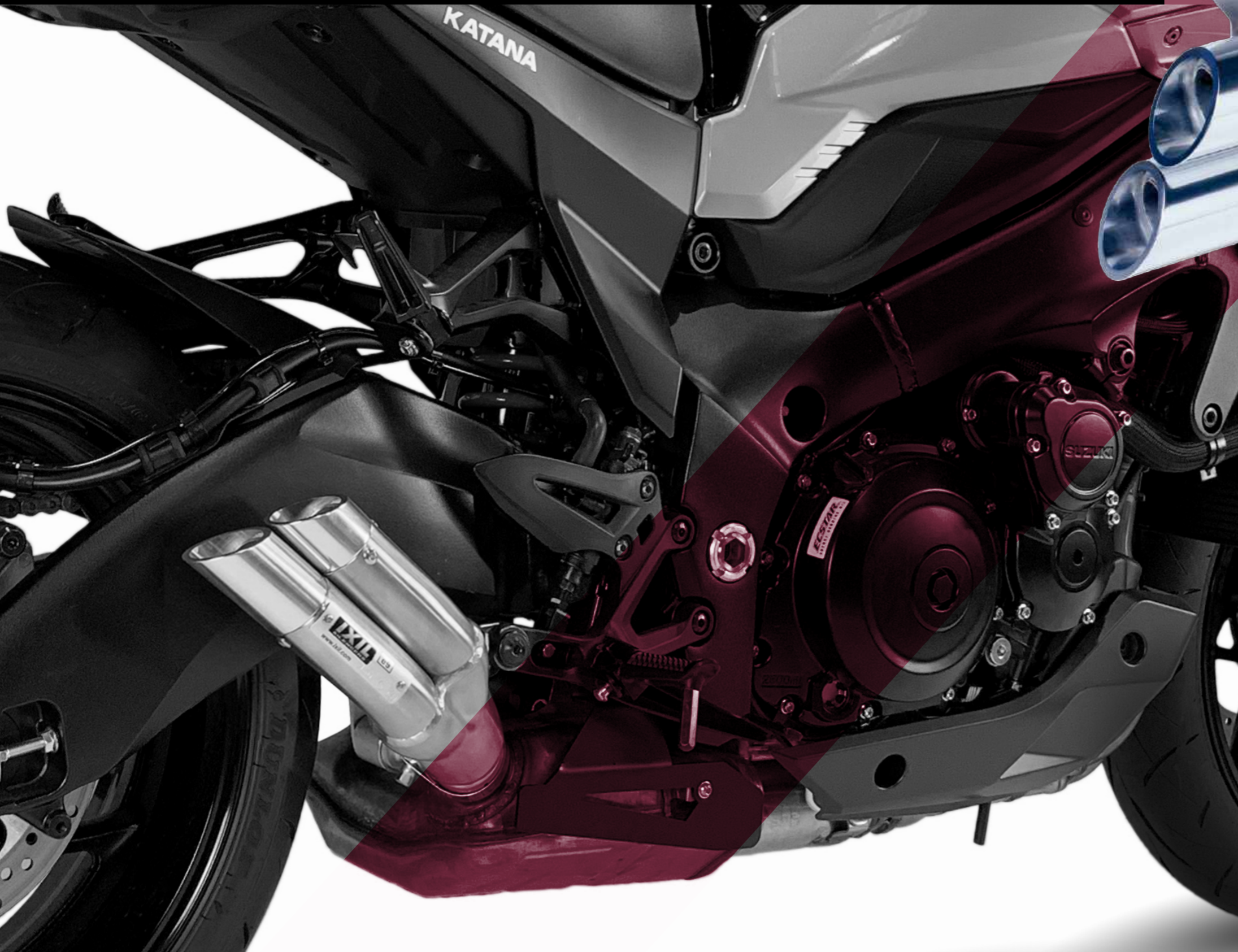

### TECHNICAL DATA

Silenciador fabricado en acero inoxidable AISI304 con acabado satinado mate. Tapa de salida fabricada en aluminio anodizado brillante.

Silencer manufactured from AISI304 stainless steel with a satin polished finish. End caps made in aluminum with bright anodizing finish.

Silencieux fabriqué en acier inoxydable AISI304 avec finition satiné mate. Sorties de gaz en aluminium anodisé brillant.

Ein aus rostfreiem AISI304 stahl hergestellter schalldämpfer mit einer seidenmatt polierten oberfläche. Die aus aluminium gefertigten endkappen zeichnen sich durch eine glänzende eloxierte oberfläche aus.

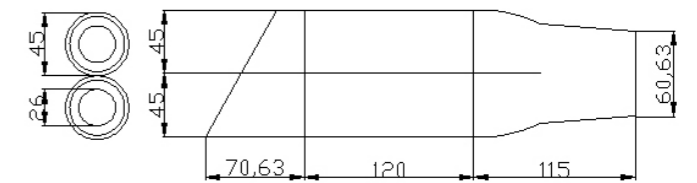



**L2X - Exhaust Line**  
Dual Hyperlow

HONDA - CB 600 F HORNET



HONDA - CB 1000 R



HONDA - CBR 125



HONDA - CBR 600 F





HONDA - MONKEY



L2X - Exhaust Line  
Dual Hyperlow

KAWASAKI - Z750



KAWASAKI - Z1000



KAWASAKI - ZX6R



exhaust - L2X Line 87





**L2X** - Exhaust Line  
Dual Hyperlow



SUZUKI - GSF 650 GLADIUS



KAWASAKI - ZX10R



SUZUKI - GSXR 600-750

SUZUKI - GSX-S 1000





# XOVE - Exhaust Line

Hexoval Xtrem Black

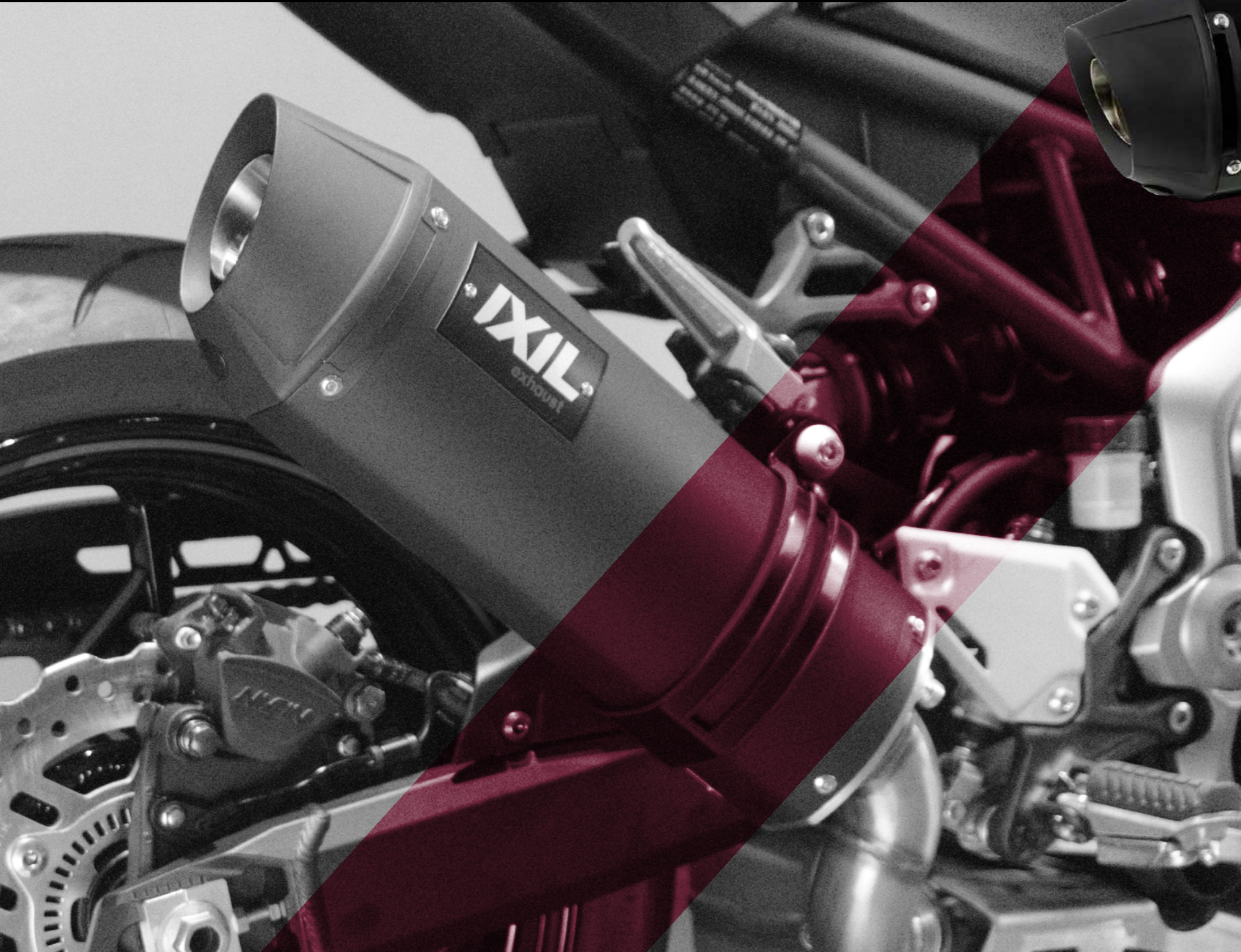

## TECHNICAL DATA

Silenciador fabricado en acero inoxidable AISI304 con acabado lacado negro. Tapa de salida cónica asimétrica fabricada en aluminio inyectado con acabado lacado negro.

Silencer manufactured from AISI304 stainless steel with black lacquer finish. Asymmetric and conical end cap, manufactured in aluminum with high temperature black lacquer.

Silencieux fabriqué en acier inoxydable AISI304 avec finition laqué noire.  
Sans entretien et sonorité maîtrisée. Sortie de gaz conique et asymétrique fabriqué en aluminium injecté laqué noire.

Ein aus rostfreiem AISI304 stahl hergestellter schalldämpfer mit einer schwarzen lackierung. Die aus aluminium gefertigte asymetrische und konische endkappe wurde mit einer hitzebeständigen schwarzen lackierung vollendet.





**XOVE - Exhaust Line**  
Hexoval Xtrem Black

HONDA - VFR 800X CROSSRUNNER



HONDA - VFR 800F



HONDA - CB 600F HORNET



KAWASAKI - NINJA 650





KAWASAKI - Z1000SX



**XOVE** - Exhaust Line  
Hexoval Xtrem Black



KAWASAKI - VERSYS 650



KTM - SUPERDUKE 1290

KAWASAKI - Z900







**XOVE** - Exhaust Line  
Hexoval Xtrem Black



SUZUKI - SV650



SUZUKI - GSX-S 750



KTM - DUKE 390

YAMAHA - MT125





# SOVE - Exhaust Line

Hexoval Xtreme Evolution

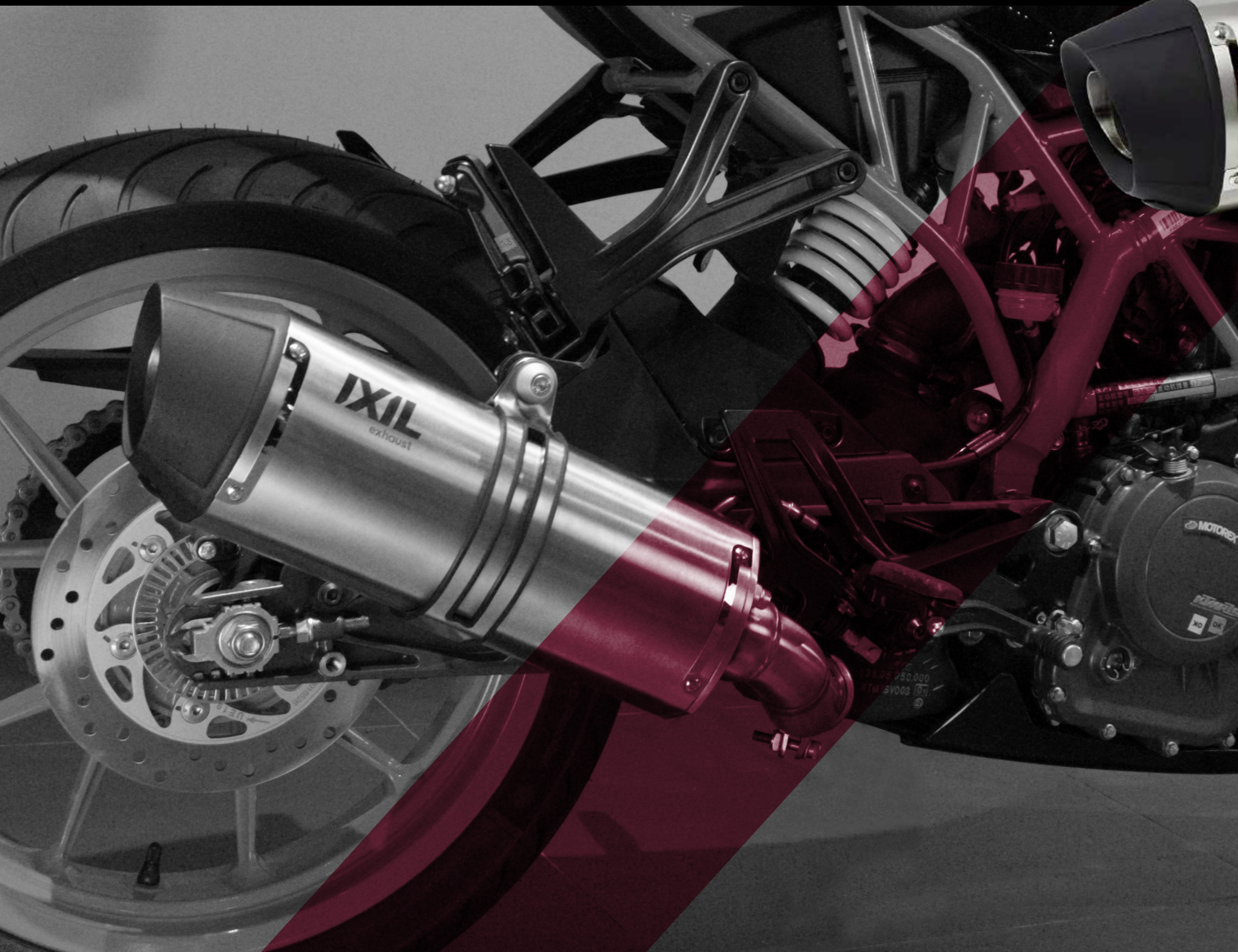

## TECHNICAL DATA

Silenciador fabricado en acero inoxidable AISI304 con acabado satinado mate. Tapa de salida cónica asimétrica fabricada en aluminio inyectado con acabado lacado negro.

Silencer manufactured from AISI304 stainless steel with a satin polished finish. Asymmetric and conical end cap, manufactured in aluminum with high temperature black lacquer.

Silencieux fabriqué en acier inoxydable AISI304 avec finition satiné mate. Sans entretien et sonorité maîtrisée. Sortie de gaz conique et asymétrique fabriqué en aluminium injecté laqué noir.

Ein aus rostfreiem AISI304 stahl hergestellter Schalldämpfer mit einer seidenmatt polierten Oberfläche.  
Die aus aluminium gefertigte asymmetrische und konische endkappe wurde mit einer hitzebeständigen schwarzen lackierung vollendet.





**SOVE - Exhaust Line**  
Hexoval Xtreme Evolution

HONDA - CBR 250 R



HONDA - CB 600 F HORNET



HONDA - NC 700 S



HONDA - CROSSRUNNER 800







KAWASAKI - ZX636



**SOVE** - Exhaust Line  
Hexoval Xtreme Evolution



KAWASAKI - Z800



SUZUKI - GSXR 600-750

KAWASAKI - Z900





**IXIL**  
exhaust

**SOVE** - Exhaust Line  
Hexoval Xtreme Evolution



SUZUKI - SV650



SUZUKI - GSR750



YAMAHA - MT09

YAMAHA - FZ1





## SCCL - Exhaust Line

2-Stroke Scooter



### TECHNICAL DATA

Silenciador fabricado en acero AP04 con acabado pintado negro.  
Tapa de salida cónica fabricada en acero AP04 con acabado pintado negro.

Silencer manufactured from AP04 steel with a black paint finish.  
Conical end cap manufactured from AP04 steel with black paint finish.

Silencieux fabriqué en acier type AP04 laquée noir.  
Sortie de gaz conique fabriqué en acier type AP04 laquée noir.

Ein aus AP04 stahl hergestellter schalldämpfer mit einer schwarz lackierten oberfläche.  
Abgerundet wird der Look durch die schwarz lackierte konische endkappe, die ebenfalls aus AP04 stahl gefertigt ist.

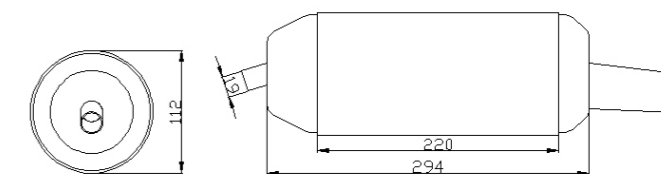





**SCCL - Exhaust Line**  
2-Stroke Scooter



PIAGGIO - ZIP



PIAGGIO - ZIP SP

PEUGEOT - LUDIX 50





# IXIL

carrera





**VTI - Carrera Line**  
Hexoval Xtreme Titanium



**TECHNICAL DATA**

Silenciador fabricado en TITANIO. Tapa de salida cónica asimétrica fabricada en fibra de carbono resinada en epoxi de alta temperatura con acabado brillante.

Silencer manufactured from TITANIUM. Asymmetric and conical end cap manufactured from high temperature carbon fiber epoxy resin with bright finish.

Silencieux fabriqué en TITANE. Embout asymétrique et conique fabriqué à partir de résine époxy de fibre de carbone à haute température avec une finition brillante.

Auspuff hergestellt aus TITAN. Asymetrische und konische, hitzebeständige Carbon Endkappe in glänzendem finish.





**VTI - Carrera Line**  
Hexoval Xtreme Titanium

APRILIA - TUONO V4 1100



HONDA - CB500F



HONDA - NC750X



HONDA - X-ADV 750



carrera - VTI Line 115



KAWASAKI - NINJA 400



**VTI - Carrera Line**  
Hexoval Xtreme Titanium

KAWASAKI - NJA H2



KAWASAKI - Z900

KAWASAKI - ZX10R



carrera - VTI Line 117





**VTI - Carrera Line**  
Hexoval Xtreme Titanium



SUZUKI - GSR 750



KAWASAKI - ZX636



SUZUKI - GSX-S 750

YAMAHA - R3





# IRONHEAD

by **IXIL**





## HC2 - Ironhead Line



### TECHNICAL DATA

Silenciador fabricado en acero inoxidable AISI 304 con acabado cromado y logotipo marcado con Laser.

Tapa de salida adaptable en 4 posiciones, fabricada en acero inoxidable AISI 304 con acabado cromado.

Silencer manufactured from AISI 304 stainless Steel with chrome finish and Laser print Logo.

Exit cover adjustable in 4 positions, manufactured from AISI 304 stainless Steel with chrome finish.

Schalldämpfer aus Edelstahl AISI 304 mit Chrom und Laser logo.

Umfassen sie den Ausgang in vier positionen verstellbar aus Edelstahl AISI 304 mit Chrom.

Silencieux fabrique en acier inoxydable AISI 304 avec une finition chrome et un marquage du logo a Laser.  
Sortie réglables en quatre posotions fabrique en acier inoxydable AISI 304 avec une finition chrome.







STREET 750



**HC2 - Ironhead Line**  
HARLEY DAVIDSON



STREET 750



TOURING ROAD KING



TOURING ROAD KING





**HC2 - Ironhead Line**  
HARLEY DAVIDSON



TOURING STREET GLIDE CVO



TOURING ULTRA LIMITED

TOURING ULTRA LIMITED

TOURING STREET GLIDE CVO





CHIEFTAIN



HC2 - Ironhead Line  
INDIAN

DARK HORSE



CHIEFTAIN



DARK HORSE









## HC2B - Ironhead Line

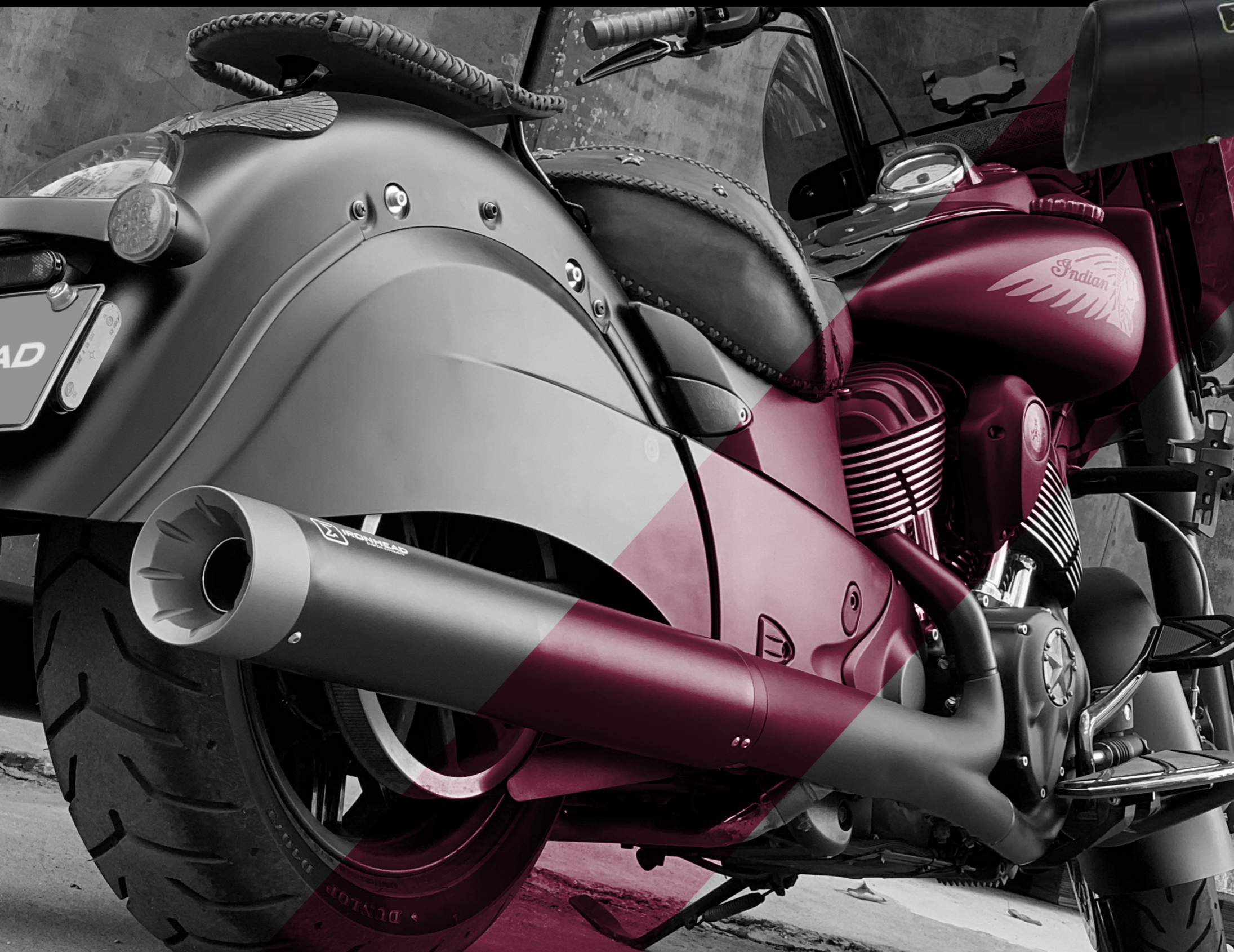

### TECHNICAL DATA

Silenciador fabricado en acero inoxidable AISI 304 con acabado lacado negro y logotipo marcado con Laser.

Tapa de salida adaptable en 4 posiciones, fabricada en acero inoxidable AISI 304 con acabado lacado negro.

Silencer manufactured from AISI 304 stainless Steel with black lacquer finish and Laser print Logo.  
Exit cover adjustable in 4 positions, manufactured from AISI 304 stainless Steel with black lacquer finish.

Schalldampfer aus Edelstahl AISI 304 mit Schwarz lackiert und Laser logo.  
Umfassen sie den Ausgang in vier positionen verstellbar aus Edelstahl AISI 304 mit Schwarz lackiert.

Silencieux fabrique en acier inoxydable AISI 304 avec une finition laquee noire et un marquage du logo a Laser.

Sortie réglables en quatre posotions fabrique en acier inoxydable AISI 304 avec une finition laquee noire.





STREET 750



**HC2B - Ironhead Line**  
HARLEY DAVIDSON

FAT BOB



TOURING ROAD KING



TOURING ROAD KING







**HC2B - Ironhead Line**  
HARLEY DAVIDSON



TOURING STREET GLIDE CVO



TOURING ULTRA LIMITED



TOURING ULTRA LIMITED



TOURING STREET GLIDE CVO





CHIEFTAIN



**HC2B - Ironhead Line**  
INDIAN

DARK HORSE



CHIEFTAIN



SPEEDMASTER









## HC1 - Ironhead Line

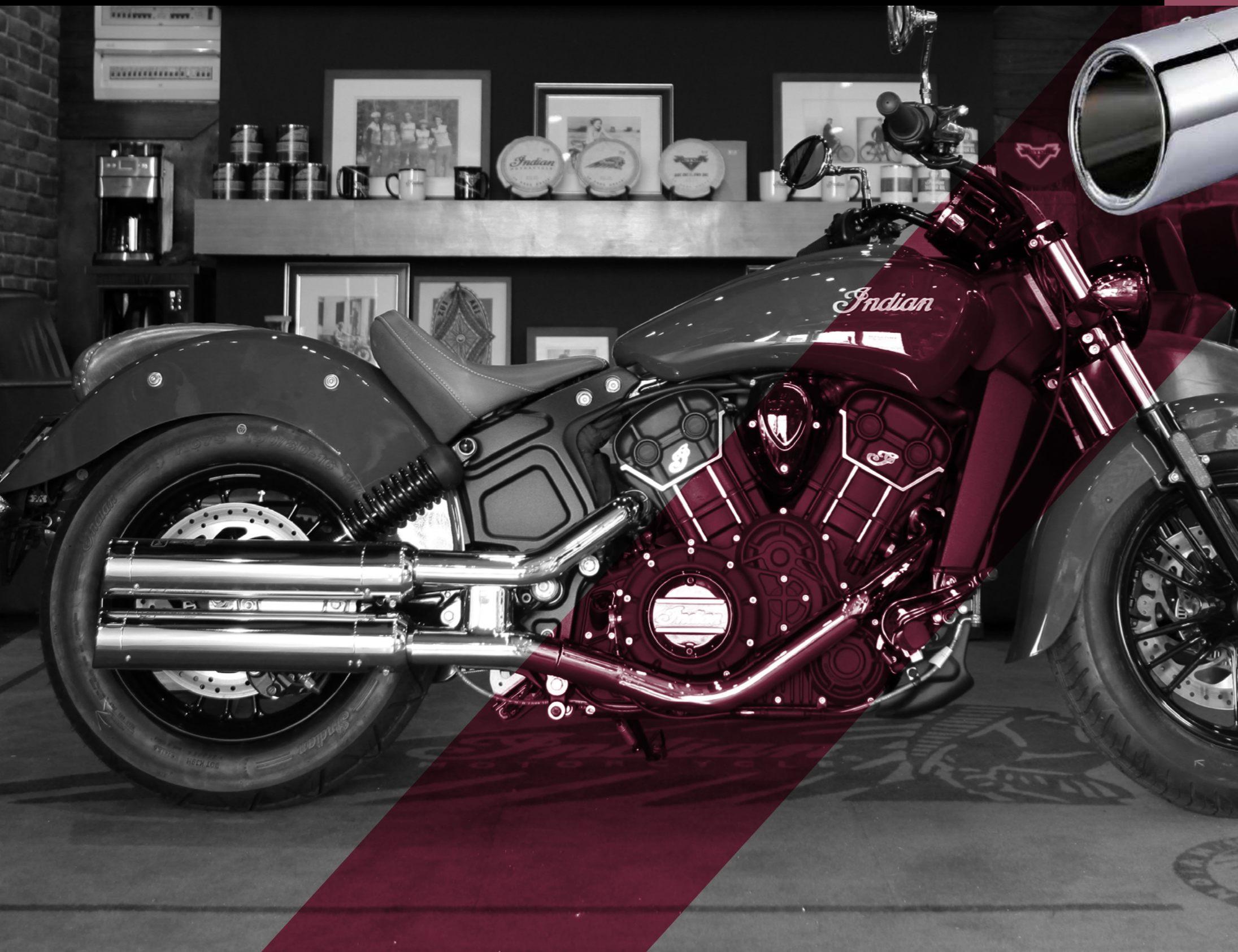

### TECHNICAL DATA

Silenciador fabricado en acero inoxidable AISI 304 con acabado cromado y logotipo marcado con Laser.

Tapa de salida adaptable en 4 posiciones, fabricada en acero inoxidable AISI 304 con acabado cromado.

Silencer manufactured from AISI 304 stainless Steel with chrome finish and Laser print Logo.

Exit cover adjustable in 4 positions, manufactured from AISI 304 stainless Steel with chrome finish.

Schalldämpfer aus Edelstahl AISI 304 mit Chrom und Laser logo.

Umfassen sie den Ausgang in vier positionen verstellbar aus Edelstahl AISI 304 mit Chrom.

Silencieux fabrique en acier inoxydable AISI 304 avec une finition chrome et un marquage du logo a Laser.  
Sortie réglables en quatre posotions fabrique en acier inoxydable AISI 304 avec une finition chrome.





BREAKOUT



**HC1 - Ironhead Line**  
HARLEY DAVIDSON

FAT BOY



DYNA LOW RIDER



SOFTAIL HERITAGE CLASSIC







**HC1 - Ironhead Line**  
HARLEY DAVIDSON



SPORTSTER SEVENTY-TWO



DYNA STREET BOB



FAT BOY

SPORTSTER FORTY-EIGHT





SPORTSTER SEVENTY-TWO



**HC1 - Ironhead Line**  
HARLEY DAVIDSON

SOFTAIL HERITAGE CLASSIC



BREAKOUT



DYNA LOW RIDER







**HC1 - Ironhead Line**  
INDIAN - VICTORY



INDIAN - SCOUT



VICTORY - HIGH BALL



VICTORY - HIGH BALL

INDIAN - SCOUT





HONDA - CB1100RS



**HC1 - Ironhead Line**  
HONDA - TRIUMPH



HONDA - CB1100RS



TRIUMPH - SPEEDMASTER

TRIUMPH - BOBBER









## HC1B - Ironhead Line

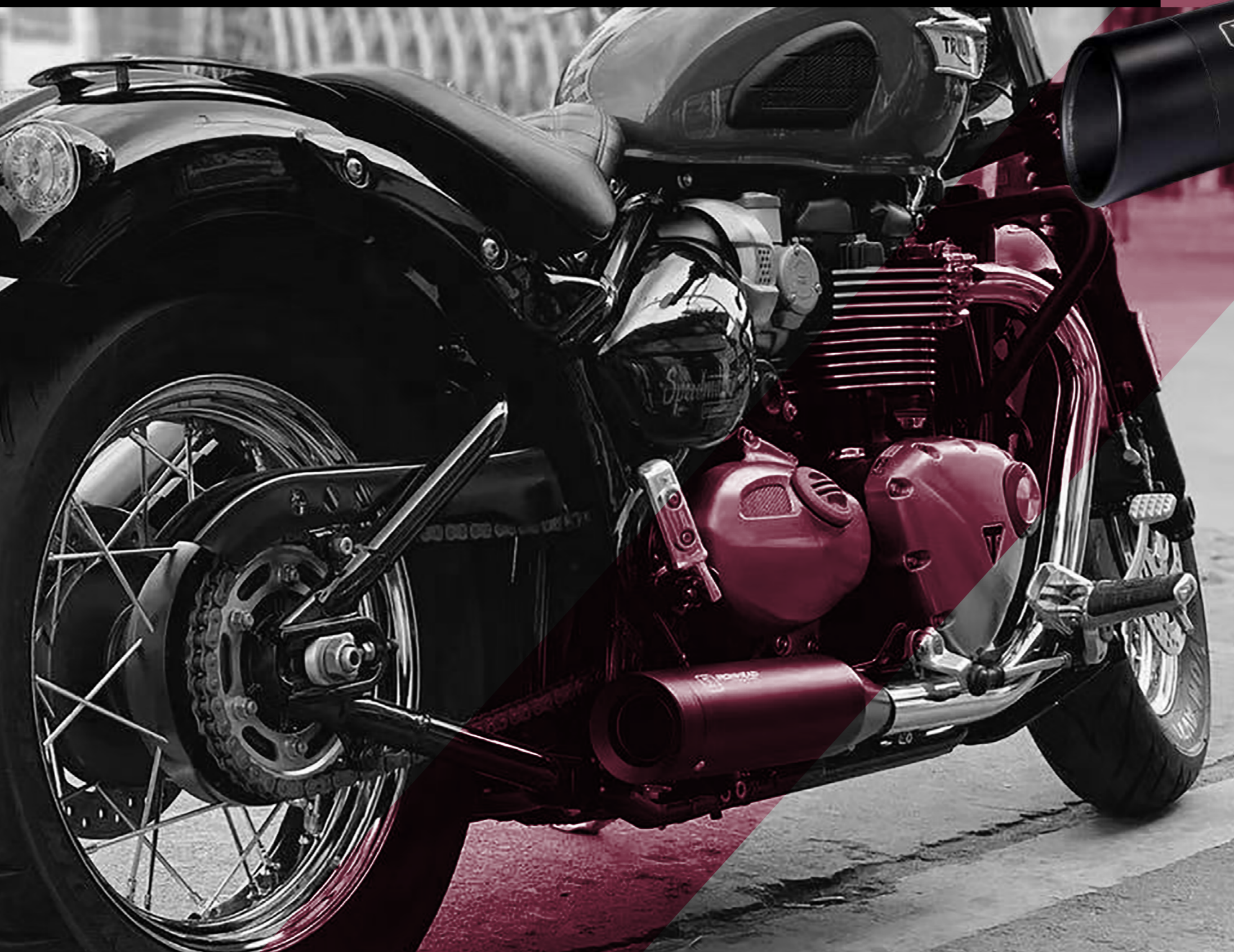

### TECHNICAL DATA

Silenciador fabricado en acero inoxidable AISI 304 con acabado lacado negro y logotipo marcado con Laser.

Tapa de salida adaptable en 4 posiciones, fabricada en acero inoxidable AISI 304 con acabado lacado negro.

Silencer manufactured from AISI 304 stainless Steel with black lacquer finish and Laser print Logo.  
Exit cover adjustable in 4 positions, manufactured from AISI 304 stainless Steel with black lacquer finish.

Schalldämpfer aus Edelstahl AISI 304 mit Schwarz lackiert und Laser logo.  
Umfassen sie den Ausgang in vier positionen verstellbar aus Edelstahl AISI 304 mit Schwarz lackiert.

Silencieux fabrique en acier inoxydable AISI 304 avec une finition laquee noire et un marquage du logo a Laser.

Sortie réglables en quatre posotions fabrique en acier inoxydable AISI 304 avec une finition laquee noire.





BREAKOUT



**HC1B** - Ironhead Line  
HARLEY DAVIDSON

SPORTSTER IRON 883



LOW RIDER



SOFTAIL HERITAGE CLASSIC







**HC1B - Ironhead Line**  
HARLEY DAVIDSON



SPORTSTER SEVENTY-TWO



DYNA STREET BOB



BREAKOUT

SPORTSTER IRON 883





LOW RIDER



**HC1B - Ironhead Line**  
HARLEY DAVIDSON

DYNA STREET BOB



SOFTAIL HERITAGE CLASSIC



SPORTSTER SEVENTY-TWO







**HC1B - Ironhead Line**  
INDIAN - VICTORY



VICTORY - VEGAS



INDIAN - SCOUT SIXTY



VICTORY - JUDGE

VICTORY - HIGH BALL





TRIUMPH - AMERICA



HC1B - Ironhead Line  
TRIUMPH

TRIUMPH - BOBBER



TRIUMPH - SPEEDMASTER 2018

TRIUMPH - SPEEDMASTER









## OVC11 - Ironhead Line

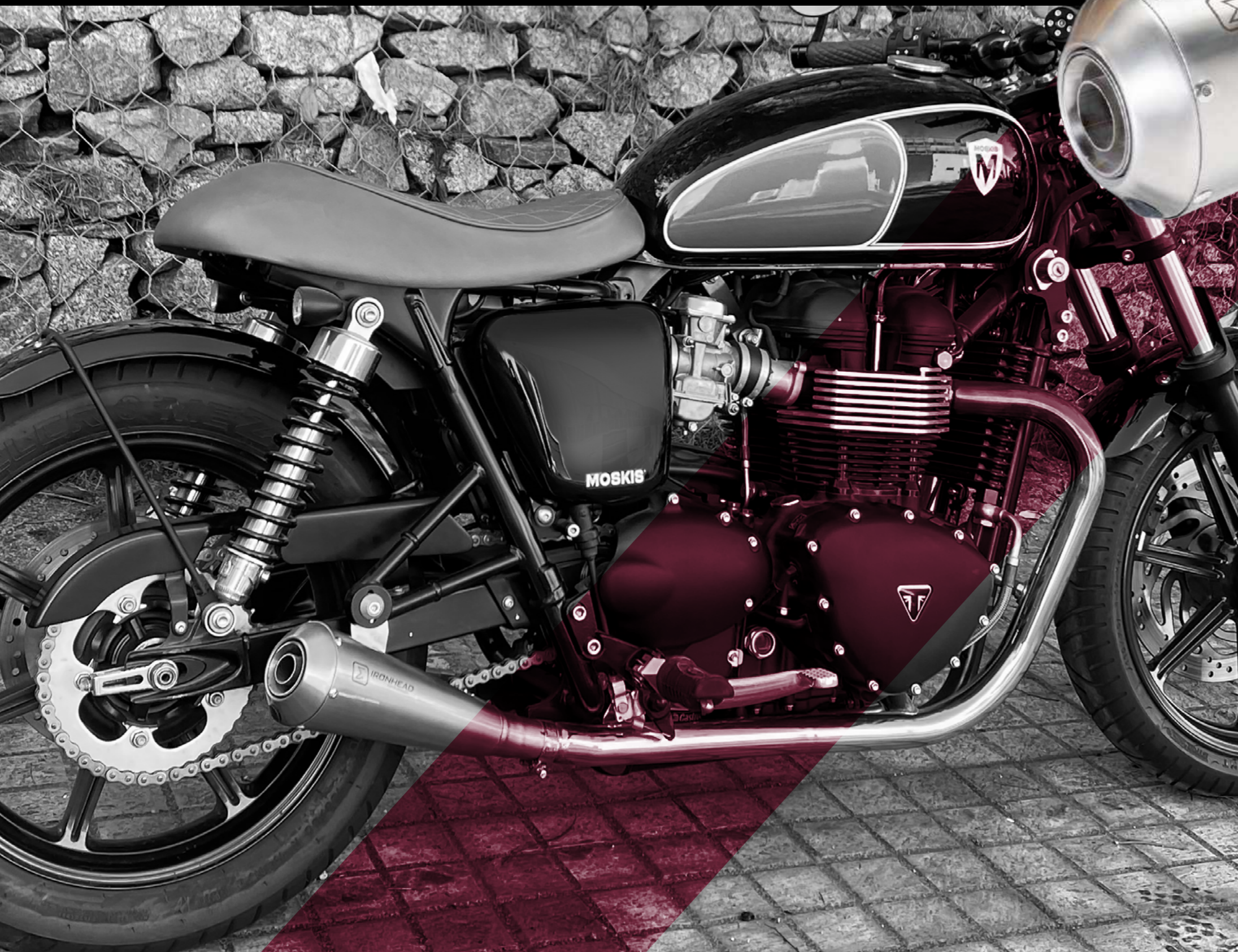

### TECHNICAL DATA

Silenciador fabricado en acero inoxidable AISI 304 con acabado pulido y logotipo marcado con Laser. Tapa de salida fabricada en acero inoxidable AISI 304 con acabado pulido.

Silencer manufactured from AISI 304 stainless Steel polished and Laser print Logo. Exit cap manufactured from AISI 304 stainless Steel polished.

Silencieux fabriqué en acier inoxydable AISI 304 avec une finition satinée et un marquage du logo à Laser. Sortie fabriquée en acier inoxydable AISI 304 avec une finition satinée.

Schalldämpfer aus Edelstahl AISI 304 gebürstet und Laser logo. Ausgang aus Edelstahl AISI 304 gebürstet.





OVC11 - Ironhead Line



MOTO GUZZI - V7 III



MOTO GUZZI - V7 III

TRIUMPH - BONNEVILLE T-100



TRIUMPH - BONNEVILLE T-100



ironhead - OVC11 Line 173







TRIUMPH - STREET TWIN



OVC11 - Ironhead Line

TRIUMPH - BONNEVILLE



TRIUMPH - BONNEVILLE



TRIUMPH - STREET TWIN





OVC11 - Ironhead Line

TRIUMPH - THRUXTON 1200 R



TRIUMPH - THRUXTON 900



TRIUMPH - THRUXTON 900



TRIUMPH - THRUXTON 1200 R





TRIUMPH - BONNEVILLE T120



TRIUMPH - BONNEVILLE T120



TRIUMPH - T120 BLACK



OVC11 - Ironhead Line  
TRIUMPH



TRIUMPH - T120 BLACK









## OVC13 - Ironhead Line

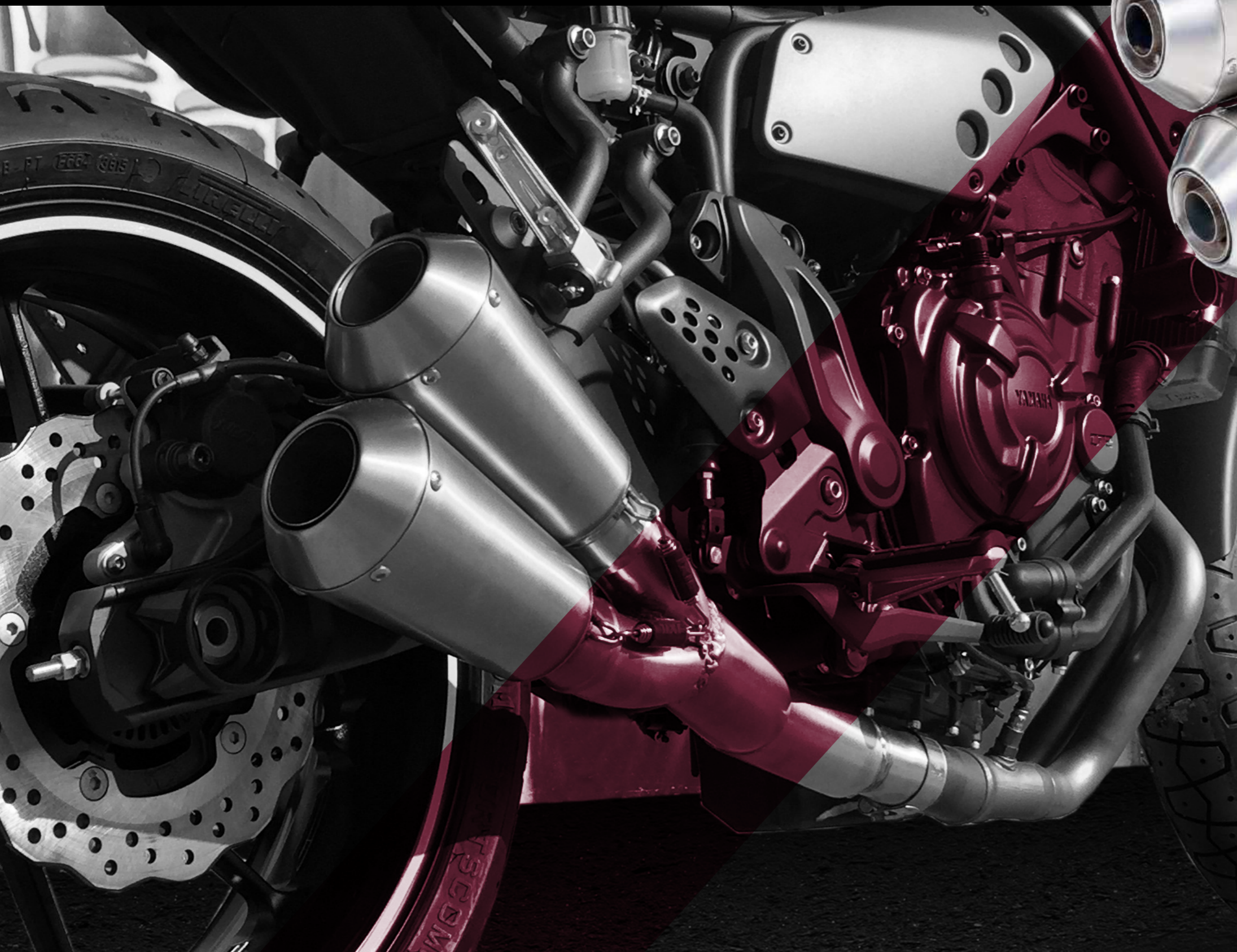

### TECHNICAL DATA

Silenciador fabricado en acero inoxidable AISI 304 con acabado pulido y logotipo marcado con Laser. Tapa de salida fabricada en acero inoxidable AISI 304 con acabado pulido.

Silencer manufactured from AISI 304 stainless Steel polished and Laser print Logo. Exit cap manufactured from AISI 304 stainless Steel polished.

Silencieux fabrique en acier inoxydable AISI 304 avec une finition satinée et un marquage du logo a Laser. Sortie fabrique en acier inoxydable AISI 304 avec une finition satinée.

Schalldampfer aus Edelstahl AISI 304 geburstet und Laser logo. Ausgang aus Edelstahl AISI 304 geburstet.







OVC13 - Ironhead Line

BMW - NINET



KAWASAKI - W800



KAWASAKI - W800



BMW - NINET







YAMAHA - XSR700



OVC13 - Ironhead Line  
TRIUMPH



YAMAHA - XSR700



YAMAHA - XSR900

YAMAHA - XSR900













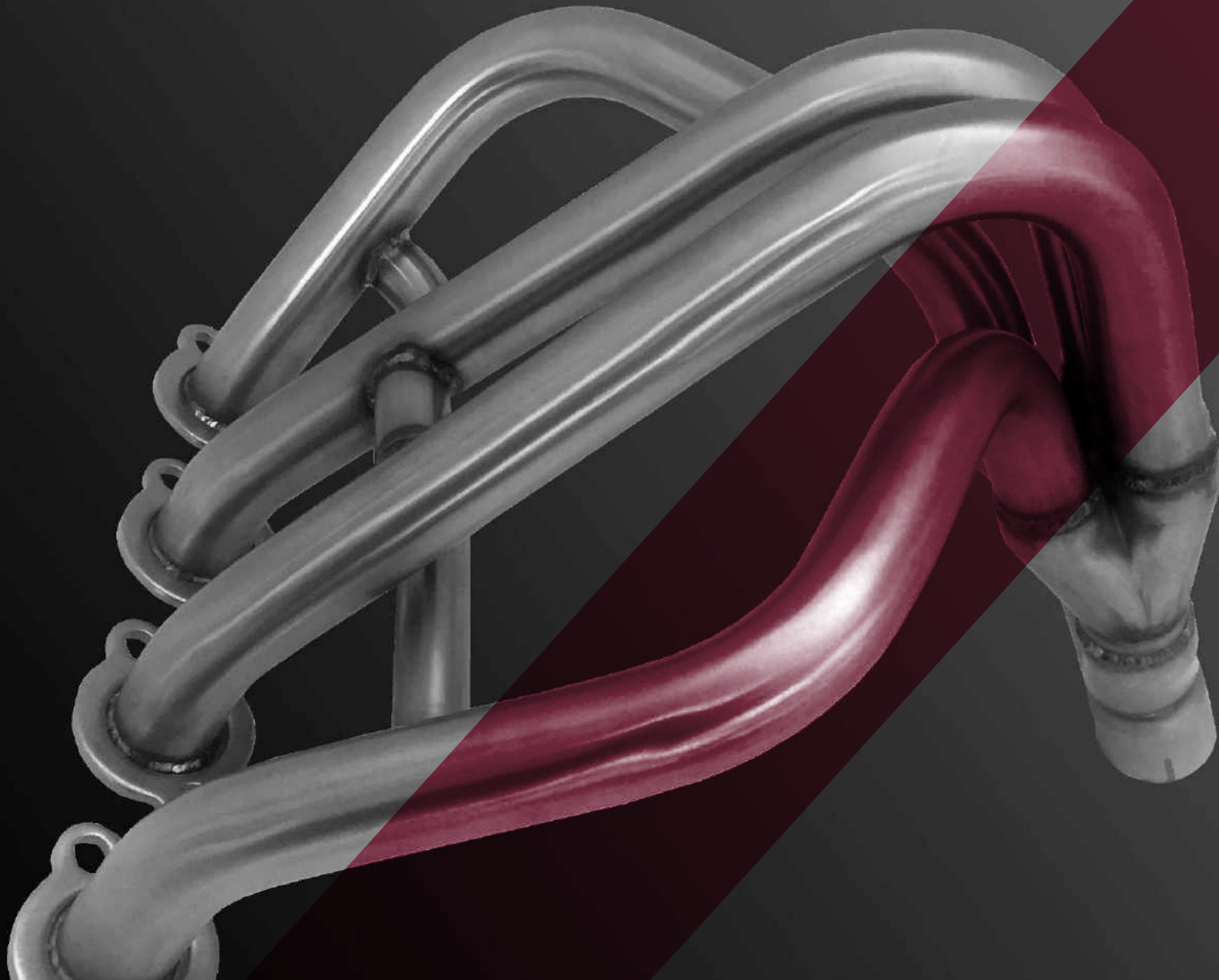

#### TECHNICAL DATA

Supresor de catalizador fabricado en acero inoxidable AISI304 con acabado satinado mate. Este producto ha sido diseñado para uso exclusivo en circuitos cerrados, no homologado para su utilización en vía pública.

Suppressor of catalyst manufactured from AISI304 stainless steel with a satin polished finish. This product has been designed for an exclusive use in closed circuits.

Suppresseur de catalyseur fabriqué en acier inoxydable AISI304. Finition satiné mate. Ce produit est dédié à utilisation exclusive en circuit fermé et n'est pas homologué pour une utilisation sur la voie publique.

Ersatzrohr für den Katalysator hergestellt aus rostfreiem AISI304 stahl mit seidenmatt polierter oberfläche. Dieses Produkt wurde exklusiv für die Nutzung auf geschlossenen Rennstrecken entwickelt.





**DKAT - Parts**  
Catalyst Suppressor

HONDA - CB650F



HONDA - CB1000R



HONDA - CB1000R HORNET



HONDA - CBR500R





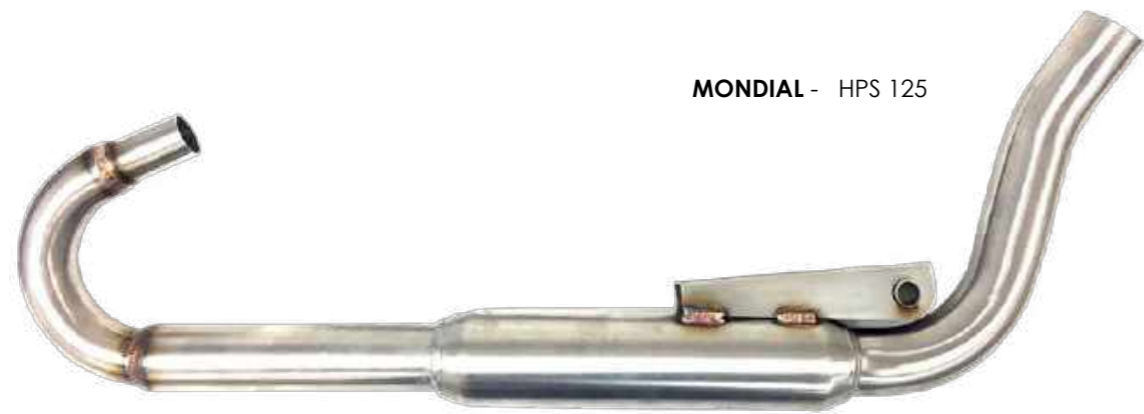

MONDIAL - HPS 125



KTM - DUKE 125-390

**DKAT - Parts**  
Catalyst Suppressor



KTM - SUPERDUKE 1290

INDIAN - FTR1200



KAWASAKI - Z900RS



KAWASAKI - Z900





**IXIL**  
design





# WATERPROOF BAGS - Design

Travel Solutions







**BG013BK**  
Waterproof bag, 30 lts.



**Reference** BG013BK  
**Material** TPU  
**Color** Black  
**Capacity** 30 lts.  
**Sizes** 525 mm. (wide)  
 300 mm. (deep)  
 235 mm. (height)  
**EAN code** 8435467523878

**TECHNICAL DATA**

Bolsa impermeable para uso deportivo o recreacional. Incluye 2 asas a cada lado para fijar a la motocicleta, barco u otros, y tiras reflectantes para mayor seguridad. En el lado derecho hay una válvula de ventilación.

Waterproof carry on bag for sport or leisure use. Include 2 hangers at each side to fix on the motorcycle, boat or others and reflective strips on both sides for more security. On left side there's an air valve to inflate or remove the air.





**OXOL**  
RACING PERFORMANCE PARTS



Wanderlich

Wanderlich





**BG015BK**  
Waterproof bag, 50 lts.



<b>Reference</b>	BG015BK
<b>Material</b>	TPU
<b>Color</b>	Black
<b>Capacity</b>	50 lts.
<b>Sizes</b>	620 mm. (wide) 350 mm. (deep) 265 mm. (height)
<b>EAN code</b>	8435467523885

**TECHNICAL DATA**

Bolsa impermeable para uso deportivo o recreacional. Incluye 2 asas a cada lado para fijar a la motocicleta, barco u otros, y tiras reflectantes para mayor seguridad. En el lado derecho hay una válvula de ventilación.

Waterproof carry on bag for sport or leisure use. Include 2 hangers at each side to fix on the motorcycle, boat or others and reflective strips on both sides for more security. On left side there's an air valve to inflate or remove the air.









**BG016BK**  
Waterproof XL bag, 65 lts.



**Reference** BG016BK  
**Material** TPU  
**Color** Black  
**Capacity** 65 lts.  
**Sizes** 750 mm. (wide)  
 330 mm. (deep)  
 330 mm. (height)  
**EAN code** 8435467523892

**TECHNICAL DATA**

Bolsa impermeable para uso deportivo o recreacional. Incluye 2 asas a cada lado para fijar a la motocicleta, barco u otros, y tiras reflectantes para mayor seguridad. En la parte superior hay una válvula de ventilación e incluye un bolsillo lateral impermeable con cremallera.

Waterproof carry on bag for sport or leisure use. Include 2 hangers at each side to fix on the motorcycle, boat or others and reflective strips for more security. On top there's an air valve to inflate or remove the air, Include a waterproof zipped pocket.









**BG021BK**  
Waterproof backpack, 35 lts.



**Reference** BG021BK  
**Material** TPU  
**Color** Black  
**Capacity** 35 lts.  
**Sizes** 320 mm. (wide)  
240 mm. (deep)  
525 mm. (height)  
**EAN code** 8435467523861

**TECHNICAL DATA**

Bolsa impermeable para uso deportivo o recreacional. Incluye 2 asas a cada lado para fijar a la motocicleta, barco u otros, y tiras reflectantes para mayor seguridad. En el lado derecho hay una válvula de ventilación.

Waterproof carry on bag for sport or leisure use. Include 2 hangers at each side to fix on the motorcycle, boat or others and reflective strips on both sides for more security. On left side there's an air valve to inflate or remove the air.









**BG022BK**  
Waterproof backpack, 22 lts.



**Reference** BG022BK  
**Material** TPU  
**Color** Black  
**Capacity** 22 lts.  
**Sizes** 280 mm. (wide)  
220 mm. (deep)  
490 mm. (height)  
**EAN code** 8435467525391

**TECHNICAL DATA**

Mochila impermeable para uso deportivo o recreacional con cremallera estanca. Incluye una tira elástica lateral y un tira reforzada inferior con argolla de aluminio para una correcta fijación. Nuevo logotipo IXIL Design con propiedades reflectantes para mayor seguridad. En el lado izquierdo hay una válvula de ventilación para extraer el aire del interior.

Waterproof backpack for sport or leisure use with waterproof zipper. Include one elastic strip at each side and a reinforced lower strip with aluminium hanger for proper fixation. New 2020 IXIL Design logo with reflective properties for more security. On left side there's an air valve to inflate or remove the air.









**BG022GY**  
Waterproof backpack, 22 lts.



**Reference** BG022GY  
**Material** TPU  
**Color** Grey  
**Capacity** 22 lts.  
**Sizes** 280 mm. (wide)  
 220 mm. (deep)  
 490 mm. (height)  
**EAN code** 8435467525407

**TECHNICAL DATA**

Mochila impermeable para uso deportivo o recreacional con cremallera estanca. Incluye una tira elástica lateral y una tira reforzada inferior con argolla de aluminio para una correcta fijación. Nuevo logotipo IXIL Design con propiedades reflectantes para mayor seguridad. En el lado izquierdo hay una válvula de ventilación para extraer el aire del interior.

Waterproof backpack for sport or leisure use with waterproof zipper. Include one elastic strip at each side and a reinforced lower strip with aluminium hanger for proper fixation. New 2020 IXIL Design logo with reflective properties for more security. On left side there's an air valve to inflate or remove the air.





















# **IXIL**

applications

























REFERENCE	RANGE	EXHAUST TYPE	CE	INSIDE
<b>APRILIA</b>				
<b>AMICO 50</b>				
 YAM 2334	SCCL	FULL SYSTEM	NO	NO
<b>RALLY 50</b>				
 YAM 2326	SCCL	FULL SYSTEM	NO	NO
<b>SCARABEO 50</b>				
 YAM 2326	SCCL	FULL SYSTEM	NO	NO
<b>SONIC 50 AIR/L.C.</b>				
 YAM 2326	SCCL	FULL SYSTEM	NO	NO
<b>SR 50 92-93</b>				
 YAM 2334	SCCL	FULL SYSTEM	NO	NO
<b>SR 50 00&gt; AIR/L.C. (RL)</b>				
 SZ 2822	SCCL	FULL SYSTEM	YES	NO
<b>SR 50 WWW 94-99 AIR/L.C.</b>				
 YAM 2326	SCCL	FULL SYSTEM	NO	NO
<b>CR 125 / 150</b>				
 KIT 019 C1	DKAT	DKAT - FULL COLECTOR	NO	NO
 OA 619 RR	RC1	SLIP ON	NO	TP-OVC12
 XA 0319 V	L2X	SLIP ON	NO	NO
<b>RSV V4 1100</b>				
 CA 3285 RC	RC	SLIP ON	NO	NO
 OA 3085 VTR	VTI	SLIP ON	NO	NO
<b>TUONO V4 1100</b>				
 CA 3285 RC	RC	SLIP ON	NO	NO
 OA 3085 VTR	VTI	SLIP ON	NO	NO
<b>ATALA</b>				
<b>CAROSSELLO 50</b>				
 YAM 2326	SCCL	FULL SYSTEM	NO	NO
<b>BENELLI</b>				
<b>491 STRADA/GT/SP 50 AIR/L.C. - MINARELLI HORIZONTAL</b>				
 YAM 2326	SCCL	FULL SYSTEM	NO	NO
<b>K2 NAMUR 50 AIR/L.C. - MINARELLI HORIZONTAL</b>				
 YAM 2326	SCCL	FULL SYSTEM	NO	NO
<b>TNT 125 / T 125</b>				
 OB 506 SS	RCS	SLIP ON	NO	TP.OV3
 XB 5306 V	L2X	SLIP ON	NO	NO











REFERENCE	RANGE	EXHAUST TYPE	CE	INSIDE
<b>LEONCINO 250</b>				
 OB 501 RR	RC1	FULL SYSTEM	NO	TP-OVC12
<b>TNT 250 / BN 251</b>				
 XB 5305 XB	L3XB	SLIP ON	NO	TP-HP4
<b>BJ 300 GS / BN 302</b>				
 XB 5303 XB	L3XB	SLIP ON	NO	TP-HP4
<b>BJ 300 GS-C / BN 302 R</b>				
 XB 5309 XB	L3XB	SLIP ON	NO	TP-HP4
<b>LEONCINO 500</b>				
 OB 551 RR	RC1	SLIP ON	NO	TP-OVC12
<b>TRK 502 16-19</b>				
 OB 535 RR	RC1	SLIP ON	NO	TP-OVC12
<b>BN 502 C '19</b>				
 OB 553 RR	RC1	SLIP ON	NO	TP-OVC12
<b>BN 752 S '19</b>				
 OB 552 RR	RC1	SLIP ON	NO	TP-OVC12
<b>BN 600 13 -14</b>				
 FB 5840 SS	X55S	DUAL SLIP ON (RIGHT AND LEFT SIDE)	NO	TP-X55SS
<b>BETA</b>				
<b>ARK 50 - MINARELLI HORIZONTAL</b>				
 YAM 2326	SCCL	FULL SYSTEM	NO	NO
<b>CHRONO 50 - MINARELLI HORIZONTAL</b>				
 YAM 2326	SCCL	FULL SYSTEM	NO	NO
<b>QUADRA 50 - MINARELLI HORIZONTAL</b>				
 YAM 2326	SCCL	FULL SYSTEM	NO	NO
<b>TEMPO 50 - MINARELLI HORIZONTAL</b>				
 YAM 2326	SCCL	FULL SYSTEM	NO	NO
<b>BMW</b>				
<b>G 310 R 18-19</b>				
 OB 5029 VSE	SOVE	FULL SYSTEM	NO	TP-OV70
<b>C 600 SPORT 12-14</b>				
 OB 5091 VSE	SOVE	SLIP ON	NO	TP-OV70
<b>C 650 SPORT 16-19</b>				
 XB 5579 XS	L5X	SLIP ON	NO	NO
<b>G 650 X-COUNTRY 07-09 (EGSX)</b>				
 OB 5090 VSE	SOVE	SLIP ON	NO	TP-OV70
<b>G 650 X-CHALLENGE 07-09 (EGSX)</b>				
 OB 5090 VSE	SOVE	SLIP ON	NO	TP-OV70











REFERENCE	RANGE	EXHAUST TYPE	CE	INSIDE
<b>G 650 X-MOTO 07-09 (EGSX)</b>				
 OB 5090 VSE	SOVE	SLIP ON	NO	TP-OV70
<b>F 650 GS 09-13 (E8GS)</b>				
 OB 5094 VSE	SOVE	SLIP ON	YES	TP-OV70
<b>F 800 S 06-09</b>				
 OB 5092 VSE	SOVE	SLIP ON	NO	TP-OV70
<b>F 800 ST 06-09</b>				
 OB 5092 VSE	SOVE	SLIP ON	NO	TP-OV70
<b>F 800 R 09-15 (E8ST)</b>				
 OB 5094 VSE	SOVE	SLIP ON	YES	TP-OV70
<b>F 800 GS 09-15 (E8GS)</b>				
 OB 5094 VSE	SOVE	SLIP ON	YES	TP-OV70
<b>S 1000 XR 15-19</b>				
 OB 593 RR	RC1	SLIP ON	NO	TP-OVC12
<b>NINET</b>				
 HB 5080 SB	HC1-3B	SLIP ON	NO	TP-OV3
 OB 580 SS	OVC13	SLIP ON	NO	TP-OV3
<b>R 1200 GS ADVENTURE 06-09</b>				
 OB 5098 VSE	SOVE	SLIP ON	NO	TP-OV70
<b>R 1200 GS 13-15 (R12W)</b>				
 OB 5097 VSE	SOVE	SLIP ON	YES	TP-OV70
<b>R 1200 GS 16-17</b>				
 EB 5095 SS	MXT	SLIP ON	YES	TP-MXT80
<b>R 1250 GS 18-19</b>				
 EB 5095 SS	MXT	SLIP ON	YES	TP-MXT80
<b>CFMOTO</b>				
<b>NK 250</b>				
 OF 325 RRB	RC1B	FULL SYSTEM	NO	TP-OVC12S
<b>GT 400</b>				
 CF 3233 RC	RC	SLIP ON	NO	TP-OVC12
<b>NK 400</b>				
 CF 3230 RC	RC	SLIP ON	NO	TP-OVC12
<b>GT 650</b>				
 CF 3233 RC	RC	SLIP ON	NO	TP-OVC12
<b>NK 650</b>				
 CF 3230 RC	RC	SLIP ON	NO	TP-OVC12
<b>MT 650</b>				
 OF 331 RRB	RC1B	SLIP ON	NO	TP-OVC12

REFERENCE	RANGE	EXHAUST TYPE	CE	INSIDE
<b>CPI</b>				
<b>CPI EURO II '04</b>				
 C 392	SCCL	FULL SYSTEM	YES	NO
<b>DAELIM</b>				
<b>MESSAGE</b>				
 K 301	SCCL	FULL SYSTEM	NO	NO
<b>ROADWIN 125 (VJ125)</b>				
 OD 5011 VSE	SOVE	BOLT ON	NO	TP-OV70
 OD 5011 VSEB	XOVE	BOLT ON	NO	TP-OV70
<b>ROADWIN 125 R 07-15 (BA8)</b>				
 OD 5012 VSE	SOVE	BOLT ON	YES	TP-OV70
 OD 5012 VSEB	XOVE	BOLT ON	YES	TP-OV70
<b>ROADSPORT 125 R 07-15 (BA8)</b>				
 OD 5012 VSE	SOVE	BOLT ON	YES	TP-OV70
 OD 5012 VSEB	XOVE	BOLT ON	YES	TP-OV70
<b>ROADWIN 250 R 12-15</b>				
 OD 5012 VSE	SOVE	BOLT ON	NO	TP-OV70
 OD 5012 VSEB	XOVE	BOLT ON	NO	TP-OV70
<b>DERBI</b>				
<b>EASY - MINARELLI HORIZONTAL</b>				
 YAM 2326	SCCL	FULL SYSTEM	NO	NO
<b>VAMOS 50 - FRANCO MORINI</b>				
 SZ 2820	SCCL	FULL SYSTEM	NO	NO
<b>TERRA 125 ADVENTURE 10-12 (TS)</b>				
 OD 3307 VSE	SOVE	SLIP ON	YES	TP-OV70
 OD 3307 VSEB	XOVE	SLIP ON	YES	TP-OV70
<b>DRD 125 4T 10-12</b>				
 OD 3307 VSE	SOVE	SLIP ON	NO	TP-OV70
 OD 3307 VSEB	XOVE	SLIP ON	NO	TP-OV70
<b>DUCATI</b>				
<b>SCRAMBLER 400</b>				
 OD 549 RRB	RC1B	SLIP ON	NO	TP-OVC12
<b>M 696 MONSTER 08-13</b>				
 FD 5844 SS	X55S	SLIP ON (RIGHT MUFFLER)	NO	TP-X55SS
 FD 5845 SS	X55S	SLIP ON (LEFT MUFFLER)	NO	TP-X55SS
<b>750 SS '98 (V2 750 SS)</b>				
 OD 5062 VSE	SOVE	SLIP ON (RIGHT MUFFLER)	YES	TP-OV70



























	REFERENCE	RANGE	EXHAUST TYPE	CE	INSIDE
	OD 5063 VSE	SOVE	SLIP ON (LEFT MUFFLER)	YES	TP-OV70
<b>SCRAMBLER 800</b>					
	OD 550 RRB	RC1B	SLIP ON	NO	TP-OVC12
<b>M 821 MONSTER</b>					
	FD 5848 S2	X55SP	SLIP ON	NO	TP-X55SS
<b>848 2008-2010</b>					
	OD 5084 VSE	SOVE	SLIP ON (RIGHT MUFFLER)	NO	TP-OV70
	OD 5085 VSE	SOVE	SLIP ON (LEFT MUFFLER)	NO	TP-OV70
<b>939 SUPERSPORT 17-19</b>					
	SD 5110 C	SX1	SLIP ON	NO	TP-OV6
<b>1098 2007-2010</b>					
	OD 5084 VSE	SOVE	SLIP ON (RIGHT MUFFLER)	NO	TP-OV70
	OD 5085 VSE	SOVE	SLIP ON (LEFT MUFFLER)	NO	TP-OV70
<b>1198 2008-2010</b>					
	OD 5084 VSE	SOVE	SLIP ON (RIGHT MUFFLER)	NO	TP-OV70
	OD 5085 VSE	SOVE	SLIP ON (LEFT MUFFLER)	NO	TP-OV70

**GILERA**

<b>DNA 50</b>					
	V 280	SCCL	FULL SYSTEM	NO	NO
<b>EASY MOVING 50</b>					
	V 280	SCCL	FULL SYSTEM	NO	NO
<b>RUNNER 50</b>					
	V 280	SCCL	FULL SYSTEM	NO	NO
<b>SRK 50</b>					
	V 280	SCCL	FULL SYSTEM	NO	NO
<b>STALKER 50</b>					
	V 280	SCCL	FULL SYSTEM	NO	NO
<b>STORM 50</b>					
	V 280	SCCL	FULL SYSTEM	NO	NO
<b>GP 800 07-15</b>					
	OG 0528 VSE	SOVE	BOLT ON	NO	TP-OV70
	OG 0528 VSEB	XOVE	BOLT ON	NO	TP-OV70

**HARLEY DAVIDSON**

<b>STREET 500 2014-2016</b>					
	HD 1001 SB	HC2-2B	SLIP ON	NO	TP-OV3
	HD 1001 SC	HC2-2C	SLIP ON	NO	TP-OV3

	HD 1002 SC	HC2-3C	SLIP ON	NO	TP-OV3
<b>STREET 750 2014-2016</b>					
	HD 1001 SB	HC2-2B	SLIP ON	NO	TP-OV3
	HD 1001 SC	HC2-2C	SLIP ON	NO	TP-OV3
	HD 1002 SC	HC2-3C	SLIP ON	NO	TP-OV3
<b>SPORTSTER XL 883 2004-2013</b>					
	HD 1008 SB	HC1-3B	SLIP ON (UPPER MUFFLER)	YES	TP-OV3
	HD 1008 SB	HC1-3B	SLIP ON (LOWER MUFFLER)	YES	TP-OV3
	HD 1008 SC	HC1-3C	SLIP ON (UPPER MUFFLER)	YES	TP-OV3
	HD 1008 SC	HC1-3C	SLIP ON (LOWER MUFFLER)	YES	TP-OV3
<b>SPORTSTER XL 883 2014-2016</b>					
	HD 1009 SB	HC1-3B	SLIP ON (LOWER MUFFLER)	YES	TP-OV3
	HD 1009 SB	HC1-3B	SLIP ON (UPPER MUFFLER)	YES	TP-OV3
	HD 1009 SC	HC1-3C	SLIP ON (LOWER MUFFLER)	YES	TP-OV3
	HD 1009 SC	HC1-3C	SLIP ON (UPPER MUFFLER)	YES	TP-OV3
<b>SPORTSTER XL 1200 2004-2013</b>					
	HD 1008 SB	HC1-3B	SLIP ON (UPPER MUFFLER)	YES	TP-OV3
	HD 1008 SB	HC1-3B	SLIP ON (LOWER MUFFLER)	YES	TP-OV3
	HD 1008 SC	HC1-3C	SLIP ON (UPPER MUFFLER)	YES	TP-OV3
	HD 1008 SC	HC1-3C	SLIP ON (LOWER MUFFLER)	YES	TP-OV3
<b>SPORTSTER XL 1200 2014-2016</b>					
	HD 1009 SB	HC1-3B	SLIP ON (LOWER MUFFLER)	YES	TP-OV3
	HD 1009 SB	HC1-3B	SLIP ON (UPPER MUFFLER)	YES	TP-OV3
	HD 1009 SC	HC1-3C	SLIP ON (UPPER MUFFLER)	YES	TP-OV3
	HD 1009 SC	HC1-3C	SLIP ON (LOWER MUFFLER)	YES	TP-OV3
<b>DYNA STREET BOB 2006-2016</b>					
	HD 1006 SB	HC1-3B	SLIP ON (UPPER MUFFLER)	NO	TP-OV3
	HD 1006 SB	HC1-3B	SLIP ON (LOWER MUFFLER)	NO	TP-OV3
	HD 1006 SC	HC1-3C	SLIP ON (UPPER MUFFLER)	NO	TP-OV3
	HD 1006 SC	HC1-3C	SLIP ON (LOWER MUFFLER)	NO	TP-OV3
<b>DYNA LOW RIDER 2014-2016</b>					
	HD 1003 SB	HC1-2B	SLIP ON	NO	TP-OV3





REFERENCE	RANGE	EXHAUST TYPE	CE	INSIDE
<b>FAT BOB 18-19</b>				
 HD 1020 SB	HC2-2B	SLIP ON (UPPER MUFFLER)	NO	TP-OV3
 HD 1020 SB	HC2-2C	SLIP ON (LOWER MUFFLER)	NO	TP-OV3
<b>SOFTAIL FAT BOY 2006-2016</b>				
 HD 1007 SB	HC1-3B	SLIP ON (UPPER MUFFLER)	NO	TP-OV3
 HD 1007 SB	HC1-3B	SLIP ON (LOWER MUFFLER)	NO	TP-OV3
 HD 1007 SC	HC1-3C	SLIP ON (UPPER MUFFLER)	NO	TP-OV3
 HD 1007 SC	HC1-3C	SLIP ON (LOWER MUFFLER)	NO	TP-OV3
<b>SOFTAIL FAT BOY 2019</b>				
 HD 1022 SS	HC1-3S	SLIP ON (UPPER MUFFLER)	NO	TP-OV3
 HD 1023 SS	HC1-3S	SLIP ON (LOWER MUFFLER)	NO	TP-OV3
<b>SOFTAIL BREAKOUT 2013-2016</b>				
 HD 1005 SB	HC1-3B	SLIP ON (UPPER MUFFLER)	NO	TP-OV3
 HD 1005 SB	HC1-3B	SLIP ON (LOWER MUFFLER)	NO	TP-OV3
<b>SOFTAIL DELUXE 2007-2016</b>				
 HD 1004 ASC	HC1-3C	SLIP ON (UPPER MUFFLER)	NO	TP-OV3
 HD 1004 BSC	HC1-3C	SLIP ON (LOWER MUFFLER)	NO	TP-OV3
<b>SOFTAIL SLIM 2012-2016</b>				
 HD 1004 ASC	HC1-3C	SLIP ON (UPPER MUFFLER)	NO	TP-OV3
 HD 1004 BSC	HC1-3C	SLIP ON (LOWER MUFFLER)	NO	TP-OV3
<b>TOURING ROAD KING 2006-2016</b>				
 HD 1016 SB	HC2-1B	SLIP ON (RIGHT MUFFLER)	YES	TP-OV3
 HD 1016 SC	HC2-1C	SLIP ON (RIGHT MUFFLER)	YES	TP-OV3
 HD 1017 SB	HC2-1B	SLIP ON (LEFT MUFFLER)	YES	TP-OV3
 HD 1017 SC	HC2-1C	SLIP ON (LEFT MUFFLER)	YES	TP-OV3
<b>TOURING ROAD KING 2017</b>				
 HD 1018 SB	HC2-1B	SLIP ON (RIGHT MUFFLER)	NO	TP-OV3
 HD 1018 SC	HC2-1C	SLIP ON (RIGHT MUFFLER)	NO	TP-OV3
 HD 1019 SB	HC2-1B	SLIP ON (LEFT MUFFLER)	NO	TP-OV3
 HD 1019 SC	HC2-1C	SLIP ON (LEFT MUFFLER)	NO	TP-OV3



























**HONDA**

<b>SFX 50</b>				
 H 1955	SCCL	FULL SYSTEM	YES	NO























REFERENCE	RANGE	EXHAUST TYPE	CE	INSIDE
<b>BALI 50</b>				
 H 1955	SCCL	FULL SYSTEM	NO	NO
<b>DIO 50</b>				
 K 301	SCCL	FULL SYSTEM	NO	NO
<b>VISION 50</b>				
 HP 1951	SCCL	FULL SYSTEM	NO	NO
<b>VISION 75</b>				
 H 1950	SCCL	BOLT ON	NO	NO
<b>MSX 125 / GROOM 13-19</b>				
 OH 615 SB	RCSB	FULL SYSTEM	NO	TP-OV3
 XH 6315 V	L2X	FULL SYSTEM	NO	NO
<b>MONKEY 125 18-19</b>				
 OH 612 SS	RCS	FULL SYSTEM	NO	TP-OV3
 XH 6312 V	L2X	FULL SYSTEM	NO	NO
<b>CBF 125 09-15 (JC40)</b>				
 OH 6016 VSE	SOVE	FULL SYSTEM	NO	TP-OV70
<b>XL 125 V VARADERO 04-15 (JC32)</b>				
 OH 6011 VSE	SOVE	SLIP ON	YES	TP-OV70
<b>CBR 125 R 04-10 (JC34,JC39)</b>				
 OH 6013 VSE	SOVE	SLIP ON	NO	TP-OV70
<b>CBR 125 R 11-15</b>				
 OH 6018 VSE	SOVE	SLIP ON	NO	TP-OV70
 XH 6318 V	L2X	SLIP ON	NO	NO
<b>CB 125 R '18 (JC79)</b>				
 OH 608 RRB	RC1B	FULL SYSTEM	YES	TP-OVC12
<b>CBR 250 R 11-14</b>				
 OH 6019 VSE	SOVE	FULL SYSTEM	NO	TP-OV70
 OH 6219 VSE	SOVE	SLIP ON	NO	TP-OV70
 XH 6319 XB	L3XB	SLIP ON	NO	TP-HP4
<b>VTR 250 '98 CARBURATOR</b>				
 OH 6017 VSE	SOVE	FULL SYSTEM	NO	TP-OV70
<b>VTR 250i 10-14</b>				
 OH 6020 VSE	SOVE	FULL SYSTEM	NO	TP-OV70
 OH 6020 VSEB	XOVE	FULL SYSTEM	NO	TP-OV70
<b>CBR 300 R 15-17</b>				
 OH 6127 VSE	SOVE	FULL SYSTEM	NO	TP-OV70





























	REFERENCE	RANGE	EXHAUST TYPE	CE	INSIDE
	OH 6219 VSE	SOVE	SLIP ON	NO	TP-OV70
	XH 6327 XB	L3XB	SLIP ON	NO	TP-HP4
<b>CB 300 R 18-19</b>					
	OH 630 RR	RC1	SLIP ON	NO	TP-OVC12
	OH 630 RRB	RC1B	SLIP ON	NO	TP-OVC12
	XH 6230 XN	L3N	SLIP ON	NO	TP-HP2
<b>CB 400 EFI 08-12</b>					
	OH 6026 VSE	SOVE	SLIP ON	NO	TP-OV70
<b>TRX 400 EX SPORTRAX 99-04</b>					
	AH 6425 EV	SOVE	QRACE OVAL INOX - SILENCER	NO	TP-OV70
<b>REBEL CMX 500</b>					
	XH 6335 XB	L3XB	SLIP ON	NO	TP-HP4
<b>CB 500 / S 93-04 (PC32)</b>					
	OH 6031 VSE	SOVE	SLIP ON	YES	TP-OV70
	OH 6031 VSEB	XOVE	SLIP ON	YES	TP-OV70
<b>CBF 500 04-11 (PC39)</b>					
	OH 6032 VSE	SOVE	SLIP ON	YES	TP-OV70
	OH 6032 VSEB	XOVE	SLIP ON	YES	TP-OV70
<b>CBR 500 R 13-15 (PC44)</b>					
	FH 6833 SSB	X55SB	SLIP ON	YES	TP-X55SS
	KIT 6133 C1	DKAT	DKAT - FULL COLECTOR	NO	NO
	OH 6033 VSE	SOVE	SLIP ON	YES	TP-OV70
	OH 6033 VSEB	XOVE	SLIP ON	YES	TP-OV70
	OH 6033 VTI	VTI	SLIP ON	YES	TP-OV3
	XH 6333 XB	L3XB	SLIP ON	YES	TP-HP4
<b>CB 500 F 13-15 (PC45)</b>					
	FH 6833 SSB	X55SB	SLIP ON	YES	TP-X55SS
	KIT 6133 C1	DKAT	DKAT - FULL COLECTOR	NO	NO
	OH 6033 VSE	SOVE	SLIP ON	YES	TP-OV70
	OH 6033 VSEB	XOVE	SLIP ON	YES	TP-OV70
	OH 6033 VTI	VTI	SLIP ON	YES	TP-OV3
	XH 6333 XB	L3XB	SLIP ON	YES	TP-HP4

	REFERENCE	RANGE	EXHAUST TYPE	CE	INSIDE
<b>CB 500 X 13-16 (PC46)</b>					
	FH 6833 SSB	X55SB	SLIP ON	YES	TP-X55SS
	OH 6033 VSE	SOVE	SLIP ON	YES	TP-OV70
	OH 6033 VSEB	XOVE	SLIP ON	YES	TP-OV70
	OH 6033 VTI	VTI	SLIP ON	YES	TP-OV3
	XH 6333 XB	L3XB	SLIP ON	YES	TP-HP4
<b>CBR 500 R 16-18 (PC57)</b>					
	FH 6834 SSB	X55SB	SLIP ON	YES	TP-X55SS
	OH 6033 VSE	SOVE	SLIP ON	YES	TP-OV70
	OH 6033 VSEB	XOVE	SLIP ON	YES	TP-OV70
	OH 6033 VTI	VTI	SLIP ON	YES	TP-OV3
	OH 634 RRB	RC1B	SLIP ON	YES	TP-OVC12
	XH 6334 XB	L3XB	SLIP ON	YES	TP-HP4
<b>CB 500 F 16-18 (PC58)</b>					
	FH 6834 SSB	X55SB	SLIP ON	YES	TP-X55SS
	OH 6033 VSE	SOVE	SLIP ON	YES	TP-OV70
	OH 6033 VSEB	XOVE	SLIP ON	YES	TP-OV70
	OH 6033 VTI	VTI	SLIP ON	YES	TP-OV3
	OH 634 RRB	RC1B	SLIP ON	YES	TP-OVC12
	XH 6334 XB	L3XB	SLIP ON	YES	TP-HP4
<b>CB 500 X 17-18 (PC59)</b>					
	FH 6834 SSB	X55SB	SLIP ON	YES	TP-X55SS
	OH 6033 VSE	SOVE	SLIP ON	YES	TP-OV70
	OH 6033 VSEB	XOVE	SLIP ON	YES	TP-OV70
	OH 6033 VTI	VTI	SLIP ON	YES	TP-OV3
	OH 634 RRB	RC1B	SLIP ON	YES	TP-OVC12
	XH 6334 XB	L3XB	SLIP ON	YES	TP-HP4
<b>CBR 500 R 19-20 (PC62)</b>					
	OH 636 RRB	RC1B	SLIP ON	YES	TP-OVC12
	XH 6336 XB	L3XB	SLIP ON	YES	TP-HP4
<b>CB 500 F 19-20 (PC63)</b>					
	OH 636 RRB	RC1B	SLIP ON	YES	TP-OVC12















REFERENCE	RANGE	EXHAUST TYPE	CE	INSIDE
 XH 6336 XB	L3XB	SLIP ON	YES	TP-HP4
<b>CB 500 X 19-20 (PC64)</b>				
 OH 636 RRB	RC1B	SLIP ON	YES	TP-OVC12
 XH 6336 XB	L3XB	SLIP ON	YES	TP-HP4
<b>CB 600 F/S HORNET 07-14 (PC41)</b>				
 FH 6848 SS	X55S	SLIP ON	YES	TP-X55SS
 OH 6048 VSE	SOVE	SLIP ON	YES	TP-OV70
 XH 6348 V	L2X	SLIP ON	YES	NO
<b>CBF 600 04-11 (PC38)</b>				
 OH 6057 VSE	SOVE	SLIP ON	YES	TP-OV70
 OH 6057 VSEB	XOVE	SLIP ON	YES	TP-OV70
<b>CBR 600 F 87-90 (PC19,PC23)</b>				
 OH 6043 VSE	SOVE	SLIP ON	NO	TP-OV70
<b>CBR 600 F 91-98 (PC25,PC31)</b>				
 OH 6041 VSE	SOVE	SLIP ON	YES	TP-OV70
 OH 6041 VSEB	XOVE	SLIP ON	YES	TP-OV70
<b>CBR 600 F 99-00 (PC35)</b>				
 OH 6049 VSE	SOVE	SLIP ON	YES	TP-OV70
 OH 6049 VSEB	XOVE	SLIP ON	YES	TP-OV70
<b>CBR 600 F 01-07 (PC35F)</b>				
 OH 6052 VSE	SOVE	SLIP ON	NO	TP-OV70
 OH 6052 VSEB	XOVE	SLIP ON	NO	TP-OV70
<b>CBR 600 F SPORT 01-02 (PC35H)</b>				
 OH 6052 VSE	SOVE	SLIP ON	NO	TP-OV70
 OH 6052 VSEB	XOVE	SLIP ON	NO	TP-OV70
<b>CBR 600 F 11-14 (PC41)</b>				
 FH 6848 SS	X55S	SLIP ON	YES	TP-X55SS
 OH 6048 VSE	SOVE	SLIP ON	YES	TP-OV70
 XH 6348 V	L2X	SLIP ON	YES	NO
<b>CB 650 F 14-18 (RC75,RC97)</b>				
 FH 6856 SSB	X55SB	FULL SYSTEM	YES	TP-X55SS
 SH 6756 C	SX1	FULL SYSTEM	YES	TP-OV6
 XH 6356 XB	L3XB	FULL SYSTEM	YES	TP-HP4









REFERENCE	RANGE	EXHAUST TYPE	CE	INSIDE
<b>CB 650 R 19-20 (RH02)</b>				
 CH 6156 RC	RC	FULL SYSTEM	YES	NO
 FH 6856 SSB	X55SB	FULL SYSTEM	YES	TP-X55SS
 SH 6756 C	SX1	FULL SYSTEM	YES	TP-OV6
 XH 6356 XB	L3XB	FULL SYSTEM	YES	TP-HP4
<b>CBR 650 F 15-18 (RC74,RC96)</b>				
 FH 6856 SSB	X55SB	FULL SYSTEM	YES	TP-X55SS
 SH 6756 C	SX1	FULL SYSTEM	YES	TP-OV6
 XH 6356 XB	L3XB	FULL SYSTEM	YES	TP-HP4
<b>CBR 650 R 19-20 (RH01)</b>				
 CH 6156 RC	RC	FULL SYSTEM	YES	NO
 FH 6856 SSB	X55SB	FULL SYSTEM	YES	TP-X55SS
 SH 6756 C	SX1	FULL SYSTEM	YES	TP-OV6
 XH 6356 XB	L3XB	FULL SYSTEM	YES	TP-HP4
<b>NC 700 X / S / INTEGRA 12-13 (RC61,RC62,RC63)</b>				
 FH 6862 SSB	X55SB	SLIP ON	YES	TP-X55SS
 OH 6062 VSE	SOVE	SLIP ON	YES	TP-OV70
 OH 6062 VSEB	XOVE	SLIP ON	YES	TP-OV70
 OH 6062 VTI	VTI	SLIP ON	YES	TP-OV3
 XH 6362 XB	L3XB	SLIP ON	YES	TP-HP4
<b>NC 750 X / S / INTEGRA 14-15 (RC70)</b>				
 FH 6862 SSB	X55SB	SLIP ON	YES	TP-X55SS
 OH 6062 VSE	SOVE	SLIP ON	YES	TP-OV70
 OH 6062 VSEB	XOVE	SLIP ON	YES	TP-OV70
 OH 6062 VTI	VTI	SLIP ON	YES	TP-OV3
 XH 6362 XB	L3XB	SLIP ON	YES	TP-HP4
<b>NC 750 X / S / INTEGRA 16-19 (RC88,RC89,RC90,RC92)</b>				
 FH 6862 SSB	X55SB	SLIP ON	YES	TP-X55SS
 OH 6062 VSE	SOVE	SLIP ON	YES	TP-OV70
 OH 6062 VSEB	XOVE	SLIP ON	YES	TP-OV70
 OH 6062 VTI	VTI	SLIP ON	YES	TP-OV3
 XH 6362 XB	L3XB	SLIP ON	YES	TP-HP4











REFERENCE	RANGE	EXHAUST TYPE	CE	INSIDE
<b>X-ADV 750 17-19 (RC95)</b>				
 OH 6059 VSE	SOVE	SLIP ON	YES	TP-OV70
 OH 6059 VTI	VTI	SLIP ON	YES	TP-OV3
 OH 659 RR	RC1	SLIP ON	YES	TP-OVC12
 OH 659 RRB	RC1B	SLIP ON	YES	TP-OVC12
<b>VFR 750 F 90-93 (RC36)</b>				
 OH 6060 VSE	SOVE	SLIP ON	YES	TP-OV70
 OH 6060 VSEB	XOVE	SLIP ON	YES	TP-OV70
<b>VFR 750 F 94-97 (RC36-2)</b>				
 OH 6061 VSE	SOVE	SLIP ON	YES	TP-OV70
 OH 6061 VSEB	XOVE	SLIP ON	YES	TP-OV70
<b>RVF 750 R '94 (RC45)</b>				
 OH 6065 VSE	SOVE	SLIP ON	NO	TP-OV70
<b>VFR 800 Fi 98-01 (RC46)</b>				
 OH 6063 VSE	SOVE	SLIP ON	YES	TP-OV70
<b>VFR 800 X CROSSRUNNER 11-14 (RC60)</b>				
 OH 6068 VSE	SOVE	SLIP ON	YES	TP-OV70
 XH 6368 XB	L3XB	SLIP ON	YES	TP-HP4
<b>VFR 800 F 14-18</b>				
 OH 6058 VSE	SOVE	SLIP ON	NO	TP-OV70
<b>VFR 800 X CROSSRUNNER 15-18 (RC80)</b>				
 OH 6058 VSE	SOVE	SLIP ON	NO	TP-OV70
<b>CB 900 F HORNET 03-07 (SC48)</b>				
 OH 6198 VSE	SOVE	SLIP ON	YES	TP-OV70
<b>CBR 900 RR 92-95 (SC28)</b>				
 OH 6081 VSE	SOVE	BOLT ON	YES	TP-OV70
<b>CBR 900 RR 96-97 (SC29)</b>				
 OH 6087 VSE	SOVE	BOLT ON	NO	TP-OV70
<b>CBR 900 RR 98-99 (SC33)</b>				
 OH 6093 VSE	SOVE	BOLT ON	YES	TP-OV70
<b>CBR 900 RR 00-03 (SC44,SC50)</b>				
 OH 6095 VSE	SOVE	BOLT ON	NO	TP-OV70
 OH 6095 VSEB	XOVE	BOLT ON	NO	TP-OV70
<b>CB 1000 BIG ONE MADE IN JAPAN (SC30A)</b>				
 OH 6083 JVSE	SOVE	BOLT ON	YES	TP-OV70

REFERENCE	RANGE	EXHAUST TYPE	CE	INSIDE
<b>CB 1000 BIG ONE MADE IN USA (SC30)</b>				
 OH 6083 VSE	SOVE	BOLT ON	YES	TP-OV70
<b>CBF 1000 10-15</b>				
 OH 6080 VSE	SOVE	SLIP ON	NO	TP-OV70
<b>VTR 1000 F 97-05 (SC36)</b>				
 OH 6088 VSE	SOVE	SLIP ON (RIGHT MUFFLER)	YES	TP-OV70
 OH 6089 VSE	SOVE	SLIP ON (LEFT MUFFLER)	YES	TP-OV70
<b>VTR 1000 SP1 (SC45)</b>				
 OH 6096 VSE	SOVE	SLIP ON (RIGHT MUFFLER)	YES	TP-OV70
 OH 6097 VSE	SOVE	SLIP ON (LEFT MUFFLER)	YES	TP-OV70
<b>VTR 1000 SP2</b>				
 OH 6072 VSE	SOVE	SLIP ON (RIGHT MUFFLER)	NO	TP-OV70
 OH 6073 VSE	SOVE	SLIP ON (LEFT MUFFLER)	NO	TP-OV70
<b>CB 1000 R HORNET 08-17 (SC60)</b>				
 FH 6877 SS	X55S	SLIP ON	YES	TP-X55SS
 KIT 6077 C1	DKAT	DKAT - MID PIPE	NO	NO
 OH 6077 VSE	SOVE	SLIP ON	YES	TP-OV70
 SH 6777 C	SX1	SLIP ON	NO	TP-OV6
 XH 6377 V	L2X	SLIP ON	YES	NO
<b>CB 1000 R 18-19 (SC80)</b>				
 CH 6278 RC	RC	SLIP ON	YES	NO
 KIT 6178 C1	DKAT	DKAT - FULL COLECTOR	NO	NO
 OH 678 RR	RC1	SLIP ON	YES	TP-OVC12
 OH 678 RRB	RC1B	SLIP ON	YES	TP-OVC12
 XH 6278 XN	L3N	SLIP ON	YES	TP-HP4
<b>CRF 1000 L AFRICA TWIN 16-19 (SD04,SD06)</b>				
 EH 6082 SS	MXT	SLIP ON	YES	TP-MXT80
 OH 6074 VSE	SOVE	SLIP ON	YES	TP-OV70
 OH 6074 VSEB	XOVE	SLIP ON	YES	TP-OV70
<b>CBR 1000 RR 08-14 (SC59)</b>				
 OH 6175 VSE	SOVE	SLIP ON	NO	TP-OV70
<b>CBR 1000 RR 17-19</b>				
 CH 6276 RC	RC	SLIP ON	NO	NO
 OH 676 RRB	RC1B	SLIP ON	NO	TP-OVC12







REFERENCE	RANGE	EXHAUST TYPE	CE	INSIDE
<b>CB 1100 13-15</b>				
 OH 6086 VSE	SOVE	SLIP ON	NO	TP-OV70
<b>CB 1100 EX / RS 16-19</b>				
 HH 6100 SS	HC1-3S	SLIP ON (RIGHT MUFFLER)	NO	TP-OV70
 HH 6101 SS	HC1-3S	SLIP ON (LEFT MUFFLER)	NO	TP-OV70
<b>CBR 1100 XX (SC35)</b>				
 OH 6090 VSE	SOVE	SLIP ON (RIGHT MUFFLER)	YES	TP-OV70
 OH 6091 VSE	SOVE	SLIP ON (LEFT MUFFLER)	YES	TP-OV70
<b>VFR 1200 F 10-17</b>				
 OH 6064 VSE	SOVE	SLIP ON	NO	TP-OV70
<b>VFR 1200 X CROSSTOURER 12-17</b>				
 OH 6071 VSE	SOVE	SLIP ON	NO	TP-OV70
<b>CB 1300 S / CB 1300 SF 03-14 (SC54)</b>				
 OH 6094 VSE	SOVE	SLIP ON	NO	TP-OV70
 OH 6094 VTI	VTI	SLIP ON	NO	TP-OV3

## HYOSUNG























<b>GT 125 COMET</b>				
 OG 4021 VSE	SOVE	BOLT ON	YES	TP-OV70
<b>GT 250 COMET</b>				
 OG 4021 VSE	SOVE	BOLT ON	YES	TP-OV70
<b>GD 250 EXIV</b>				
 OG 4031 VSE	SOVE	SLIP ON	NO	TP-OV70
 XG 4331 XB	L3XB	SLIP ON	NO	TP-HP4
<b>GV 650 AQUILA 06-13</b>				
 OG 4053 VSE	SOVE	BOLT ON	NO	TP-OV70
 OG 4053 VSEB	XOVE	BOLT ON	NO	TP-OV70
<b>GT 650 S / R / Ri (GT650)</b>				
 OG 4051 VSE	SOVE	BOLT ON	YES	TP-OV70
 OG 4051 VSEB	XOVE	BOLT ON	YES	TP-OV70

























## INDIAN

<b>SCOUT 15-19</b>				
 HI 2001 SB	HC1-2B	SLIP ON (UPPER MUFFLER)	NO	TP-OV3
 HI 2001 SC	HC1-2C	SLIP ON (UPPER MUFFLER)	NO	TP-OV3
 HI 2002 SB	HC1-2B	SLIP ON (LOWER MUFFLER)	NO	TP-OV3
 HI 2002 SC	HC1-2C	SLIP ON (LOWER MUFFLER)	NO	TP-OV3

REFERENCE	RANGE	EXHAUST TYPE	CE	INSIDE
<b>SCOUT BOBBER 15-19</b>				
 HI 2001 SB	HC1-2B	SLIP ON (UPPER MUFFLER)	NO	TP-OV3
 HI 2001 SC	HC1-2C	SLIP ON (UPPER MUFFLER)	NO	TP-OV3
 HI 2002 SB	HC1-2B	SLIP ON (LOWER MUFFLER)	NO	TP-OV3
 HI 2002 SC	HC1-2C	SLIP ON (LOWER MUFFLER)	NO	TP-OV3
<b>CHIEF 15-19</b>				
 HI 2018 SB	HC2-1B	SLIP ON (RIGHT MUFFLER)	NO	TP-OV3
 HI 2018 SC	HC2-1C	SLIP ON (RIGHT MUFFLER)	NO	TP-OV3
 HI 2019 SB	HC2-1B	SLIP ON (LEFT MUFFLER)	NO	TP-OV3
 HI 2019 SC	HC2-1C	SLIP ON (LEFT MUFFLER)	NO	TP-OV3
<b>CHIEF DARK HORSE 15-19</b>				
 HI 2018 SB	HC2-1B	SLIP ON (RIGHT MUFFLER)	NO	TP-OV3
 HI 2018 SC	HC2-1C	SLIP ON (RIGHT MUFFLER)	NO	TP-OV3
 HI 2019 SB	HC2-1B	SLIP ON (LEFT MUFFLER)	NO	TP-OV3
 HI 2019 SC	HC2-1C	SLIP ON (LEFT MUFFLER)	NO	TP-OV3
<b>CHIEFTAIN 15-19</b>				
 HI 2016 SB	HC2-1B	SLIP ON (RIGHT MUFFLER)	NO	TP-OV3
 HI 2016 SC	HC2-1C	SLIP ON (RIGHT MUFFLER)	NO	TP-OV3
 HI 2017 SB	HC2-1B	SLIP ON (LEFT MUFFLER)	NO	TP-OV3
 HI 2017 SC	HC2-1C	SLIP ON (LEFT MUFFLER)	NO	TP-OV3
<b>ROADMASTER 15-19</b>				
 HI 2016 SB	HC2-1B	SLIP ON (RIGHT MUFFLER)	NO	TP-OV3
 HI 2016 SC	HC2-1C	SLIP ON (RIGHT MUFFLER)	NO	TP-OV3
 HI 2017 SB	HC2-1B	SLIP ON (LEFT MUFFLER)	NO	TP-OV3
 HI 2017 SC	HC2-1C	SLIP ON (LEFT MUFFLER)	NO	TP-OV3
<b>SPRINGFIELD 15-19</b>				
 HI 2016 SB	HC2-1B	SLIP ON (RIGHT MUFFLER)	NO	TP-OV3
 HI 2016 SC	HC2-1C	SLIP ON (RIGHT MUFFLER)	NO	TP-OV3
 HI 2017 SB	HC2-1B	SLIP ON (LEFT MUFFLER)	NO	TP-OV3
 HI 2017 SC	HC2-1C	SLIP ON (LEFT MUFFLER)	NO	TP-OV3
<b>FTR 1200 / FTR 1200 S 18-20</b>				
 DKAT KIT 2220 C1	DKAT	DKAT - MID PIPE	NO	NO



























REFERENCE	RANGE	EXHAUST TYPE	CE	INSIDE
<b>ITALJET DRAGSTER 50 - MINARELLI HORIZONTAL</b>				
 YAM 2326	SCCL	FULL SYSTEM	NO	NO
<b>ITALJET FORMULA L.C. - MINARELLI HORIZONTAL</b>				
 YAM 2326	SCCL	FULL SYSTEM	NO	NO
<b>ITALJET PISTA 50 - MINARELLI VERTICAL</b>				
 YAM 2334	SCCL	FULL SYSTEM	NO	NO
<b>ITALJET SCOOP / REPORTER 50 - MINARELLI VERTICAL</b>				
 YAM 2334	SCCL	FULL SYSTEM	NO	NO
<b>KAWASAKI</b>				
<b>Z 125 / NINJA 125 2019</b>				
 OK 7037 VSEB	XOVE	SLIP ON	NO	TP-OV70
 XK 7337 XB	L3XB	SLIP ON	NO	TP-HP4
<b>NINJA 250 R 08-12 (EX250K)</b>				
 FK 7834 SSB	X55SB	SLIP ON	YES	TP-X55SS
 OK 7034 VSE	SOVE	SLIP ON	YES	TP-OV70
 XK 7334 XB	L3XB	SLIP ON	YES	TP-HP4
<b>NINJA 250-300 R 13-15 (ER300A)</b>				
 FK 7836 SS	X55S	SLIP ON	YES	TP-X55SS
 OK 7036 VSE	SOVE	SLIP ON	YES	TP-OV70
 XK 7336 XB	L3XB	SLIP ON	YES	TP-HP4
<b>NINJA 250-300 R 13-15</b>				
 OK 7136 VSE	SOVE	FULL SYSTEM	NO	TP-OV70
<b>NINJA 250 SL / Z 250 SL 15-17</b>				
 OK 7037 VSEB	XOVE	SLIP ON	NO	TP-OV70
 XK 7337 XB	L3XB	SLIP ON	NO	TP-HP4
<b>Z 300 (EX300A)</b>				
 FK 7836 SS	X55S	SLIP ON	YES	TP-X55SS
 OK 7036 VSE	SOVE	SLIP ON	YES	TP-OV70
 OK 7136 VSE	SOVE	FULL SYSTEM	NO	TP-OV70
 XK 7336 XB	L3XB	SLIP ON	YES	TP-HP4
<b>VERSYS-X 300 17-19 (LE300C)</b>				
 OK 7039 VSE	SOVE	SLIP ON	NO	TP-OV70
<b>NINJA 400 18-19 (EX400G)</b>				
 CK 7240 RC	RC	SLIP ON	NO	NO
 OK 7140 RR	RC1	FULL SYSTEM (SSP300)	NO	NO

















REFERENCE	RANGE	EXHAUST TYPE	CE	INSIDE
 OK 740 RRB	RC1B	SLIP ON	NO	TP-OVC12
 OK 7540 VTR	VTI	FULL SYSTEM (SSP300)	NO	NO
 XK 7240 XN	L3N	SLIP ON	NO	TP-HP2
<b>Z 400 2019 (EX400G)</b>				
 CK 7240 RC	RC	SLIP ON	NO	NO
 OK 7140 RR	RC1	FULL SYSTEM (SSP300)	NO	TP-OVC12
 OK 740 RRB	RC1B	SLIP ON	NO	TP-OVC12
 OK 7540 VTR	VTI	FULL SYSTEM (SSP300)	NO	NO
 XK 7240 XN	L3N	SLIP ON	NO	TP-HP2
<b>GPZ 500 / S (EX500)</b>				
 OK 7032 VSE	SOVE	SLIP ON (RIGHT MUFFLER)	NO	TP-OV70
 OK 7033 VSE	SOVE	SLIP ON (LEFT MUFFLER)	NO	TP-OV70
<b>ER-5 (ER500A)</b>				
 OK 7031 VSE	SOVE	SLIP ON	YES	TP-OV70
<b>ZEPHYR 550 (ZR550B)</b>				
 OK 7021 VSE	SOVE	SLIP ON	NO	TP-OV70
<b>ER-6 05-11 (EX650A,C,D / ER650A,C,D)</b>				
 OK 7050 VSE	SOVE	SLIP ON	YES	TP-OV70
 OK 7050 VSEB	XOVE	SLIP ON	YES	TP-OV70
 XK 7351 XB	L3XB	SLIP ON	YES	TP-HP4
<b>ER-6 12-16 (EX650E,F / ER650E,F)</b>				
 FK 7852 SSB	X55SB	FULL SYSTEM	YES	TP-X55SS
 OK 7052 VSE	SOVE	FULL SYSTEM	YES	TP-OV70
 SK 7752 C	SX1	FULL SYSTEM	YES	TP-OV6
 XK 7352 XB	L3XB	FULL SYSTEM	NO	TP-HP4
<b>Z650 / NINJA 650 17-19 (ER650H,EX650K)</b>				
 CK 7153 RC	RC	FULL SYSTEM	YES	NO
 FK 7853 SSB	X55SB	FULL SYSTEM	YES	TP-X55SS
 OK 7053 VSE	SOVE	FULL SYSTEM	YES	TP-OV70
 OK 753 RRB	RC1B	FULL SYSTEM	YES	TP-OVC12
 SK 7753 C	SX1	FULL SYSTEM	YES	TP-OV6
 XK 7353 XB	L3XB	FULL SYSTEM	YES	TP-HP4





















REFERENCE	RANGE	EXHAUST TYPE	CE	INSIDE
<b>VN 650 VULCAN S 15-19</b>				
 SK 7755 C	SX1	FULL SYSTEM	NO	TP-OV6
<b>ZX-6 R NINJA 94-97 (ZX600F)</b>				
 OK 7041 VSE	SOVE	BOLT ON	YES	TP-OV70
<b>ZX-6 R NINJA 98-02 (ZX600G)</b>				
 OK 7045 VSE	SOVE	BOLT ON	YES	TP-OV70
<b>ZX 636 R 02 (ZX636A)</b>				
 OK 7045 VSE	SOVE	BOLT ON	NO	TP-OV70
<b>ZX 636 R / RR 03-04 (ZX636B)</b>				
 OK 7047 VSE	SOVE	SLIP ON	YES	TP-OV70
<b>ZX-6 R 09-13 (ZX600R)</b>				
 DKAT KIT 7144 C1	DKAT	DKAT - MID PIPE	NO	NO
 OK 7144 VSE	SOVE	SLIP ON	NO	TP-OV70
 XK 7344 V	L2X	SLIP ON	NO	NO
<b>ZX 636 R 13-19</b>				
 DKAT KIT 7144 C1	DKAT	DKAT - MID PIPE	NO	NO
 OK 7144 VSE	SOVE	SLIP ON	NO	TP-OV70
 OK 7544 VTR	VTI	SLIP ON (SBK EDITION)	NO	NO
 XK 7344 V	L2X	SLIP ON	NO	NO
<b>VERSYS 650 06-14 (LE650A,C,D,E)</b>				
 OK 7050 VSE	SOVE	SLIP ON	YES	TP-OV70
 OK 7050 VSEB	XOVE	SLIP ON	YES	TP-OV70
 XK 7351 XB	L3XB	SLIP ON	YES	TP-HP4
<b>VERSYS 650 15-19 (LE650E,F)</b>				
 FK 7852 SSB	X55SB	FULL SYSTEM	YES	TP-X55SS
 OK 7052 VSE	SOVE	FULL SYSTEM	YES	TP-OV70
 SK 7752 C	SX1	FULL SYSTEM	YES	TP-OV6
 XK 7352 XB	L3XB	FULL SYSTEM	NO	TP-HP4
<b>ZR-7 F / S (ZR750F,ZR750H)</b>				
 OK 7067 VSE	SOVE	BOLT ON	NO	TP-OV70
<b>Z 750 / S 04-06 (ZR750J)</b>				
 OK 7069 VSE	SOVE	SLIP ON	YES	TP-OV70
 OK 7069 VSEB	XOVE	SLIP ON	YES	TP-OV70
 XK 7369 V	L2X	SLIP ON	NO	NO

REFERENCE	RANGE	EXHAUST TYPE	CE	INSIDE
<b>Z 750 S / R 07-12 (ZR750L)</b>				
 FK 7871 SS	X55S	SLIP ON	YES	TP-X55SS
 OK 7071 VSE	SOVE	SLIP ON	YES	TP-OV70
 XK 7371 V	L2X	SLIP ON	NO	NO
 XK 7371 XB	L3XB	SLIP ON	YES	TP-HP4
<b>ZXR 750 91-95 (ZX750L)</b>				
 OK 7063 VSE	SOVE	BOLT ON	YES	TP-OV70
<b>ZX-7 R NINJA 96-99 (ZX750P)</b>				
 OK 7065 VSE	SOVE	BOLT ON	YES	TP-OV70
<b>Z 800 13-16 (ZR800A,ZR800B)</b>				
 FK 7868 SSB	X55SB	SLIP ON	YES	TP-X55SS
 DKAT KIT 7168 C1	DKAT	DKAT - FULL COLECTOR	NO	NO
 OK 7068 VSE	SOVE	SLIP ON	YES	TP-OV70
 OK 768 RRB	RC1B	SLIP ON	YES	TP-OVC12
 XK 7368 XB	L3XB	SLIP ON	YES	TP-HP4
<b>Z 800 e 13-16 (ZR800C,ZR800D)</b>				
 FK 7862 SSB	X55SB	SLIP ON	YES	TP-X55SS
 OK 7062 VSE	SOVE	SLIP ON	YES	TP-OV70
 OK 762 RRB	RC1B	SLIP ON	YES	TP-OVC12
 XK 7362 XB	L3XB	SLIP ON	YES	TP-HP4
<b>W800</b>				
 OK 760 SS	OVC13	FULL SYSTEM (2-1)	NO	TP-OV3
<b>Z 900 FULL 16-19 (ZR900B)</b>				
 CK 7272 RC	RC	SLIP ON	YES	NO
 FK 7172 SS	X55S	FULL SYSTEM (Z CUP)	NO	TP-X55SS
 FK 7872 SSB	X55SB	SLIP ON	YES	TP-X55SS
 DKAT KIT 7172 C1	DKAT	DKAT - FULL COLECTOR	NO	NO
 OK 7072 VSE	SOVE	SLIP ON	YES	TP-OV70
 OK 772 RRB	RC1B	SLIP ON	YES	TP-OVC12
 SK 7772 C	SX1	FULL SYSTEM	YES	TP-OV6
 XK 7372 XB	L3XB	SLIP ON	YES	TP-HP4
<b>Z 900 FULL 2020 (ZR900F)</b>				
 CK 7258 RC	RC	SLIP ON	YES	TP-OVC12









	REFERENCE	RANGE	EXHAUST TYPE	CE	INSIDE
	KIT 7158 C1	DKAT	DKAT - FULL COLECTOR	NO	NO
	OK 7258 RRB	RC1B	SLIP ON	YES	TP-OVC12
	SK 7772 C	SX1	FULL SYSTEM	YES	TP-OV6
	XK 7258 XN	L3N	SLIP ON	YES	TP-HP2
<b>Z 900 A2 17-19 (ZR900D,ZR900DA2)</b>					
	CK 7272 RC	RC	SLIP ON	YES	NO
	FK 7872 SSB	X55SB	SLIP ON	YES	TP-X55SS
	KIT 7173 C1	DKAT	DKAT - FULL COLECTOR	NO	NO
	OK 7072 VSE	SOVE	SLIP ON	YES	TP-OV70
	OK 772 RRB	RC1B	SLIP ON	YES	TP-OVC12
	XK 7372 XB	L3XB	SLIP ON	YES	TP-HP4
<b>Z 900 A2 2020 (ZR900H,ZR900HA2)</b>					
	CK 7272 RC	RC	SLIP ON	YES	NO
	FK 7872 SSB	X55SB	SLIP ON	YES	TP-X55SS
	KIT 7173 C1	DKAT	DKAT - FULL COLECTOR	NO	NO
	OK 7072 VSE	SOVE	SLIP ON	YES	TP-OV70
	OK 772 RRB	RC1B	SLIP ON	YES	TP-OVC12
	XK 7372 XB	L3XB	SLIP ON	YES	TP-HP4
<b>Z 900 RS 18-19 (ZR900C)</b>					
	KIT 7170 C1	DKAT	DKAT - FULL COLECTOR	NO	NO
	OK 770 RR	RC1	SLIP ON	YES	TP-OVC12
	OK 770 RRB	RC1B	SLIP ON	YES	TP-OVC12
<b>ZX-9 R NINJA 94-97 (ZX900B)</b>					
	OK 7083 VSE	SOVE	SLIP ON	YES	TP-OV70
<b>ZX-9 R NINJA 98-01 (ZX900C)</b>					
	OK 7087 VSE	SOVE	BOLT ON	YES	TP-OV70
	OK 7087 VSEB	XOVE	BOLT ON	YES	TP-OV70
<b>Z 1000 03-06 (ZRT00A)</b>					
	OK 7195 VSE	SOVE	SLIP ON (2 in 1)	YES	TP-OV70
	OK 7195 VSEB	XOVE	SLIP ON (2 in 1)	YES	TP-OV70
<b>Z 1000 07-09 (ZRT00B)</b>					
	OK 7078 VSE	SOVE	SLIP ON (RIGHT MUFFLER)	NO	TP-OV70
	OK 7079 VSE	SOVE	SLIP ON (LEFT MUFFLER)	NO	TP-OV70

	REFERENCE	RANGE	EXHAUST TYPE	CE	INSIDE
	XK 7378 XB	L3XB	SLIP ON (RIGHT MUFFLER)	NO	TP-HP4
	XK 7379 XB	L3XB	SLIP ON (LEFT MUFFLER)	NO	TP-HP4
<b>Z 1000 / Z 1000 SX 10-19 (ZRT00D,E,F,H / ZXT00G,I,W)</b>					
	FK 7874 S2	X55SP	FULL SYSTEM	NO	TP-X55SS
	FK 7874 SS	X55S	SLIP ON (RIGHT MUFFLER)	YES	TP-X55SS
	FK 7874 SSB	X55SB	SLIP ON (RIGHT MUFFLER)	YES	TP-X55SS
	FK 7875 SS	X55S	SLIP ON (LEFT MUFFLER)	YES	TP-X55SS
	FK 7875 SSB	X55SB	SLIP ON (LEFT MUFFLER)	YES	TP-X55SS
	OK 7074 VSE	SOVE	SLIP ON (RIGHT MUFFLER)	YES	TP-OV70
	OK 7075 VSE	SOVE	SLIP ON (LEFT MUFFLER)	YES	TP-OV70
	OK 774 RRB	RC1B	SLIP ON (RIGHT MUFFLER)	YES	TP-OVC12
	OK 775 RRB	RC1B	SLIP ON (LEFT MUFFLER)	YES	TP-OVC12
	SK 7774 C	SX1	FULL SYSTEM	YES	TP-OV6
	XK 7374 V	L2X	SLIP ON (RIGHT MUFFLER)	YES	NO
	XK 7375 V	L2X	SLIP ON (LEFT MUFFLER)	YES	NO
<b>ZX 10 R 04-05 (ZRT00C)</b>					
	OK 7297 VSE	SOVE	BOLT ON	YES	TP-OV70
<b>ZX 10 R 08-10 (ZXT00E)</b>					
	KIT 7199 C1	DKAT	DKAT - MID PIPE	NO	NO
	OK 7199 VSE	SOVE	SLIP ON	NO	TP-OV70
	XK 7399 V	L2X	SLIP ON	NO	NO
<b>ZX 10 R 11-19</b>					
	CK 7290 RC	RC	SLIP ON	NO	NO
	KIT 7090 C1	DKAT	DKAT - MID PIPE	NO	NO
	OK 7090 VSE	SOVE	SLIP ON	NO	TP-OV70
	OK 7590 VTR	VTI	SLIP ON (SBK EDITION)	NO	NO
<b>H2 15-18</b>					
	FK 7896 S2	X55SP	SLIP ON	NO	TP-X55SS
	OK 7096 VSE	SOVE	SLIP ON	NO	TP-OV70
<b>H2 SX / SX SE 18-19</b>					
	OK 782 RR	RC1	SLIP ON	NO	TP-OVC12
<b>VERSYS 1000 12-19 (LZT00A,LZT00B)</b>					
	OK 7084 VSE	SOVE	SLIP ON	YES	TP-OV70





















	REFERENCE	RANGE	EXHAUST TYPE	CE	INSIDE
	OK 7084 VSEB	XOVE	SLIP ON	YES	TP-OV70
	SK 7774 C	SX1	FULL SYSTEM	YES	TP-OV6
<b>ZRX 1100 / ZRX 1100 II (ZRT10C)</b>					
	OK 7085 VSE	SOVE	BOLT ON	YES	TP-OV70
	OK 7085 VSEB	XOVE	BOLT ON	YES	TP-OV70
<b>ZX-12R NINJA (ZXT20A)</b>					
	OK 7091 VSE	SOVE	BOLT ON	YES	TP-OV70
<b>ZZR 1200 02-03</b>					
	OK 7092 VSE	SOVE	SLIP ON (RIGHT MUFFLER)	NO	TP-OV70
	OK 7093 VSE	SOVE	SLIP ON (LEFT MUFFLER)	NO	TP-OV70
<b>ZRX 1200 S / R 01-07 (ZRT20A)</b>					
	OK 7089 VSE	SOVE	BOLT ON	NO	TP-OV70
	OK 7089 VSEB	XOVE	BOLT ON	NO	TP-OV70
<b>ZZR 1400 06-07 (ZXT40A, ZXT40C)</b>					
	OK 7177 VSE	SOVE	SLIP ON (2 in 1)	NO	TP-OV70
<b>ZZR 1400 08-11</b>					
	OK 7176 VSE	SOVE	SLIP ON (RIGHT SIDE ONLY)	NO	TP-OV70
<b>ZZR 1400 '12-13</b>					
	OK 7186 VSE	SOVE	SLIP ON (RIGHT SIDE ONLY)	NO	TP-OV70
	OK 7286 VSE	SOVE	SLIP ON (RIGHT & LEFT MUFFLERS)	NO	TP-OV70
<b>ZX-14 R '12-13</b>					
	OK 7286 VSE	SOVE	SLIP ON (RIGHT & LEFT MUFFLERS)	NO	TP-OV70
<b>GTR 1400 10-14</b>					
	OK 7088 VSE	SOVE	SLIP ON	NO	TP-OV70

**KTM**

<b>DUKE 125 / 200 11-16</b>					
	OM 3050 VSE	SOVE	SLIP ON	NO	TP-OV70
	XM 3350 XB	L3XB	SLIP ON	NO	TP-HP4
<b>DUKE / RC 125 17-19</b>					
	CM 3257 RC	RC	SLIP ON	YES	NO
	OM 357 RRB	RC1B	SLIP ON	YES	TP-OVC12
	XM 3257 XN	L3N	SLIP ON	YES	TP-OVC12
	XM 3357 XB	L3XB	SLIP ON	YES	TP-HP4
<b>DUKE / RC 390 17-19</b>					
	CM 3257 RC	RC	SLIP ON	YES	NO

	REFERENCE	RANGE	EXHAUST TYPE	CE	INSIDE
	KIT 3057 C1	DKAT	DKAT - MID PIPE	NO	NO
	OM 357 RRB	RC1B	SLIP ON	YES	TP-OVC12
	XM 3257 XN	L3N	SLIP ON	YES	TP-OVC12
	XM 3357 XB	L3XB	SLIP ON	YES	TP-HP4
<b>RC 125 / 200 15-16</b>					
	OM 3051 VSE	SOVE	SLIP ON	NO	TP-OV70
	XM 3351 XB	L3XB	SLIP ON	NO	TP-HP4
<b>DUKE 390 12-16</b>					
	OM 3052 VSE	SOVE	SLIP ON	NO	TP-OV70
	XM 3352 XB	L3XB	SLIP ON	NO	TP-HP4
<b>RC 390 15-16</b>					
	OM 3053 VSE	SOVE	SLIP ON	NO	TP-OV70
	XM 3353 XB	L3XB	SLIP ON	NO	TP-HP4
<b>DUKE 690 (KMT690) 12-16</b>					
	OM 3070 VSE	SOVE	SLIP ON	YES	TP-OV70
	XM 3370 XB	L3XB	SLIP ON	YES	TP-HP4
<b>DUKE 790 (KMT790) 18-19</b>					
	CM 3279 RC	RC	SLIP ON	YES	NO
	OM 379 RRB	RC1B	SLIP ON	YES	TP-OVC12
	XM 3279 XN	L3N	SLIP ON	YES	TP-HP2
<b>DUKE 790 ADVENTURE 19-20</b>					
	CM 3278 RC	RC	SLIP ON	YES	TP-OVC12
	OM 378 RRB	RC1B	SLIP ON	YES	TP-OVC12
	XM 3278 XN	L3N	SLIP ON	YES	TP-OVC12
<b>1090 ADVENTURE 17-19</b>					
	EM 3089 SS	MXT	SLIP ON	YES	TP-MXT80
<b>1190 ADVENTURE 13-16</b>					
	EM 3089 SS	MXT	SLIP ON	YES	TP-MXT80
<b>1290 ADVENTURE 15-19</b>					
	EM 3089 SS	MXT	SLIP ON	YES	TP-MXT80
<b>SUPERDUKE 1290 14-15</b>					
	KIT 3080 C1	DKAT	DKAT - MID PIPE	NO	NO
	OM 3080 VSE	SOVE	SLIP ON	NO	TP-OV70



REFERENCE	RANGE	EXHAUST TYPE	CE	INSIDE
<b>SUPERDUKE 1290 R / GT 17-18</b>				
 CM 3282 RC	RC	SLIP ON	NO	NO
<b>KYMCO</b>				
<b>CXS CURIO 50</b>				
 K 301	SCCL	FULL SYSTEM	NO	NO
<b>DINK 50 L.C.</b>				
 K 304	SCCL	FULL SYSTEM	YES	NO
<b>DJR / DJ WORLD 50</b>				
 K 301	SCCL	FULL SYSTEM	YES	NO
<b>HEROISM 50</b>				
 K 304	SCCL	FULL SYSTEM	NO	NO
<b>SCOUT 50</b>				
 K 301	SCCL	FULL SYSTEM	NO	NO
<b>SNIPPER 50</b>				
 K 304	SCCL	FULL SYSTEM	NO	NO
<b>SPACER 50 / PEOPLE 50</b>				
 K 304	SCCL	FULL SYSTEM	NO	NO
<b>SUPER 9</b>				
 K 304	SCCL	FULL SYSTEM	NO	NO
<b>TOP BOY 50</b>				
 K 304	SCCL	FULL SYSTEM	NO	NO
<b>ZX 50</b>				
 K 301	SCCL	FULL SYSTEM	NO	NO
<b>COBRA 50 RACER / CROSS</b>				
 K 304	SCCL	FULL SYSTEM	NO	NO
<b>MXer 150 02-04</b>				
 AC 2412 EV	SOVE	FULL SYSTEM	NO	TP-OV70
<b>MXU 250 04-05 (L6)</b>				
 AC 2432 EV	SOVE	FULL SYSTEM	YES	TP-OV70
<b>KXR 250 03-05 (L3)</b>				
 AC 2431 EV	SOVE	FULL SYSTEM	YES	TP-OV70
<b>XCITING 300</b>				
 XK 0330 XS	L5X	SLIP ON	NO	NO
<b>XCITING 400</b>				
 XK 0339 XS	L5X	SLIP ON	NO	NO
<b>AK 550 (E1-A3)</b>				
 XK 0350 XS	L5X	FULL SYSTEM	YES	TP-OV3

**MACAL**

REFERENCE	RANGE	EXHAUST TYPE	CE	INSIDE
<b>CY 50 - MINARELLI HORIZONTAL</b>				
 YAM 2326	SCCL	FULL SYSTEM	NO	NO
<b>MALAGUTI</b>				
<b>CENTRO 50 - MINARELLI HORIZONTAL</b>				
 YAM 2326	SCCL	FULL SYSTEM	NO	NO
<b>CIAK - MINARELLI HORIZONTAL</b>				
 YAM 2326	SCCL	FULL SYSTEM	NO	NO
<b>CROSSER - MINARELLI HORIZONTAL</b>				
 YAM 2326	SCCL	FULL SYSTEM	NO	NO
<b>F-10 JETLINE - MINARELLI HORIZONTAL</b>				
 YAM 2326	SCCL	FULL SYSTEM	NO	NO
<b>F-12 PHANTOM L.C. - MINARELLI HORIZONTAL</b>				
 YAM 2326	SCCL	FULL SYSTEM	NO	NO
<b>F15 FIREFOX - MINARELLI HORIZONTAL</b>				
 YAM 2326	SCCL	FULL SYSTEM	NO	NO
<b>MBK</b>				
<b>BOOSTER - MINARELLI VERTICAL</b>				
 YAM 2334	SCCL	FULL SYSTEM	NO	NO
<b>EVOLIS - MINARELLI HORIZONTAL</b>				
 YAM 2326	SCCL	FULL SYSTEM	NO	NO
<b>FIZZ 50 - MINARELLI HORIZONTAL</b>				
 YAM 2326	SCCL	FULL SYSTEM	NO	NO
<b>FLIPPER - MINARELLI HORIZONTAL</b>				
 YAM 2326	SCCL	FULL SYSTEM	NO	NO
<b>FORTE 50 - MINARELLI HORIZONTAL</b>				
 YAM 2326	SCCL	FULL SYSTEM	NO	NO
<b>NEXT GENERATION 50 - MINARELLI VERTICAL</b>				
 YAM 2334	SCCL	FULL SYSTEM	NO	NO
<b>NITRO 50 - MINARELLI HORIZONTAL</b>				
 YAM 2326	SCCL	FULL SYSTEM	NO	NO
<b>OVETTO - MINARELLI VERTICAL</b>				
 YAM 2334	SCCL	FULL SYSTEM	NO	NO
<b>SORRISO 50 - MINARELLI VERTICAL</b>				
 YAM 2334	SCCL	FULL SYSTEM	NO	NO
<b>STUNT - MINARELLI VERTICAL</b>				
 YAM 2334	SCCL	FULL SYSTEM	NO	NO
<b>TARGET 50 - MINARELLI VERTICAL</b>				
 YAM 2334	SCCL	FULL SYSTEM	NO	NO



REFERENCE	RANGE	EXHAUST TYPE	CE	INSIDE
-----------	-------	--------------	----	--------





### MONDIAL

#### HPS 125 / 150





 KIT 019 C1	DKAT	DKAT - FULL COLECTOR	NO	NO
 OA 619 RR	RC1	SLIP ON	YES	TP-OVC12
 XA 0319 V	L2X	SLIP ON	YES	NO

### MOTO GUZZI

#### V7 II

 OM 334 SSB	OVC11SB	SLIP ON (RIGHT MUFFLER)	NO	TP-OV3
 OM 334 SSS	OVC11SS	SLIP ON (RIGHT MUFFLER)	NO	TP-OV3
 OM 335 SSB	OVC11SB	SLIP ON (LEFT MUFFLER)	NO	TP-OV3
 OM 335 SSS	OVC11SS	SLIP ON (LEFT MUFFLER)	NO	TP-OV3

#### V7 III

 OM 332 SSB	OVC11SB	SLIP ON (RIGHT MUFFLER)	NO	TP-OV3
 OM 332 SSS	OVC11SS	SLIP ON (RIGHT MUFFLER)	NO	TP-OV3
 OM 333 SSB	OVC11SB	SLIP ON (LEFT MUFFLER)	NO	TP-OV3
 OM 333 SSS	OVC11SS	SLIP ON (LEFT MUFFLER)	NO	TP-OV3

### PEUGEOT

#### BUXY 50 <98

 P 234	SCCL	FULL SYSTEM	NO	NO
---	------	-------------	----	----

#### BUXY 50 98>

 P 230	SCCL	FULL SYSTEM	NO	NO
---	------	-------------	----	----

#### ELYSEO 50

 P 230	SCCL	FULL SYSTEM	NO	NO
---	------	-------------	----	----

#### LUDIX 50 ONE AIR

 P 235	SCCL	FULL SYSTEM	NO	NO
---	------	-------------	----	----

#### LUDIX 50 CLASSIC AIR

 P 235	SCCL	FULL SYSTEM	NO	NO
---	------	-------------	----	----

#### SPEEDFIGHT I 50 AIR / L.C.

 P 230	SCCL	FULL SYSTEM	YES	NO
---	------	-------------	-----	----

#### SPEEDAKE 50

 P 230	SCCL	FULL SYSTEM	NO	NO
---	------	-------------	----	----

#### SPEEDFIGHT II 50 L.C.

 P 230	SCCL	FULL SYSTEM	NO	NO
---	------	-------------	----	----

#### SQUAB 50

 P 230	SCCL	FULL SYSTEM	NO	NO
---	------	-------------	----	----

### ST 50 - 50 RAPIDO

 HP 1951	SCCL	FULL SYSTEM	NO	NO
---	------	-------------	----	----

### TREKKER 50

 P 230	SCCL	FULL SYSTEM	YES	NO
---	------	-------------	-----	----

### VIVA CITY 50

 P 230	SCCL	FULL SYSTEM	YES	NO
---	------	-------------	-----	----

### ZENITH 50 <98

 P 234	SCCL	FULL SYSTEM	NO	NO
---	------	-------------	----	----

### ZENITH 50 98>

 P 230	SCCL	FULL SYSTEM	NO	NO
---	------	-------------	----	----

### PIAGGIO

#### PIAGGIO EXTREME

 V 280	SCCL	FULL SYSTEM	NO	NO
---	------	-------------	----	----

#### PIAGGIO FREE 50

 V 280	SCCL	FULL SYSTEM	NO	NO
---	------	-------------	----	----

#### PIAGGIO ZIP 50 2T <'08

 V 280	SCCL	FULL SYSTEM	NO	NO
---	------	-------------	----	----

#### PIAGGIO ZIP 50 2T 09-10

 V 280	SCCL	FULL SYSTEM	NO	NO
--	------	-------------	----	----

#### PIAGGIO LIBERTY 50

 V 280	SCCL	FULL SYSTEM	NO	NO
---	------	-------------	----	----

#### PIAGGIO NRG/MC2/MC3

 V 280	SCCL	FULL SYSTEM	YES	NO
---	------	-------------	-----	----

#### PIAGGIO NTT 50

 V 280	SCCL	FULL SYSTEM	NO	NO
---	------	-------------	----	----

#### PIAGGIO STORM 50

 V 280	SCCL	FULL SYSTEM	NO	NO
---	------	-------------	----	----

#### PIAGGIO TYPHOON 50

 V 280	SCCL	FULL SYSTEM	NO	NO
---	------	-------------	----	----

### RIEJU

#### F-10 - MINARELLI HORIZONTAL

 YAM 2326	SCCL	FULL SYSTEM	NO	NO
--	------	-------------	----	----

#### FIRST / WINDY 50 - MINARELLI HORIZONTAL

 YAM 2326	SCCL	FULL SYSTEM	NO	NO
--	------	-------------	----	----



#### RS-3 125

 OR 3100 VSE	SOVE	SLIP ON	NO	TP-OV70
---	------	---------	----	---------

#### CENTURY 125 17-19

 KIT 019 C1	DKAT	DKAT - FULL COLECTOR	NO	NO
--	------	----------------------	----	----



	REFERENCE	RANGE	EXHAUST TYPE	CE	INSIDE
	OA 619 RR	RC1	SLIP ON	NO	TP-OVC12
	XA 0319 V	L2X	SLIP ON	NO	NO

### ROYAL ENFIELD

#### BULLET 350 - 500

	HR 5003 SB	HC2-2B	SLIP ON	NO	TP-OV3
	HR 5003 SC	HC2-2C	SLIP ON	NO	TP-OV3

### SIAMOTO

#### BIRDIE 50 - MINARELLI HORIZONTAL

	YAM 2326	SCCL	FULL SYSTEM	NO	NO
---	----------	------	-------------	----	----

#### MAT 50 - MINARELLI HORIZONTAL

	YAM 2326	SCCL	FULL SYSTEM	NO	NO
---	----------	------	-------------	----	----

#### SCROSS - FRANCO MORINI

	SZ 2820	SCCL	FULL SYSTEM	NO	NO
---	---------	------	-------------	----	----

#### TOP RACING 50 -MINARELLI HORIZONTAL

	YAM 2326	SCCL	FULL SYSTEM	NO	NO
---	----------	------	-------------	----	----

### SUZUKI

#### KATANA 50 / R

	SZ 2822	SCCL	FULL SYSTEM	NO	NO
--	---------	------	-------------	----	----

#### ADDRESS 50 / R - FRANCO MORINI

	SZ 2820	SCCL	FULL SYSTEM	NO	NO
---	---------	------	-------------	----	----

#### ESTILETE 50

	SZ 2822	SCCL	FULL SYSTEM	NO	NO
---	---------	------	-------------	----	----



#### ZILLION 50

	SZ 2822	SCCL	FULL SYSTEM	NO	NO
---	---------	------	-------------	----	----



#### VAN VAN 125

	OS 8015 VSE	SOVE	SLIP ON	NO	TP-OV70
---	-------------	------	---------	----	---------



#### GSX-S 125 17-19 (WDL0)





















	OS 812 RR	RC1	FULL SYSTEM	YES	TP-OVC12
	OS 812 RRB	RC1B	FULL SYSTEM	YES	TP-OVC12

#### GSX-R 125 17-19 (WDL0)

	OS 812 RR	RC1	FULL SYSTEM	YES	TP-OVC12
	OS 812 RRB	RC1B	FULL SYSTEM	YES	TP-OVC12

#### INAZUMA GW 250 12-15

	OS 8122 VSE	SOVE	FULL SYSTEM (2 in 1)	NO	TP-OV70
	XS 8322 XB	L3XB	SLIP ON	NO	TP-HP4
	XS 8323 XB	L3XB	SLIP ON	NO	TP-HP4























	REFERENCE	RANGE	EXHAUST TYPE	CE	INSIDE
<b>GSX-R 250 17-19</b>					
	OS 835 RRB	RC1B	SLIP ON	NO	TP-OVC12
<b>DL 250 V-STROM 17-19</b>					
	OS 835 RRB	RC1B	SLIP ON	NO	TP-OVC12
<b>LTZ 400 QUADSPORT 03-04</b>					
	AS 8425 EV	SOVE	QRACE OVAL INOX - SILENCER	NO	TP-OV70
<b>GSF 400 N BANDIT (GK75B)</b>					
	OS 8021 VSE	SOVE	SLIP ON	NO	TP-OV70
<b>GS 500 E &lt;03 (GM51A,GM51B)</b>					
	OS 8031 VSE	SOVE	SLIP ON	YES	TP-OV70
<b>GS 500 F 04-10 (BK)</b>					
	OS 8031 VSE	SOVE	SLIP ON	YES	TP-OV70
<b>GSF 600 N BANDIT 94-00 (GN77A)</b>					
	OS 8045 VSE	SOVE	SLIP ON	YES	TP-OV70
	OS 8045 VSEB	XOVE	SLIP ON	YES	TP-OV70
<b>GSF 600 N BANDIT 01-04 (WVA8)</b>					
	OS 8051 VSE	SOVE	SLIP ON	YES	TP-OV70
	OS 8051 VSEB	XOVE	SLIP ON	YES	TP-OV70
<b>GSX 600 F 88-97 (GN72A)</b>					
	OS 8043 VSE	SOVE	SLIP ON (2 in 1)	YES	TP-OV70
<b>GSX 600 F 98-05 (AJ)</b>					
	OS 8047 VSE	SOVE	SLIP ON	YES	TP-OV70
	OS 8047 VSEB	XOVE	SLIP ON	YES	TP-OV70
<b>GSX 600 R SRAD 97-00 (AD)</b>					
	OS 8063 VSE	SOVE	SLIP ON	NO	TP-OV70
<b>GSX 600 R 01-05 (BG)</b>					
	OS 8067 VSE	SOVE	SLIP ON	YES	TP-OV70
	OS 8067 VSEB	XOVE	SLIP ON	YES	TP-OV70
<b>GSX 600 R 06-07 (CE1)</b>					
	OS 8068 VSE	SOVE	SLIP ON	NO	TP-OV70
<b>GSX 600 R 08-10 (CV1)</b>					
	OS 8069 VSE	SOVE	SLIP ON	NO	TP-OV70
	XS 8369 V	L2X	SLIP ON	NO	NO
<b>GSX 600 R 11-15</b>					
	OS 8064 VSE	SOVE	SLIP ON	NO	TP-OV70
	XS 8364 V	L2X	SLIP ON	NO	NO





















REFERENCE	RANGE	EXHAUST TYPE	CE	INSIDE
<b>SV 650 / SV 650 S 99-03 (AV) (AY*)</b>				
 OS 8049 VSE	SOVE	SLIP ON	YES	TP-OV70
<b>SV 650 / S 04-05 (WVBY)</b>				
 OS 8254 VSE	SOVE	SLIP ON	YES	TP-OV70
 OS 8254 VSEB	XOVE	SLIP ON	YES	TP-OV70
<b>SV 650 S 06-12</b>				
 OS 8056 VSE	SOVE	SLIP ON	YES	TP-OV70
 OS 8056 VSEB	XOVE	SLIP ON	YES	TP-OV70
<b>SV 650 S 16-19 (WCX0)</b>				
 OS 8033 VSE	SOVE	SLIP ON	YES	TP-OV70
 OS 8033 VSEB	XOVE	SLIP ON	YES	TP-OV70
 XS 8333 XB	L3XB	SLIP ON	YES	TP-HP4
<b>SV 650 X 16-19 (WCX1)</b>				
 OS 8033 VSE	SOVE	SLIP ON	YES	TP-OV70
 OS 8033 VSEB	XOVE	SLIP ON	YES	TP-OV70
 XS 8333 XB	L3XB	SLIP ON	YES	TP-HP4
<b>SFV 650 GLADIUS 09-15 (WVCX)</b>				
 FS 8858 SS	X55S	SLIP ON	YES	TP-X55SS
 OS 8058 VSE	SOVE	SLIP ON	YES	TP-OV70
 XS 8358 V	L2X	SLIP ON	YES	NO
<b>GSF 650 N / S BANDIT 07-15 (WVCZ)</b>				
 OS 8057 VSE	SOVE	SLIP ON	YES	TP-OV70
 OS 8057 VSEB	XOVE	SLIP ON	YES	TP-OV70
 XS 8357 XB	L3XB	SLIP ON	YES	TP-HP4
<b>GSX 650 F 08-15 (WVCJ)</b>				
 OS 8057 VSE	SOVE	SLIP ON	YES	TP-OV70
 OS 8057 VSEB	XOVE	SLIP ON	YES	TP-OV70
 XS 8357 XB	L3XB	SLIP ON	YES	TP-HP4
<b>V-STROM 650 04-16</b>				
 OS 8059 VSE	SOVE	FULL SYSTEM	NO	TP-OV70
<b>V-STROM DL 650 17-19</b>				
 ES 8052 SS	MXT	SLIP ON	NO	TP-MXT80
<b>GSR 750 11-16 (C5)</b>				
 FS 8862 SS	X55S	SLIP ON	YES	TP-X55SS





















REFERENCE	RANGE	EXHAUST TYPE	CE	INSIDE
 OS 8062 VSE	SOVE	SLIP ON	YES	TP-OV70
 OS 8062 VSEB	XOVE	SLIP ON	YES	TP-OV70
 OS 8062 VTI	VTI	SLIP ON	YES	TP-OV3
 OS 862 RRB	RC1B	SLIP ON	YES	TP-OVC12
 XS 8362 XB	L3XB	SLIP ON	YES	TP-HP4
<b>GSX-S 750 17-19 (C5)</b>				
 FS 8862 SS	X55S	SLIP ON	YES	TP-X55SS
 OS 8062 VSE	SOVE	SLIP ON	YES	TP-OV70
 OS 8062 VSEB	XOVE	SLIP ON	YES	TP-OV70
 OS 8062 VTI	VTI	SLIP ON	YES	TP-OV3
 OS 862 RRB	RC1B	SLIP ON	YES	TP-OVC12
 XS 8362 XB	L3XB	SLIP ON	YES	TP-HP4
<b>GSX 750 NAKED 97-03 (AE)</b>				
 OS 8065 VSE	SOVE	SLIP ON	YES	TP-OV70
<b>GSX 750 F 88-97 (GR78A)</b>				
 OS 8043 VSE	SOVE	SLIP ON (2 in 1)	YES	TP-OV70
<b>GSX 750 F 98-05 (AK)</b>				
 OS 8047 VSE	SOVE	SLIP ON	YES	TP-OV70
 OS 8047 VSEB	XOVE	SLIP ON	YES	TP-OV70
<b>GSX 750 R 90-91 (GR7AD)</b>				
 OS 8060 VSE	SOVE	SLIP ON	NO	TP-OV70
<b>GSX 750 RW 92-95 (GR7BD)</b>				
 OS 8061 VSE	SOVE	SLIP ON (2 in 1)	YES	TP-OV70
<b>GSX 750 R SRAD 96-99 (GR7DD)</b>				
 OS 8063 VSE	SOVE	SLIP ON	NO	TP-OV70
<b>GSX 750 R 00-05 (BD)</b>				
 OS 8067 VSE	SOVE	SLIP ON	YES	TP-OV70
 OS 8067 VSEB	XOVE	SLIP ON	YES	TP-OV70
<b>GSX 750 R 06-07 (CF)</b>				
 OS 8068 VSE	SOVE	SLIP ON	NO	TP-OV70
<b>GSX 750 R 08-10 (CW1)</b>				
 OS 8069 VSE	SOVE	SLIP ON	NO	TP-OV70
 XS 8369 V	L2X	SLIP ON	NO	NO



REFERENCE	RANGE	EXHAUST TYPE	CE	INSIDE
<b>GSX 750 R 11-15</b>				
 OS 8064 VSE	SOVE	SLIP ON	NO	TP-OV70
 XS 8364 V	L2X	SLIP ON	NO	NO
<b>RF 900 R (GT73D)</b>				
 OS 8081 VSE	SOVE	SLIP ON	YES	TP-OV70
<b>SV1000S / SV1000N 03-05 (BX)</b>				
 OS 8078 VSE	SOVE	SLIP ON (RIGHT MUFFLER)	YES	TP-OV70
 OS 8078 VSEB	XOVE	SLIP ON (RIGHT MUFFLER)	YES	TP-OV70
 OS 8079 VSE	SOVE	SLIP ON (LEFT MUFFLER)	YES	TP-OV70
 OS 8079 VSEB	XOVE	SLIP ON (LEFT MUFFLER)	YES	TP-OV70
<b>TL1000S 97-01 (AG)</b>				
 OS 8088 VSE	SOVE	SLIP ON (RIGHT MUFFLER)	NO	TP-OV70
 OS 8089 VSE	SOVE	SLIP ON (LEFT MUFFLER)	NO	TP-OV70
<b>DL 1000 V-STROM 02-13</b>				
 OS 8070 VSE	SOVE	SLIP ON (RIGHT MUFFLER)	NO	TP-OV70
 OS 8071 VSE	SOVE	SLIP ON (LEFT MUFFLER)	NO	TP-OV70
<b>DL 1000 V-STROM 14-19</b>				
 ES 8084 SS	MXT	SLIP ON	YES	TP-MXT80
<b>GSX 1000 R 01-04 (WVBL)</b>				
 OS 8098 VSE	SOVE	SLIP ON	YES	TP-OV70
<b>GSX 1000 R 05-06 (B6)</b>				
 OS 8094 VSE	SOVE	SLIP ON	NO	TP-OV70
<b>GSX 1000 R 07-08 (WVCL)</b>				
 OS 8176 VSE	SOVE	SLIP ON (RIGHT SIDE ONLY)	NO	TP-OV70
<b>GSX 1000 R 09-11 (WVCL)</b>				
 OS 8175 VSE	SOVE	SLIP ON (RIGHT SIDE ONLY)	NO	TP-OV70
<b>GSX 1000 R 12-13</b>				
 OS 8080 VSE	SOVE	SLIP ON	NO	TP-OV70
<b>GSX 1000 R 17-19</b>				
 CS 8282 RC	RC	SLIP ON	NO	NO
 OS 882 RRB	RC1B	SLIP ON	NO	TP-OVC12
<b>GSX 1000 S / F 15-16</b>				
 CS 8299 RC	RC	SLIP ON	NO	TP-OV3
 SS 8799 C	SX1	FULL SYSTEM	YES	TP-OV6
 XS 8399 V	L2X	SLIP ON	YES	NO

REFERENCE	RANGE	EXHAUST TYPE	CE	INSIDE
<b>KATANA 1000 19-20</b>				
 CS 8299 RC	RC	SLIP ON	NO	TP-OV3
 SS 8799 C	SX1	FULL SYSTEM	NO	TP-OV6
 XS 8399 V	L2X	SLIP ON	NO	NO
<b>GSX 1200 INAZUMA 99-03 (A3)</b>				
 OS 8093 VSE	SOVE	SLIP ON	NO	TP-OV70
<b>GSF 1200 N BANDIT 96-99 (GV75A)</b>				
 OS 8085 VSE	SOVE	SLIP ON	YES	TP-OV70
 OS 8085 VSEB	XOVE	SLIP ON	YES	TP-OV70
<b>GSF 1200 N BANDIT 00-05 (WVA9)</b>				
 OS 8095 VSE	SOVE	SLIP ON	YES	TP-OV70
 OS 8095 VSEB	XOVE	SLIP ON	YES	TP-OV70
<b>GSF 1250 N BANDIT 07-15 (CH)</b>				
 OS 8092 VSE	SOVE	SLIP ON	YES	TP-OV70
 OS 8092 VSEB	XOVE	SLIP ON	YES	TP-OV70
 XS 8357 XB	L3XB	SLIP ON	YES	TP-HP4
<b>GSX 1250 N 10-15</b>				
 OS 8092 VSE	SOVE	SLIP ON	YES	TP-OV70
 OS 8092 VSEB	XOVE	SLIP ON	YES	TP-OV70
 XS 8357 XB	L3XB	SLIP ON	YES	TP-HP4
<b>GSX 1300 R HAYABUSA 99-07 (WVA1)</b>				
 OS 8090 VSE	SOVE	SLIP ON (RIGHT MUFFLER)	YES	TP-OV70
 OS 8090 VSEB	XOVE	SLIP ON (RIGHT MUFFLER)	YES	TP-OV70
 OS 8091 VSE	SOVE	SLIP ON (LEFT MUFFLER)	YES	TP-OV70
 OS 8091 VSEB	XOVE	SLIP ON (LEFT MUFFLER)	YES	TP-OV70
<b>GSX 1300 R HAYABUSA 08-16 (WVCK)</b>				
 OS 8072 VSE	SOVE	SLIP ON (RIGHT MUFFLER)	NO	TP-OV70
 OS 8073 VSE	SOVE	SLIP ON (LEFT MUFFLER)	NO	TP-OV70
<b>GSX 1400 NAKED 01-04 (WVBN)</b>				
 OS 8096 VSE	SOVE	SLIP ON (RIGHT MUFFLER)	NO	TP-OV70
 OS 8097 VSE	SOVE	SLIP ON (LEFT MUFFLER)	NO	TP-OV70
<b>SYM</b>				
<b>JET 50</b>				
 K 304	SCCL	FULL SYSTEM	NO	NO







REFERENCE	RANGE	EXHAUST TYPE	CE	INSIDE
<b>JUNGLE 50</b>				
 K 304	SCCL	FULL SYSTEM	NO	NO
<b>SUPERFANCY 50</b>				
 K 304	SCCL	FULL SYSTEM	NO	NO
<b>TRIUMPH</b>				
<b>TT 600 00-02 (TH)</b>				
 OT 4041 VSE	SOVE	BOLT ON	YES	TP-OV70
<b>DAYTONA 600 03-04</b>				
 OT 4041 VSE	SOVE	BOLT ON	NO	TP-OV70
<b>SPEEDFOUR 02-05</b>				
 OT 4041 VSE	SOVE	BOLT ON	NO	TP-OV70
<b>DAYTONA 650 05</b>				
 OT 4041 VSE	SOVE	BOLT ON	NO	TP-OV70
<b>STREET TRIPLE 675 07-11 (D67LD)</b>				
 OT 4044 VSE	SOVE	SLIP ON (RIGHT MUFFLER)	NO	TP-OV70
 OT 4045 VSE	SOVE	SLIP ON (LEFT MUFFLER)	NO	TP-OV70
<b>STREET TRIPLE 675 13-16</b>				
 FT 4846 SSB	X55SB	SLIP ON	NO	TP-X55SS
<b>TRIDENT 750/900 &lt;99</b>				
 OT 4084 VSE	SOVE	SLIP ON (RIGHT MUFFLER)	NO	TP-OV70
 OT 4085 VSE	SOVE	SLIP ON (LEFT MUFFLER)	NO	TP-OV70
<b>SPRINT &lt;99</b>				
 OT 4084 VSE	SOVE	SLIP ON (RIGHT MUFFLER)	NO	TP-OV70
 OT 4085 VSE	SOVE	SLIP ON (LEFT MUFFLER)	NO	TP-OV70
<b>TROPHY &lt;96</b>				
 OT 4084 VSE	SOVE	SLIP ON (RIGHT MUFFLER)	NO	TP-OV70
 OT 4085 VSE	SOVE	SLIP ON (LEFT MUFFLER)	NO	TP-OV70
<b>DAYTONA T357</b>				
 OT 4084 VSE	SOVE	SLIP ON (RIGHT MUFFLER)	NO	TP-OV70
 OT 4085 VSE	SOVE	SLIP ON (LEFT MUFFLER)	NO	TP-OV70
<b>TIGER 800 - 800 XC 11-13 (A08)</b>				
 OT 4048 VSE	SOVE	SLIP ON	YES	TP-OV70
<b>TIGER 800 16-19</b>				
 ET 4065 SS	MXT	SLIP ON	NO	TP-MXT80
<b>BONNEVILLE / T100</b>				
 OT 476 SSS	OVC11SS	SLIP ON (RIGHT MUFFLER)	NO	TP-OV3

REFERENCE	RANGE	EXHAUST TYPE	CE	INSIDE
 OT 477 SSS	OVC11SS	SLIP ON (LEFT MUFFLER)	NO	TP-OV3
<b>BONNEVILLE NEWCHURCH / SE 15-16</b>				
 OT 464 SS	OVC11SS	SLIP ON (RIGHT MUFFLER)	NO	TP-OV3
 OT 464 SSB	OVC11SB	SLIP ON (RIGHT MUFFLER)	NO	TP-OV3
 OT 465 SS	OVC11SS	SLIP ON (LEFT MUFFLER)	NO	TP-OV3
 OT 465 SSB	OVC11SB	SLIP ON (LEFT MUFFLER)	NO	TP-OV3
<b>THRUXTON 865 04-15</b>				
 OT 470 SSS	OVC11SS	SLIP ON (RIGHT MUFFLER)	NO	TP-OV3
 OT 471 SSS	OVC11SS	SLIP ON (LEFT MUFFLER)	NO	TP-OV3
<b>STREET TWIN 16-18</b>				
 OT 460 SS	OVC11SS	SLIP ON (RIGHT MUFFLER)	YES	TP-OV3
 OT 461 SS	OVC11SS	SLIP ON (LEFT MUFFLER)	YES	TP-OV3
<b>T 955 i SPEED TRIPLE / DAYTONA 98-01 (TE)</b>				
 OT 4081 VSE	SOVE	SLIP ON	YES	TP-OV70
<b>ST1050 SPEED TRIPLE 05-06 (515NJ)</b>				
 OT 4088 VSE	SOVE	SLIP ON (RIGHT MUFFLER)	NO	TP-OV70
 OT 4089 VSE	SOVE	SLIP ON (LEFT MUFFLER)	NO	TP-OV70
 OT 4388 VSE	SOVE	SLIP ON (LOW MOUNT)	NO	TP-OV70
<b>ST1050 SPEED TRIPLE 07-10</b>				
 OT 4088 VSE	SOVE	SLIP ON (RIGHT MUFFLER)	NO	TP-OV70
 OT 4089 VSE	SOVE	SLIP ON (LEFT MUFFLER)	NO	TP-OV70
<b>ST1050 SPEED TRIPLE 11-13 (515NV)</b>				
 OT 4090 VSE	SOVE	SLIP ON (RIGHT MUFFLER)	YES	TP-OV70
 OT 4091 VSE	SOVE	SLIP ON (LEFT MUFFLER)	YES	TP-OV70
 OT 4390 VSE	SOVE	SLIP ON (LOW MOUNT)	NO	TP-OV70
<b>BONNEVILLE / T120 2016</b>				
 OT 462 SS	OVC11SS	SLIP ON (RIGHT MUFFLER)	YES	TP-OV3
 OT 463 SS	OVC11SS	SLIP ON (LEFT MUFFLER)	YES	TP-OV3
<b>BOBBER 17-19</b>				
 OT 4068 SS	HC1-3S	SLIP ON (RIGHT MUFFLER)	NO	TP-OV3
 OT 4068 SSB	HC1-3SB	SLIP ON (RIGHT MUFFLER)	NO	TP-OV3
 OT 4069 SS	HC1-3S	SLIP ON (LEFT MUFFLER)	NO	TP-OV3
 OT 4069 SSB	HC1-3SB	SLIP ON (LEFT MUFFLER)	NO	TP-OV3



REFERENCE	RANGE	EXHAUST TYPE	CE	INSIDE
-----------	-------	--------------	----	--------

### SPEEDMASTER 18-19

	OT 4068 SS	HC1-3S	SLIP ON (RIGHT MUFFLER)	NO	TP-OV3
	OT 4068 SSB	HC1-3SB	SLIP ON (RIGHT MUFFLER)	NO	TP-OV3
	OT 4069 SS	HC1-3S	SLIP ON (LEFT MUFFLER)	NO	TP-OV3
	OT 4069 SSB	HC1-3SB	SLIP ON (LEFT MUFFLER)	NO	TP-OV3

### THRUXTON 1200 16-19

	OT 464 SS	OVC11SS	SLIP ON (RIGHT MUFFLER)	YES	TP-OV3
	OT 464 SSB	OVC11SB	SLIP ON (RIGHT MUFFLER)	YES	TP-OV3
	OT 465 SS	OVC11SS	SLIP ON (LEFT MUFFLER)	YES	TP-OV3
	OT 465 SSB	OVC11SB	SLIP ON (LEFT MUFFLER)	YES	TP-OV3

### TIGER 1200 12-19

	ET 4092 SS	MXT	SLIP ON	NO	TP-MXT80
---	------------	-----	---------	----	----------

### VESPA

#### T-5





	V 277	ORIGINAL	FULL SYSTEM	NO	NO
---	-------	----------	-------------	----	----

#### GTS 300

	XP 0161 XS	L5X	SLIP ON	NO	NO
--	------------	-----	---------	----	----

### VICTORY

#### VEGAS / HAMMER 06-16

	HV 3001 SB	HC1-2B	SLIP ON (UPPER MUFFLER)	NO	TP-OV3
	HV 3001 SC	HC1-2C	SLIP ON (UPPER MUFFLER)	NO	TP-OV3
	HV 3002 SB	HC1-2B	SLIP ON (LOWER MUFFLER)	NO	TP-OV3
	HV 3002 SC	HC1-2C	SLIP ON (LOWER MUFFLER)	NO	TP-OV3

### VOGE

#### 300 AC

	CV 1221 RC	RC	SLIP ON	NO	TP-OV3
---	------------	----	---------	----	--------

#### 500 R

	CV 1220 RC	RC	SLIP ON	NO	TP-OV3
---	------------	----	---------	----	--------

### YAMAHA

#### WHY - MINARELLI HORIZONTAL

	YAM 2326	SCCL	FULL SYSTEM	NO	NO
---	----------	------	-------------	----	----

#### ZEST 50-90 - MINARELLI HORIZONTAL

	YAM 2326	SCCL	FULL SYSTEM	NO	NO
---	----------	------	-------------	----	----

#### ZUMA II - MINARELLI VERTICAL

	YAM 2334	SCCL	FULL SYSTEM	NO	NO
---	----------	------	-------------	----	----

### JOG 50 (3WG) - MINARELLI HORIZONTAL

	YAM 2326	SCCL	FULL SYSTEM	YES	NO
---	----------	------	-------------	-----	----

### NEO'S - MINARELLI HORIZONTAL

	YAM 2326	SCCL	FULL SYSTEM	NO	NO
---	----------	------	-------------	----	----

### SLIDER 50 - MINARELLI VERTICAL

	YAM 2334	SCCL	FULL SYSTEM	NO	NO
---	----------	------	-------------	----	----

### SPY 50 - MINARELLI VERTICAL

	YAM 2334	SCCL	FULL SYSTEM	NO	NO
---	----------	------	-------------	----	----

### AEROX - MINARELLI HORIZONTAL

	YAM 2326	SCCL	FULL SYSTEM	NO	NO
---	----------	------	-------------	----	----

### BREEZE - MINARELLI HORIZONTAL

	YAM 2326	SCCL	FULL SYSTEM	NO	NO
---	----------	------	-------------	----	----

### BUMP I / II 50 - MINARELLI VERTICAL

	YAM 2334	SCCL	FULL SYSTEM	NO	NO
---	----------	------	-------------	----	----

### BW'S 50 - MINARELLI VERTICAL

	YAM 2334	SCCL	FULL SYSTEM	NO	NO
---	----------	------	-------------	----	----

### BW'S 65 NEXT GENERATION - MINARELLI VERT.

	YAM 2334	SCCL	FULL SYSTEM	NO	NO
---	----------	------	-------------	----	----

### JOG 90 - MINARELLI HORIZONTAL

	YAM 2326	SCCL	FULL SYSTEM	NO	NO
---	----------	------	-------------	----	----

### YBR 125

	OY 9003 VSE	SOVE	FULL SYSTEM	NO	TP-OV70
---	-------------	------	-------------	----	---------

### YZF 125 R 08-13 (RE06)

	OY 9009 VSE	SOVE	FULL SYSTEM	NO	TP-OV70
---	-------------	------	-------------	----	---------

### MT 125 14-15

	OY 9008 VSE	SOVE	FULL SYSTEM	NO	TP-OV70
---	-------------	------	-------------	----	---------

### WR 125 R / X 09-16 (DE07)

	DKAT KIT 9014 C1	DKAT	DKAT - FULL COLECTOR	NO	NO
---	------------------	------	----------------------	----	----

	OY 9014 VSE	SOVE	SLIP ON	YES	TP-OV70
---	-------------	------	---------	-----	---------

	OY 9014 VSEB	XOVE	SLIP ON	YES	TP-OV70
---	--------------	------	---------	-----	---------

### YBR 250 12-13

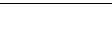
	OY 920 S	2-CON	FULL SYSTEM	NO	TP-OV3
---	----------	-------	-------------	----	--------























### R3 15-19 (R25)

























	CY 9225 RC	RC	FULL SYSTEM	NO	
---	------------	----	-------------	----	--

	OY 9025 VSE	SOVE	FULL SYSTEM	NO	TP-OV70
---	-------------	------	-------------	----	---------



























	OY 9025 VTI	VTI	FULL SYSTEM	NO	TP-OV3
---	-------------	-----	-------------	----	--------















REFERENCE	RANGE	EXHAUST TYPE	CE	INSIDE
<b>MT-03 15-19</b>				
 CY 9225 RC	RC	FULL SYSTEM	NO	
 OY 9025 VSE	SOVE	FULL SYSTEM	NO	TP-OV70
 OY 9025 VTI	VTI	FULL SYSTEM	NO	TP-OV3
<b>T-MAX DX / SX 17-18 (SJ14)</b>				
 XY 2397 XS	L5X	FULL SYSTEM	YES	TP-OV3
<b>XJ 600 N DIVERSION (RJ01)</b>				
 OY 9045 VSE	SOVE	SLIP ON (2 in 1)	YES	TP-OV70
<b>XJ-6 09-15 (RJ19) (RJ22*)</b>				
 OY 9555 VSE	SOVE	FULL SYSTEM	YES	TP-OV70
 SY 9755 C	SX1	FULL SYSTEM	YES	TP-OV6
<b>FZS 600 FAZER 98-03 (RJ02)</b>				
 OY 9063 VSE	SOVE	SLIP ON	YES	TP-OV70
<b>FZR 600 R 94-95 (4JHS)</b>				
 OY 9043 VSE	SOVE	SLIP ON	YES	TP-OV70
<b>YZF 600 THUNDERCAT (4TV) (4CV*,4WE*)</b>				
 OY 9049 VSE	SOVE	SLIP ON	YES	TP-OV70
<b>YZF 600 R-6 99-02 (RJ03)</b>				
 OY 9051 VSE	SOVE	SLIP ON	YES	TP-OV70
<b>YZF 600 R-6 03-08 (RJ05)</b>				
 OY 9053 VSE	SOVE	SLIP ON	YES	TP-OV70
 OY 9053 VSEB	XOVE	SLIP ON	YES	TP-OV70
<b>YZF 600 R-6R 06-15 (RJ11)</b>				
 OY 9154 VSE	SOVE	SLIP ON	YES	TP-OV70
<b>MT-07 14-16 (RM04)</b>				
 CY 9162 RC	RC	FULL SYSTEM	YES	NO
 OY 962 RRB	RC1B	FULL SYSTEM	YES	TP-OVC12
 SY 9762 C	SX1	FULL SYSTEM	YES	TP-OV6
 XY 9362 XB	L3XB	FULL SYSTEM	YES	TP-HP4
<b>MT-07 17-19 (RM17,RM18)</b>				
 CY 9162 RC	RC	FULL SYSTEM	YES	NO
 OY 962 RRB	RC1B	FULL SYSTEM	YES	TP-OVC12
 SY 9762 C	SX1	FULL SYSTEM	YES	TP-OV6
 XY 9362 XB	L3XB	FULL SYSTEM	YES	TP-HP4





REFERENCE	RANGE	EXHAUST TYPE	CE	INSIDE
<b>TRACER 700 17-19 (RM14,RM15)</b>				
 CY 9162 RC	RC	FULL SYSTEM	YES	NO
 OY 959 RRB	RC1B	FULL SYSTEM	YES	TP-OVC12
 SY 9762 C	SX1	FULL SYSTEM	YES	TP-OV6
 XY 9362 XB	L3XB	FULL SYSTEM	YES	TP-HP4
<b>XSR 700 16-19 (RM11,RM12)</b>				
 CY 9162 RC	RC	FULL SYSTEM	YES	NO
 OY 960 RRB	RC1B	FULL SYSTEM	YES	TP-OVC12
 OY 962 SS	OVC13	FULL SYSTEM	NO	TP-OV3
 SY 9762 C	SX1	FULL SYSTEM	YES	TP-OV6
 XY 9362 XB	L3XB	FULL SYSTEM	YES	TP-HP4
<b>YZF 750 R (4HDS)</b>				
 OY 9061 VSE	SOVE	SLIP ON	YES	TP-OV70
<b>FZ-8 10-16 (RN25)</b>				
 OY 9088 VSE	SOVE	SLIP ON	YES	TP-OV70
 XY 9388 XB	L3XB	SLIP ON	YES	TP-HP4
<b>TDM 850 (3VD,4TX)</b>				
 OY 9092 VSE	SOVE	SLIP ON (RIGHT MUFFLER)	NO	TP-OV70
 OY 9093 VSE	SOVE	SLIP ON (LEFT MUFFLER)	NO	TP-OV70
<b>TRX 850 97-00 (4UN)</b>				
 OY 9076 VSE	SOVE	SLIP ON (RIGHT MUFFLER)	NO	TP-OV70
 OY 9077 VSE	SOVE	SLIP ON (LEFT MUFFLER)	NO	TP-OV70
<b>MT-09 13-16 (RN29)</b>				
 CY 9180 RC	RC	FULL SYSTEM	YES	NO
 FY 9880 SSB	X55SB	FULL SYSTEM	YES	TP-X55SS
 OY 9580 VSE	SOVE	FULL SYSTEM	YES	TP-OV70
 OY 9580 VSEB	XOVE	FULL SYSTEM	YES	TP-OV70
 OY 980 RRB	RC1B	FULL SYSTEM	YES	TP-OVC12
 SY 9780 C	SX1	FULL SYSTEM	YES	TP-OV6
 XY 9380 XB	L3XB	FULL SYSTEM	YES	TP-HP4
<b>MT-09 17-19 (RN43)</b>				
 CY 9180 RC	RC	FULL SYSTEM	YES	NO
 OY 9580 VSE	SOVE	FULL SYSTEM	YES	TP-OV70



	REFERENCE	RANGE	EXHAUST TYPE	CE	INSIDE
	OY 9580 VSEB	XOVE	FULL SYSTEM	YES	TP-OV70
	OY 980 RRB	RC1B	FULL SYSTEM	YES	TP-OVC12
	SY 9780 C	SX1	FULL SYSTEM	YES	TP-OV6
	XY 9380 XB	L3XB	FULL SYSTEM	YES	TP-HP4
<b>TRACER 900 13-16</b>					
	CY 9180 RC	RC	FULL SYSTEM	YES	NO
	FY 9880 SSB	X55SB	FULL SYSTEM	YES	TP-X55SS
	OY 9580 VSE	SOVE	FULL SYSTEM	YES	TP-OV70
	OY 9580 VSEB	XOVE	FULL SYSTEM	YES	TP-OV70
	OY 979 RRB	RC1B	FULL SYSTEM	YES	TP-OVC12
	XY 9380 XB	L3XB	FULL SYSTEM	YES	TP-HP4
<b>TRACER 900 17-19 (RN43)</b>					
	CY 9180 RC	RC	FULL SYSTEM	YES	NO
	OY 9580 VSE	SOVE	FULL SYSTEM	YES	TP-OV70
	OY 9580 VSEB	XOVE	FULL SYSTEM	YES	TP-OV70
	OY 979 RRB	RC1B	FULL SYSTEM	YES	TP-OVC12
	XY 9380 XB	L3XB	FULL SYSTEM	YES	TP-HP4
<b>XSR 900 16-19 (RN43)</b>					
	CY 9180 RC	RC	FULL SYSTEM	YES	NO
	OY 9580 VSE	SOVE	FULL SYSTEM	YES	TP-OV70
	OY 9580 VSEB	XOVE	FULL SYSTEM	YES	TP-OV70
	OY 980 RRB	RC1B	FULL SYSTEM	YES	TP-OVC12
	OY 980 SS	OVC13	FULL SYSTEM	NO	TP-OV3
	SY 9780 C	SX1	FULL SYSTEM	YES	TP-OV6
	XY 9380 XB	L3XB	FULL SYSTEM	YES	TP-HP4
<b>TDM 900 (RN08)</b>					
	OY 9078 VSE	SOVE	SLIP ON (RIGHT MUFFLER)	YES	TP-OV70
	OY 9079 VSE	SOVE	SLIP ON (LEFT MUFFLER)	YES	TP-OV70
<b>FZS 1000 FAZER 00-05 (RN06)</b>					
	OY 9089 VSE	SOVE	SLIP ON	YES	TP-OV70
<b>FZ-1 06-14 (RN16)</b>					
	OY 9090 VSE	SOVE	SLIP ON	YES	TP-OV70

	REFERENCE	RANGE	EXHAUST TYPE	CE	INSIDE
<b>FZR 1000 EXUP (3GMS)</b>					
	OY 9081 VSE	SOVE	SLIP ON	YES	TP-OV70
	OY 9081 VSEB	XOVE	SLIP ON	YES	TP-OV70
<b>YZF 1000 THUNDERICE (45V)</b>					
	OY 9085 VSE	SOVE	BOLT ON	YES	TP-OV70
	OY 9085 VSEB	XOVE	BOLT ON	YES	TP-OV70
<b>YZF 1000 R-1 98-01 (RN01)</b>					
	OY 9087 VSE	SOVE	SLIP ON	YES	TP-OV70
<b>YZF 1000 R-1 02-03 (RN09)</b>					
	OY 9097 VSE	SOVE	SLIP ON	YES	TP-OV70
<b>YZF 1000 R-1 16-19</b>					
	CY 9286 RC	RC	SLIP ON	NO	NO
	OY 986 RRB	RC1B	SLIP ON	NO	TP-OVC12
<b>MT-10 16-18 (RN45)</b>					
	FY 9874 SSB	X55SB	SLIP ON	YES	TP-X55SS
	OY 974 RR	RC1	SLIP ON	YES	TP-OVC12
<b>BT 1100 BULLDOG (RP05)</b>					
	OY 9094 VSE	SOVE	SLIP ON (RIGHT MUFFLER)	YES	TP-OV70
	OY 9095 VSE	SOVE	SLIP ON (LEFT MUFFLER)	YES	TP-OV70





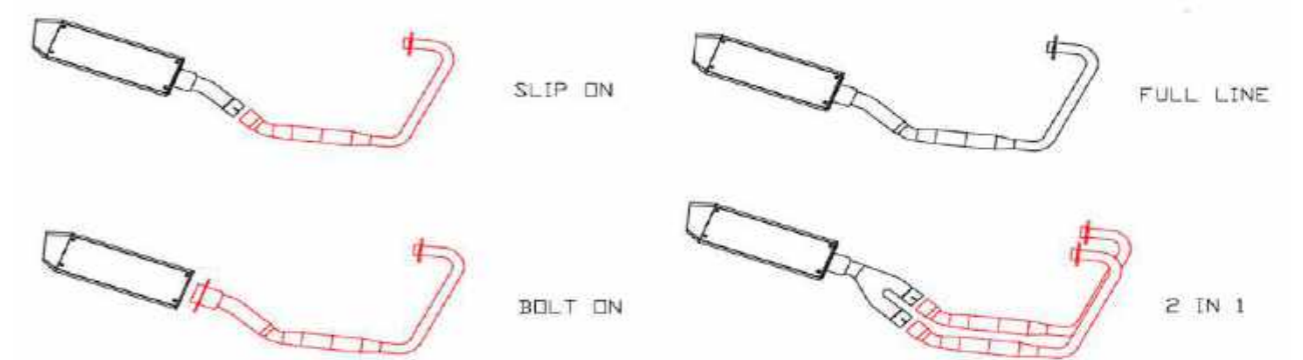



















**ZONTES**

<b>X-310</b>					
	CZ 3290 RC	RC	FULL SYSTEM	NO	TP-OV3
<b>R-310</b>					
	CZ 3290 RC	RC	FULL SYSTEM	NO	TP-OV3
<b>T-310</b>					
	CZ 3290 RC	RC	FULL SYSTEM	NO	TP-OV3
<b>V-310</b>					
	SZ 3791 C	SX1	FULL SYSTEM	NO	TP-OV6





REFERENCE	RANGE	EXHAUST TYPE	CE	INSIDE
<b>zz DB-KILLER</b>				
<b>DB-KILLER</b>				
	OV10-4	DB-KILLER	DB-KILLER	-
	OV15-4	DB-KILLER	DB-KILLER	-
	OV17-4	DB-KILLER	DB-KILLER	-
	OV17-9	DB-KILLER	DB-KILLER	-
	OV27-10	DB-KILLER	DB-KILLER	-
	OV27-9	DB-KILLER	DB-KILLER	-
	OV33-4	DB-KILLER	DB-KILLER	-
	OV33-TMAX	DB-KILLER	DB-KILLER	-
	OV80-10	DB-KILLER	DB-KILLER	-
	TP-10	DB-KILLER	DB-KILLER	-
	TP-11	DB-KILLER	DB-KILLER	-
	TP-12	DB-KILLER	DB-KILLER	-
	TP-15 (TP-OV10)	DB-KILLER	DB-KILLER	-
	TP-HP2	DB-KILLER	DB-KILLER	-
	TP-HP4	DB-KILLER	DB-KILLER	-
	TP-MXT80	DB-KILLER	DB-KILLER	-
	TP-OV	DB-KILLER	DB-KILLER	-
	TP-OV2	DB-KILLER	DB-KILLER	-
	TP-OV20	DB-KILLER	DB-KILLER	-
	TP-OV3	DB-KILLER	DB-KILLER	-
	TP-OV33	DB-KILLER	DB-KILLER	-
	TP-OV3L	DB-KILLER	DB-KILLER	-
	TP-OV6	DB-KILLER	DB-KILLER	-
	TP-OV70	DB-KILLER	DB-KILLER	-
	TP-OV72	DB-KILLER	DB-KILLER	-
	TP-OV74	DB-KILLER	DB-KILLER	-
	TP-OV77	DB-KILLER	DB-KILLER	-

REFERENCE	RANGE	EXHAUST TYPE	CE	INSIDE
	TP-OV8	DB-KILLER	DB-KILLER	-
	TP-OV9	DB-KILLER	DB-KILLER	-
	TP-X55SS	DB-KILLER	DB-KILLER	-
<b>zz IRONHEAD END CAPS</b>				
<b>IRONHEAD END CAPS</b>				
	HC1-60B	HC1-60B	SLASHED END CAP (BLACK)	-
	HC1-60C	HC1-60C	SLASHED END CAP (CHROME)	-
	HC1-62B	HC1-62B	BOTTLE END CAP (BLACK)	-
	HC1-62C	HC1-62C	BOTTLE END CAP (CHROME)	-
	HC1-63B	HC1-63B	SHORT GUN END CAP (BLACK)	-
	HC1-63C	HC1-63C	SHORT GUN END CAP (CHROME)	-
	HC1-65B	HC1-65B	CONICAL END CAP (BLACK)	-
	HC1-65C	HC1-65C	CONICAL END CAP (CHROME)	-
	HC1-66B	HC1-66B	FISHTAIL END CAP (BLACK)	-
	HC1-66C	HC1-66C	FISHTAIL END CAP (CHROME)	-
	HC2-60B	HC2-60B	SLASHED END CAP (BLACK)	-
	HC2-60C	HC2-60C	SLASHED END CAP (CHROME)	-
	HC2-61B	HC2-61B	SQUARE END CAP (BLACK)	-
	HC2-61C	HC2-61C	SQUARE END CAP (CHROME)	-
	HC2-66B	HC2-66B	FISHTAIL END CAP (BLACK)	-
	HC2-66C	HC2-66C	FISHTAIL END CAP (CHROME)	-
<b>zz IXIL WATERPROOF BAGS</b>				
<b>IXIL WATERPROOF BAGS</b>				
	BG013BK	BG013BK	WATERPROOF BAG 30 L. BLACK	-
	BG015BK	BG015BK	WATERPROOF BAG 50 L. BLACK	-
	BG016BK	BG016BK	WATERPROOF BAG 65 L. BLACK	-
	BG021BK	BG021BK	WATERPROOF BACKPACK 35 L. BLACK	-
	BG022BK	BG022BK	WATERPROOF BACKPACK 22 L. BLACK	-
	BG022GY	BG022GY	WATERPROOF BACKPACK 22 L. GREY	-























**IXIL head office**





P.I. CAN CUIÀS · ARQUITECTURA, 2  
08110 - MONTCADA I REIXAC  
BARCELONA · ESPAÑA

 34-93 565 06 60  
 34-93 565 06 61  
 [ixil@ixil.com](mailto:ixil@ixil.com)  
 [www.ixil.com](http://www.ixil.com)







REFERENCE	PRIX	GAMME	DESCRIPTION	CE	INTÉRIEUR
<b>APRILIA</b>					
<b>AMICO 50</b>					
 YAM 2334	125 €	SCCL	LIGNE COMPLÈTE	NON	NO
<b>RALLY 50</b>					
 YAM 2326	125 €	SCCL	LIGNE COMPLÈTE	NON	NO
<b>SCARABEO 50</b>					
 YAM 2326	125 €	SCCL	LIGNE COMPLÈTE	NON	NO
<b>SONIC 50 AIR/L.C.</b>					
 YAM 2326	125 €	SCCL	LIGNE COMPLÈTE	NON	NO
<b>SR 50 92-93</b>					
 YAM 2334	125 €	SCCL	LIGNE COMPLÈTE	NON	NO
<b>SR 50 00&gt; AIR/L.C. (RL)</b>					
 SZ 2822	125 €	SCCL	LIGNE COMPLÈTE	OUI	NO
<b>SR 50 WWW 94-99 AIR/L.C.</b>					
 YAM 2326	125 €	SCCL	LIGNE COMPLÈTE	NON	NO
<b>CR 125 / 150</b>					
 KIT 019 C1	155 €	DKAT	DKAT - COLECTEUR	NON	NO
 OA 619 RR	435 €	RC1	SILENCIEUX	NON	TP-OVC12
 XA 0319 V	369 €	L2X	SILENCIEUX	NON	NO
<b>RSV V4 1100</b>					
 CA 3285 RC	489 €	RC	SILENCIEUX	NON	NO
 OA 3085 VTR	735 €	VTI	SILENCIEUX	NON	NO
<b>TUONO V4 1100</b>					
 CA 3285 RC	489 €	RC	SILENCIEUX	NON	NO
 OA 3085 VTR	735 €	VTI	SILENCIEUX	NON	NO

REFERENCE	PRIX	GAMME	DESCRIPTION	CE	INTÉRIEUR
<b>ATALA</b>					
<b>CAROSSELLO 50</b>					
 YAM 2326	125 €	SCCL	LIGNE COMPLÈTE	NON	NO

REFERENCE	PRIX	GAMME	DESCRIPTION	CE	INTÉRIEUR
<b>BENELLI</b>					
<b>491 STRADA/GT/SP 50 AIR/L.C. - MINARELLI HORIZONTAL</b>					
 YAM 2326	125 €	SCCL	LIGNE COMPLÈTE	NON	NO
<b>K2 NAMUR 50 AIR/L.C. - MINARELLI HORIZONTAL</b>					
 YAM 2326	125 €	SCCL	LIGNE COMPLÈTE	NON	NO
<b>TNT 125 / T 125</b>					
 OB 506 SS	235 €	RCS	SILENCIEUX	NON	TP.OV3
 XB 5306 V	319 €	L2X	SILENCIEUX	NON	NO

REFERENCE	PRIX	GAMME	DESCRIPTION	CE	INTÉRIEUR
<b>LEONCINO 250</b>					
 OB 501 RR	875 €	RC1	LIGNE COMPLÈTE	NON	TP-OVC12
<b>TNT 250 / BN 251</b>					
 XB 5305 XB	449 €	L3XB	SILENCIEUX	NON	TP-HP4
<b>BJ 300 GS / BN 302</b>					
 XB 5303 XB	449 €	L3XB	SILENCIEUX	NON	TP-HP4
<b>BJ 300 GS-C / BN 302 R</b>					
 XB 5309 XB	449 €	L3XB	SILENCIEUX	NON	TP-HP4
<b>LEONCINO 500</b>					
 OB 551 RR	489 €	RC1	SILENCIEUX	NON	TP-OVC12
<b>TRK 502 16-19</b>					
 OB 535 RR	489 €	RC1	SILENCIEUX	NON	TP-OVC12
<b>BN 502 C '19</b>					
 OB 553 RR	489 €	RC1	SILENCIEUX	NON	TP-OVC12
<b>BN 752 S '19</b>					
 OB 552 RR	489 €	RC1	SILENCIEUX	NON	TP-OVC12
<b>BN 600 13 -14</b>					
 FB 5840 SS	679 €	X55S	DUAL SILENCIEUX (DROIT ET GAUCHE)	NON	TP-X55SS

REFERENCE	PRIX	GAMME	DESCRIPTION	CE	INTÉRIEUR
<b>BETA</b>					
<b>ARK 50 - MINARELLI HORIZONTAL</b>					
 YAM 2326	125 €	SCCL	LIGNE COMPLÈTE	NON	NO
<b>CHRONO 50 - MINARELLI HORIZONTAL</b>					
 YAM 2326	125 €	SCCL	LIGNE COMPLÈTE	NON	NO
<b>QUADRA 50 - MINARELLI HORIZONTAL</b>					
 YAM 2326	125 €	SCCL	LIGNE COMPLÈTE	NON	NO
<b>TEMPO 50 - MINARELLI HORIZONTAL</b>					
 YAM 2326	125 €	SCCL	LIGNE COMPLÈTE	NON	NO

REFERENCE	PRIX	GAMME	DESCRIPTION	CE	INTÉRIEUR
<b>BMW</b>					
<b>G 310 R 18-19</b>					
 OB 5029 VSE	569 €	SOVE	LIGNE COMPLÈTE	NON	TP-OV70
<b>C 600 SPORT 12-14</b>					
 OB 5091 VSE	415 €	SOVE	SILENCIEUX	NON	TP-OV70
<b>C 650 SPORT 16-19</b>					
 XB 5579 XS	559 €	L5X	SILENCIEUX	NON	NO
<b>G 650 X-COUNTRY 07-09 (EGSX)</b>					
 OB 5090 VSE	415 €	SOVE	SILENCIEUX	NON	TP-OV70
<b>G 650 X-CHALLENGE 07-09 (EGSX)</b>					
 OB 5090 VSE	415 €	SOVE	SILENCIEUX	NON	TP-OV70











REFERENCE	PRIX	GAMME	DESCRIPTION	CE	INTÉRIEUR
<b>G 650 X-MOTO 07-09 (EGSX)</b>					
 OB 5090 VSE	415 €	SOVE	SILENCIEUX	NON	TP-OV70
<b>F 650 GS 09-13 (E8GS)</b>					
 OB 5094 VSE	415 €	SOVE	SILENCIEUX	OUI	TP-OV70
<b>F 800 S 06-09</b>					
 OB 5092 VSE	415 €	SOVE	SILENCIEUX	NON	TP-OV70
<b>F 800 ST 06-09</b>					
 OB 5092 VSE	415 €	SOVE	SILENCIEUX	NON	TP-OV70
<b>F 800 R 09-15 (E8ST)</b>					
 OB 5094 VSE	415 €	SOVE	SILENCIEUX	OUI	TP-OV70
<b>F 800 GS 09-15 (E8GS)</b>					
 OB 5094 VSE	415 €	SOVE	SILENCIEUX	OUI	TP-OV70
<b>S 1000 XR 15-19</b>					
 OB 593 RR	435 €	RC1	SILENCIEUX	NON	TP-OVC12
<b>NINE T</b>					
 HB 5080 SB	679 €	HC1-3B	SILENCIEUX	NON	TP-OV3
 OB 580 SS	399 €	OVC13	SILENCIEUX	NON	TP-OV3
<b>R 1200 GS ADVENTURE 06-09</b>					
 OB 5098 VSE	415 €	SOVE	SILENCIEUX	NON	TP-OV70
<b>R 1200 GS 13-15 (R12W)</b>					
 OB 5097 VSE	415 €	SOVE	SILENCIEUX	OUI	TP-OV70
<b>R 1200 GS 16-17</b>					
 EB 5095 SS	565 €	MXT	SILENCIEUX	OUI	TP-MXT80
<b>R 1250 GS 18-19</b>					
 EB 5095 SS	565 €	MXT	SILENCIEUX	OUI	TP-MXT80
<b>CFMOTO</b>					
<b>NK 250</b>					
 OF 325 RRB	489 €	RC1B	LIGNE COMPLÈTE	NON	TP-OVC12S
<b>GT 400</b>					
 CF 3233 RC	489 €	RC	SILENCIEUX	NON	TP-OVC12
<b>NK 400</b>					
 CF 3230 RC	489 €	RC	SILENCIEUX	NON	TP-OVC12
<b>GT 650</b>					
 CF 3233 RC	489 €	RC	SILENCIEUX	NON	TP-OVC12
<b>NK 650</b>					
 CF 3230 RC	489 €	RC	SILENCIEUX	NON	TP-OVC12
<b>MT 650</b>					
 OF 331 RRB	489 €	RC1B	SILENCIEUX	NON	TP-OVC12

REFERENCE	PRIX	GAMME	DESCRIPTION	CE	INTÉRIEUR
<b>CPI</b>					
<b>CPI EURO II '04</b>					
 C 392	145 €	SCCL	LIGNE COMPLÈTE	OUI	NO
<b>DAELIM</b>					
<b>MESSAGE</b>					
 K 301	145 €	SCCL	LIGNE COMPLÈTE	NON	NO
<b>ROADWIN 125 (VJ125)</b>					
 OD 5011 VSE	345 €	SOVE	SILENCIEUX	NON	TP-OV70
 OD 5011 VSEB	375 €	XOVE	SILENCIEUX	NON	TP-OV70
<b>ROADWIN 125 R 07-15 (BA8)</b>					
 OD 5012 VSE	345 €	SOVE	SILENCIEUX	OUI	TP-OV70
 OD 5012 VSEB	375 €	XOVE	SILENCIEUX	OUI	TP-OV70
<b>ROADSPORT 125 R 07-15 (BA8)</b>					
 OD 5012 VSE	345 €	SOVE	SILENCIEUX	OUI	TP-OV70
 OD 5012 VSEB	375 €	XOVE	SILENCIEUX	OUI	TP-OV70
<b>ROADWIN 250 R 12-15</b>					
 OD 5012 VSE	345 €	SOVE	SILENCIEUX	NON	TP-OV70
 OD 5012 VSEB	375 €	XOVE	SILENCIEUX	NON	TP-OV70
<b>DERBI</b>					
<b>EASY - MINARELLI HORIZONTAL</b>					
 YAM 2326	125 €	SCCL	LIGNE COMPLÈTE	NON	NO
<b>VAMOS 50 - FRANCO MORINI</b>					
 SZ 2820	145 €	SCCL	LIGNE COMPLÈTE	NON	NO
<b>TERRA 125 ADVENTURE 10-12 (TS)</b>					
 OD 3307 VSE	415 €	SOVE	SILENCIEUX	OUI	TP-OV70
 OD 3307 VSEB	439 €	XOVE	SILENCIEUX	OUI	TP-OV70
<b>DRD 125 4T 10-12</b>					
 OD 3307 VSE	415 €	SOVE	SILENCIEUX	NON	TP-OV70
 OD 3307 VSEB	439 €	XOVE	SILENCIEUX	NON	TP-OV70
<b>DUCATI</b>					
<b>SCRAMBLER 400</b>					
 OD 549 RRB	465 €	RC1B	SILENCIEUX	NON	TP-OVC12
<b>M 696 MONSTER 08-13</b>					
 FD 5844 SS	345 €	X55S	SILENCIEUX (COTÉ DROIT)	NON	TP-X55SS
 FD 5845 SS	345 €	X55S	SILENCIEUX (COTÉ GAUCHE)	NON	TP-X55SS
<b>750 SS '98 (V2 750 SS)</b>					
 OD 5062 VSE	415 €	SOVE	SILENCIEUX (COTÉ DROIT)	OUI	TP-OV70





























	REFERENCE	PRIX	GAMME	DESCRIPTION	CE	INTÉRIEUR
	OD 5063 VSE	415 €	SOVE	SILENCIEUX (COTÉ GAUCHE)	OUI	TP-OV70
<b>SCRAMBLER 800</b>						
	OD 550 RRB	465 €	RC1B	SILENCIEUX	NON	TP-OVC12
<b>M 821 MONSTER</b>						
	FD 5848 S2	745 €	X55SP	SILENCIEUX	NON	TP-X55SS
<b>848 2008-2010</b>						
	OD 5084 VSE	415 €	SOVE	SILENCIEUX (COTÉ DROIT)	NON	TP-OV70
	OD 5085 VSE	415 €	SOVE	SILENCIEUX (COTÉ GAUCHE)	NON	TP-OV70
<b>939 SUPERSPORT 17-19</b>						
	SD 5110 C	355 €	SX1	SILENCIEUX	NON	TP-OV6
<b>1098 2007-2010</b>						
	OD 5084 VSE	415 €	SOVE	SILENCIEUX (COTÉ DROIT)	NON	TP-OV70
	OD 5085 VSE	415 €	SOVE	SILENCIEUX (COTÉ GAUCHE)	NON	TP-OV70
<b>1198 2008-2010</b>						
	OD 5084 VSE	415 €	SOVE	SILENCIEUX (COTÉ DROIT)	NON	TP-OV70
	OD 5085 VSE	415 €	SOVE	SILENCIEUX (COTÉ GAUCHE)	NON	TP-OV70

## GILERA





















<b>DNA 50</b>						
	V 280	125 €	SCCL	LIGNE COMPLÈTE	NON	NO
<b>EASY MOVING 50</b>						
	V 280	125 €	SCCL	LIGNE COMPLÈTE	NON	NO
<b>RUNNER 50</b>						
	V 280	125 €	SCCL	LIGNE COMPLÈTE	NON	NO
<b>SRK 50</b>						
	V 280	125 €	SCCL	LIGNE COMPLÈTE	NON	NO
<b>STALKER 50</b>						
	V 280	125 €	SCCL	LIGNE COMPLÈTE	NON	NO
<b>STORM 50</b>						
	V 280	125 €	SCCL	LIGNE COMPLÈTE	NON	NO
<b>GP 800 07-15</b>						
	OG 0528 VSE	415 €	SOVE	SILENCIEUX	NON	TP-OV70
	OG 0528 VSEB	439 €	XOVE	SILENCIEUX	NON	TP-OV70

## HARLEY DAVIDSON

<b>STREET 500 2014-2016</b>						
	HD 1001 SB	469 €	HC2-2B	SILENCIEUX	NON	TP-OV3
	HD 1001 SC	489 €	HC2-2C	SILENCIEUX	NON	TP-OV3





	REFERENCE	PRIX	GAMME	DESCRIPTION	CE	INTÉRIEUR
	HD 1002 SC	489 €	HC2-3C	SILENCIEUX	NON	TP-OV3
<b>STREET 750 2014-2016</b>						
	HD 1001 SB	462 €	HC2-2B	SILENCIEUX	NON	TP-OV3
	HD 1001 SC	489 €	HC2-2C	SILENCIEUX	NON	TP-OV3
	HD 1002 SC	489 €	HC2-3C	SILENCIEUX	NON	TP-OV3
<b>SPORTSTER XL 883 2004-2013</b>						
	HD 1008 SB	499 €	HC1-3B	SILENCIEUX (SILENCIEUX INFÉRIEUR)	OUI	TP-OV3
	HD 1008 SB	499 €	HC1-3B	SILENCIEUX (SILENCIEUX SUPÉRIEUR)	OUI	TP-OV3
	HD 1008 SC	519 €	HC1-3C	SILENCIEUX (SILENCIEUX SUPÉRIEUR)	OUI	TP-OV3
	HD 1008 SC	519 €	HC1-3C	SILENCIEUX (SILENCIEUX INFÉRIEUR)	OUI	TP-OV3
<b>SPORTSTER XL 883 2014-2016</b>						
	HD 1009 SB	489 €	HC1-3B	SILENCIEUX (SILENCIEUX INFÉRIEUR)	OUI	TP-OV3
	HD 1009 SB	489 €	HC1-3B	SILENCIEUX (SILENCIEUX SUPÉRIEUR)	OUI	TP-OV3
	HD 1009 SC	499 €	HC1-3C	SILENCIEUX (SILENCIEUX INFÉRIEUR)	OUI	TP-OV3
	HD 1009 SC	499 €	HC1-3C	SILENCIEUX (SILENCIEUX SUPÉRIEUR)	OUI	TP-OV3
<b>SPORTSTER XL 1200 2004-2013</b>						
	HD 1008 SB	499 €	HC1-3B	SILENCIEUX (SILENCIEUX INFÉRIEUR)	OUI	TP-OV3
	HD 1008 SB	499 €	HC1-3B	SILENCIEUX (SILENCIEUX SUPÉRIEUR)	OUI	TP-OV3
	HD 1008 SC	519 €	HC1-3C	SILENCIEUX (SILENCIEUX INFÉRIEUR)	OUI	TP-OV3
	HD 1008 SC	519 €	HC1-3C	SILENCIEUX (SILENCIEUX SUPÉRIEUR)	OUI	TP-OV3
<b>SPORTSTER XL 1200 2014-2016</b>						
	HD 1009 SB	489 €	HC1-3B	SILENCIEUX (SILENCIEUX INFÉRIEUR)	OUI	TP-OV3
	HD 1009 SB	489 €	HC1-3B	SILENCIEUX (SILENCIEUX SUPÉRIEUR)	OUI	TP-OV3
	HD 1009 SC	499 €	HC1-3C	SILENCIEUX (SILENCIEUX SUPÉRIEUR)	OUI	TP-OV3
	HD 1009 SC	499 €	HC1-3C	SILENCIEUX (SILENCIEUX INFÉRIEUR)	OUI	TP-OV3
<b>DYNA STREET BOB 2006-2016</b>						
	HD 1006 SB	345 €	HC1-3B	SILENCIEUX (SILENCIEUX SUPÉRIEUR)	NON	TP-OV3
	HD 1006 SB	345 €	HC1-3B	SILENCIEUX (SILENCIEUX INFÉRIEUR)	NON	TP-OV3
	HD 1006 SC	355 €	HC1-3C	SILENCIEUX (SILENCIEUX INFÉRIEUR)	NON	TP-OV3
	HD 1006 SC	355 €	HC1-3C	SILENCIEUX (SILENCIEUX SUPÉRIEUR)	NON	TP-OV3
<b>DYNA LOW RIDER 2014-2016</b>						
	HD 1003 SB	375 €	HC1-2B	SILENCIEUX	NON	TP-OV3





























REFERENCE	PRIX	GAMME	DESCRIPTION	CE	INTÉRIEUR
<b>FAT BOB 18-19</b>					
 HD 1020 SB	465 €	HC2-2B	SILENCIEUX (SILENCIEUX SUPÉRIEUR)	NON	TP-OV3
 HD 1020 SB	465 €	HC2-2C	SILENCIEUX (SILENCIEUX INFÉRIEUR)	NON	TP-OV3
<b>SOFTAIL FAT BOY 2006-2016</b>					
 HD 1007 SB	345 €	HC1-3B	SILENCIEUX (SILENCIEUX INFÉRIEUR)	NON	TP-OV3
 HD 1007 SB	345 €	HC1-3B	SILENCIEUX (SILENCIEUX SUPÉRIEUR)	NON	TP-OV3
 HD 1007 SC	355 €	HC1-3C	SILENCIEUX (SILENCIEUX INFÉRIEUR)	NON	TP-OV3
 HD 1007 SC	355 €	HC1-3C	SILENCIEUX (SILENCIEUX SUPÉRIEUR)	NON	TP-OV3
<b>SOFTAIL FAT BOY 2019</b>					
 HD 1022 SS	345 €	HC1-3S	SILENCIEUX (SILENCIEUX SUPÉRIEUR)	NON	TP-OV3
 HD 1023 SS	345 €	HC1-3S	SILENCIEUX (SILENCIEUX INFÉRIEUR)	NON	TP-OV3
<b>SOFTAIL BREAKOUT 2013-2016</b>					
 HD 1005 SB	345 €	HC1-3B	SILENCIEUX (SILENCIEUX INFÉRIEUR)	NON	TP-OV3
 HD 1005 SB	345 €	HC1-3B	SILENCIEUX (SILENCIEUX SUPÉRIEUR)	NON	TP-OV3
<b>SOFTAIL DELUXE 2007-2016</b>					
 HD 1004 ASC	355 €	HC1-3C	SILENCIEUX (SILENCIEUX SUPÉRIEUR)	NON	TP-OV3
 HD 1004 BSC	355 €	HC1-3C	SILENCIEUX (SILENCIEUX INFÉRIEUR)	NON	TP-OV3
<b>SOFTAIL SLIM 2012-2016</b>					
 HD 1004 ASC	355 €	HC1-3C	SILENCIEUX (SILENCIEUX SUPÉRIEUR)	NON	TP-OV3
 HD 1004 BSC	355 €	HC1-3C	SILENCIEUX (SILENCIEUX INFÉRIEUR)	NON	TP-OV3
<b>TOURING ROAD KING 2006-2016</b>					
 HD 1016 SB	499 €	HC2-1B	SILENCIEUX (COTÉ DROIT)	OUI	TP-OV3
 HD 1016 SC	529 €	HC2-1C	SILENCIEUX (COTÉ DROIT)	OUI	TP-OV3
 HD 1017 SB	499 €	HC2-1B	SILENCIEUX (COTÉ GAUCHE)	OUI	TP-OV3
 HD 1017 SC	529 €	HC2-1C	SILENCIEUX (COTÉ GAUCHE)	OUI	TP-OV3
<b>TOURING ROAD KING 2017</b>					
 HD 1018 SB	499 €	HC2-1B	SILENCIEUX (COTÉ DROIT)	NON	TP-OV3
 HD 1018 SC	529 €	HC2-1C	SILENCIEUX (COTÉ DROIT)	NON	TP-OV3
 HD 1019 SB	499 €	HC2-1B	SILENCIEUX (COTÉ GAUCHE)	NON	TP-OV3
 HD 1019 SC	529 €	HC2-1C	SILENCIEUX (COTÉ GAUCHE)	NON	TP-OV3
<b>HONDA</b>					
<b>SFX 50</b>					
 H 1955	145 €	SCCL	LIGNE COMPLÈTE	OUI	NO

REFERENCE	PRIX	GAMME	DESCRIPTION	CE	INTÉRIEUR
<b>BALI 50</b>					
 H 1955	145 €	SCCL	LIGNE COMPLÈTE	NON	NO
<b>DIO 50</b>					
 K 301	145 €	SCCL	LIGNE COMPLÈTE	NON	NO
<b>VISION 50</b>					
 HP 1951	145 €	SCCL	LIGNE COMPLÈTE	NON	NO
<b>VISION 75</b>					
 H 1950	145 €	SCCL	SILENCIEUX	NON	NO
<b>MSX 125 / GROOM 13-19</b>					
 OH 615 SB	375 €	RCSB	LIGNE COMPLÈTE	NON	TP-OV3
 XH 6315 V	319 €	L2X	LIGNE COMPLÈTE	NON	NO
<b>MONKEY 125 18-19</b>					
 OH 612 SS	375 €	RCS	LIGNE COMPLÈTE	NON	TP-OV3
 XH 6312 V	319 €	L2X	LIGNE COMPLÈTE	NON	NO
<b>CBF 125 09-15 (JC40)</b>					
 OH 6016 VSE	415 €	SOVE	LIGNE COMPLÈTE	NON	TP-OV70
<b>XL 125 V VARADERO 04-15 (JC32)</b>					
 OH 6011 VSE	415 €	SOVE	SILENCIEUX	OUI	TP-OV70
<b>CBR 125 R 04-10 (JC34,JC39)</b>					
 OH 6013 VSE	345 €	SOVE	SILENCIEUX	NON	TP-OV70
<b>CBR 125 R 11-15</b>					
 OH 6018 VSE	415 €	SOVE	SILENCIEUX	NON	TP-OV70
 XH 6318 V	299 €	L2X	SILENCIEUX	NON	NO
<b>CB 125 R '18 (JC79)</b>					
 OH 608 RRB	745 €	RC1B	LIGNE COMPLÈTE	OUI	TP-OVC12
<b>CBR 250 R 11-14</b>					
 OH 6019 VSE	489 €	SOVE	LIGNE COMPLÈTE	NON	TP-OV70
 OH 6219 VSE	415 €	SOVE	SILENCIEUX	NON	TP-OV70
 XH 6319 XB	449 €	L3XB	SILENCIEUX	NON	TP-HP4
<b>VTR 250 '98 CARBURATOR</b>					
 OH 6017 VSE	519 €	SOVE	LIGNE COMPLÈTE	NON	TP-OV70
<b>VTR 250i 10-14</b>					
 OH 6020 VSE	519 €	SOVE	LIGNE COMPLÈTE	NON	TP-OV70
 OH 6020 VSEB	619 €	XOVE	LIGNE COMPLÈTE	NON	TP-OV70
<b>CBR 300 R 15-17</b>					
 OH 6127 VSE	489 €	SOVE	LIGNE COMPLÈTE	NON	TP-OV70





























	REFERENCE	PRIX	GAMME	DESCRIPTION	CE	INTÉRIEUR
	OH 6219 VSE	415 €	SOVE	SILENCIEUX	NON	TP-OV70
	XH 6327 XB	449 €	L3XB	SILENCIEUX	NON	TP-HP4
<b>CB 300 R 18-19</b>						
	OH 630 RR	435 €	RC1	SILENCIEUX	NON	TP-OVC12
	OH 630 RRB	465 €	RC1B	SILENCIEUX	NON	TP-OVC12
	XH 6230 XN	449 €	L3N	SILENCIEUX	NON	TP-HP2
<b>CB 400 EFI 08-12</b>						
	OH 6026 VSE	415 €	SOVE	SILENCIEUX	NON	TP-OV70
<b>TRX 400 EX SPORTRAX 99-04</b>						
	AH 6425 EV	369 €	SOVE	SILENCIEUX	NON	TP-OV70
<b>REBEL CMX 500</b>						
	XH 6335 XB	449 €	L3XB	SILENCIEUX	NON	TP-HP4
<b>CB 500 / S 93-04 (PC32)</b>						
	OH 6031 VSE	415 €	SOVE	SILENCIEUX	OUI	TP-OV70
	OH 6031 VSEB	439 €	XOVE	SILENCIEUX	OUI	TP-OV70
<b>CBF 500 04-11 (PC39)</b>						
	OH 6032 VSE	415 €	SOVE	SILENCIEUX	OUI	TP-OV70
	OH 6032 VSEB	439 €	XOVE	SILENCIEUX	OUI	TP-OV70
<b>CBR 500 R 13-15 (PC44)</b>						
	FH 6833 SSB	419 €	X55SB	SILENCIEUX	OUI	TP-X55SS
	KIT 6133 C1	225 €	DKAT	DKAT - COLECTEUR	NON	NO
	OH 6033 VSE	415 €	SOVE	SILENCIEUX	OUI	TP-OV70
	OH 6033 VSEB	529 €	XOVE	SILENCIEUX	OUI	TP-OV70
	OH 6033 VTI	645 €	VTI	SILENCIEUX	OUI	TP-OV3
	XH 6333 XB	449 €	L3XB	SILENCIEUX	OUI	TP-HP4
<b>CB 500 F 13-15 (PC45)</b>						
	FH 6833 SSB	419 €	X55SB	SILENCIEUX	OUI	TP-X55SS
	KIT 6133 C1	225 €	DKAT	DKAT - COLECTEUR	NON	NO
	OH 6033 VSE	415 €	SOVE	SILENCIEUX	OUI	TP-OV70
	OH 6033 VSEB	529 €	XOVE	SILENCIEUX	OUI	TP-OV70
	OH 6033 VTI	645 €	VTI	SILENCIEUX	OUI	TP-OV3
	XH 6333 XB	449 €	L3XB	SILENCIEUX	OUI	TP-HP4

	REFERENCE	PRIX	GAMME	DESCRIPTION	CE	INTÉRIEUR
<b>CB 500 X 13-16 (PC46)</b>						
	FH 6833 SSB	419 €	X55SB	SILENCIEUX	OUI	TP-X55SS
	OH 6033 VSE	415 €	SOVE	SILENCIEUX	OUI	TP-OV70
	OH 6033 VSEB	529 €	XOVE	SILENCIEUX	OUI	TP-OV70
	OH 6033 VTI	645 €	VTI	SILENCIEUX	OUI	TP-OV3
	XH 6333 XB	449 €	L3XB	SILENCIEUX	OUI	TP-HP4
<b>CBR 500 R 16-18 (PC57)</b>						
	FH 6834 SSB	419 €	X55SB	SILENCIEUX	OUI	TP-X55SS
	OH 6033 VSE	415 €	SOVE	SILENCIEUX	OUI	TP-OV70
	OH 6033 VSEB	529 €	XOVE	SILENCIEUX	OUI	TP-OV70
	OH 6033 VTI	645 €	VTI	SILENCIEUX	OUI	TP-OV3
	OH 634 RRB	465 €	RC1B	SILENCIEUX	OUI	TP-OVC12
	XH 6334 XB	449 €	L3XB	SILENCIEUX	OUI	TP-HP4
<b>CB 500 F 16-18 (PC58)</b>						
	FH 6834 SSB	419 €	X55SB	SILENCIEUX	OUI	TP-X55SS
	OH 6033 VSE	415 €	SOVE	SILENCIEUX	OUI	TP-OV70
	OH 6033 VSEB	529 €	XOVE	SILENCIEUX	OUI	TP-OV70
	OH 6033 VTI	645 €	VTI	SILENCIEUX	OUI	TP-OV3
	OH 634 RRB	465 €	RC1B	SILENCIEUX	OUI	TP-OVC12
	XH 6334 XB	449 €	L3XB	SILENCIEUX	OUI	TP-HP4
<b>CB 500 X 17-18 (PC59)</b>						
	FH 6834 SSB	419 €	X55SB	SILENCIEUX	OUI	TP-X55SS
	OH 6033 VSE	415 €	SOVE	SILENCIEUX	OUI	TP-OV70
	OH 6033 VSEB	529 €	XOVE	SILENCIEUX	OUI	TP-OV70
	OH 6033 VTI	645 €	VTI	SILENCIEUX	OUI	TP-OV3
	OH 634 RRB	465 €	RC1B	SILENCIEUX	OUI	TP-OVC12
	XH 6334 XB	449 €	L3XB	SILENCIEUX	OUI	TP-HP4
<b>CBR 500 R 19-20 (PC62)</b>						
	OH 636 RRB	465 €	RC1B	SILENCIEUX	OUI	TP-OVC12
	XH 6336 XB	449 €	L3XB	SILENCIEUX	OUI	TP-HP4
<b>CB 500 F 19-20 (PC63)</b>						
	OH 636 RRB	465 €	RC1B	SILENCIEUX	OUI	TP-OVC12



























REFERENCE	PRIX	GAMME	DESCRIPTION	CE	INTÉRIEUR
 XH 6336 XB	449 €	L3XB	SILENCIEUX	OUI	TP-HP4
<b>CB 500 X 19-20 (PC64)</b>					
 OH 636 RRB	465 €	RC1B	SILENCIEUX	OUI	TP-OVC12
 XH 6336 XB	449 €	L3XB	SILENCIEUX	OUI	TP-HP4
<b>CB 600 F/S HORNET 07-14 (PC41)</b>					
 FH 6848 SS	375 €	X55S	SILENCIEUX	OUI	TP-X55SS
 OH 6048 VSE	429 €	SOVE	SILENCIEUX	OUI	TP-OV70
 XH 6348 V	299 €	L2X	SILENCIEUX	OUI	NO
<b>CBF 600 04-11 (PC38)</b>					
 OH 6057 VSE	415 €	SOVE	SILENCIEUX	OUI	TP-OV70
 OH 6057 VSEB	439 €	XOVE	SILENCIEUX	OUI	TP-OV70
<b>CBR 600 F 87-90 (PC19,PC23)</b>					
 OH 6043 VSE	415 €	SOVE	SILENCIEUX	NON	TP-OV70
<b>CBR 600 F 91-98 (PC25,PC31)</b>					
 OH 6041 VSE	415 €	SOVE	SILENCIEUX	OUI	TP-OV70
 OH 6041 VSEB	439 €	XOVE	SILENCIEUX	OUI	TP-OV70
<b>CBR 600 F 99-00 (PC35)</b>					
 OH 6049 VSE	415 €	SOVE	SILENCIEUX	OUI	TP-OV70
 OH 6049 VSEB	439 €	XOVE	SILENCIEUX	OUI	TP-OV70
<b>CBR 600 F 01-07 (PC35F)</b>					
 OH 6052 VSE	429 €	SOVE	SILENCIEUX	NON	TP-OV70
 OH 6052 VSEB	513 €	XOVE	SILENCIEUX	NON	TP-OV70
<b>CBR 600 F SPORT 01-02 (PC35H)</b>					
 OH 6052 VSE	429 €	SOVE	SILENCIEUX	NON	TP-OV70
 OH 6052 VSEB	529 €	XOVE	SILENCIEUX	NON	TP-OV70
<b>CBR 600 F 11-14 (PC41)</b>					
 FH 6848 SS	375 €	X55S	SILENCIEUX	OUI	TP-X55SS
 OH 6048 VSE	429 €	SOVE	SILENCIEUX	OUI	TP-OV70
 XH 6348 V	299 €	L2X	SILENCIEUX	OUI	NO
<b>CB 650 F 14-18 (RC75,RC97)</b>					
 FH 6856 SSB	729 €	X55SB	LIGNE COMPLÈTE	OUI	TP-X55SS
 SH 6756 C	999 €	SX1	LIGNE COMPLÈTE	OUI	TP-OV6
 XH 6356 XB	889 €	L3XB	LIGNE COMPLÈTE	OUI	TP-HP4









REFERENCE	PRIX	GAMME	DESCRIPTION	CE	INTÉRIEUR
<b>CB 650 R 19-20 (RH02)</b>					
 CH 6156 RC	949 €	RC	LIGNE COMPLÈTE	OUI	NO
 FH 6856 SSB	729 €	X55SB	LIGNE COMPLÈTE	OUI	TP-X55SS
 SH 6756 C	999 €	SX1	LIGNE COMPLÈTE	OUI	TP-OV6
 XH 6356 XB	889 €	L3XB	LIGNE COMPLÈTE	OUI	TP-HP4
<b>CBR 650 F 15-18 (RC74,RC96)</b>					
 FH 6856 SSB	729 €	X55SB	LIGNE COMPLÈTE	OUI	TP-X55SS
 SH 6756 C	999 €	SX1	LIGNE COMPLÈTE	OUI	TP-OV6
 XH 6356 XB	889 €	L3XB	LIGNE COMPLÈTE	OUI	TP-HP4
<b>CBR 650 R 19-20 (RH01)</b>					
 CH 6156 RC	949 €	RC	LIGNE COMPLÈTE	OUI	NO
 FH 6856 SSB	729 €	X55SB	LIGNE COMPLÈTE	OUI	TP-X55SS
 SH 6756 C	999 €	SX1	LIGNE COMPLÈTE	OUI	TP-OV6
 XH 6356 XB	889 €	L3XB	LIGNE COMPLÈTE	OUI	TP-HP4
<b>NC 700 X / S / INTEGRA 12-13 (RC61,RC62,RC63)</b>					
 FH 6862 SSB	411 €	X55SB	SILENCIEUX	OUI	TP-X55SS
 OH 6062 VSE	415 €	SOVE	SILENCIEUX	OUI	TP-OV70
 OH 6062 VSEB	439 €	XOVE	SILENCIEUX	OUI	TP-OV70
 OH 6062 VTI	619 €	VTI	SILENCIEUX	OUI	TP-OV3
 XH 6362 XB	449 €	L3XB	SILENCIEUX	OUI	TP-HP4
<b>NC 750 X / S / INTEGRA 14-15 (RC70)</b>					
 FH 6862 SSB	419 €	X55SB	SILENCIEUX	OUI	TP-X55SS
 OH 6062 VSE	415 €	SOVE	SILENCIEUX	OUI	TP-OV70
 OH 6062 VSEB	439 €	XOVE	SILENCIEUX	OUI	TP-OV70
 OH 6062 VTI	619 €	VTI	SILENCIEUX	OUI	TP-OV3
 XH 6362 XB	449 €	L3XB	SILENCIEUX	OUI	TP-HP4
<b>NC 750 X / S / INTEGRA 16-19 (RC88,RC89,RC90,RC92)</b>					
 FH 6862 SSB	419 €	X55SB	SILENCIEUX	OUI	TP-X55SS
 OH 6062 VSE	415 €	SOVE	SILENCIEUX	OUI	TP-OV70
 OH 6062 VSEB	439 €	XOVE	SILENCIEUX	OUI	TP-OV70
 OH 6062 VTI	619 €	VTI	SILENCIEUX	OUI	TP-OV3
 XH 6362 XB	449 €	L3XB	SILENCIEUX	OUI	TP-HP4











REFERENCE	PRIX	GAMME	DESCRIPTION	CE	INTÉRIEUR
<b>X-ADV 750 17-19 (RC95)</b>					
 OH 6059 VSE	415 €	SOVE	SILENCIEUX	OUI	TP-OV70
 OH 6059 VTI	619 €	VTI	SILENCIEUX	OUI	TP-OV3
 OH 659 RR	435 €	RC1	SILENCIEUX	OUI	TP-OVC12
 OH 659 RRB	465 €	RC1B	SILENCIEUX	OUI	TP-OVC12
<b>VFR 750 F 90-93 (RC36)</b>					
 OH 6060 VSE	415 €	SOVE	SILENCIEUX	OUI	TP-OV70
 OH 6060 VSEB	439 €	XOVE	SILENCIEUX	OUI	TP-OV70
<b>VFR 750 F 94-97 (RC36-2)</b>					
 OH 6061 VSE	415 €	SOVE	SILENCIEUX	OUI	TP-OV70
 OH 6061 VSEB	439 €	XOVE	SILENCIEUX	OUI	TP-OV70
<b>RVF 750 R '94 (RC45)</b>					
 OH 6065 VSE	345 €	SOVE	SILENCIEUX	NON	TP-OV70
<b>VFR 800 Fi 98-01 (RC46)</b>					
 OH 6063 VSE	415 €	SOVE	SILENCIEUX	OUI	TP-OV70
<b>VFR 800 X CROSSRUNNER 11-14 (RC60)</b>					
 OH 6068 VSE	415 €	SOVE	SILENCIEUX	OUI	TP-OV70
 XH 6368 XB	449 €	L3XB	SILENCIEUX	OUI	TP-HP4
<b>VFR 800 F 14-18</b>					
 OH 6058 VSE	415 €	SOVE	SILENCIEUX	NON	TP-OV70
<b>VFR 800 X CROSSRUNNER 15-18 (RC80)</b>					
 OH 6058 VSE	415 €	SOVE	SILENCIEUX	NON	TP-OV70
<b>CB 900 F HORNET 03-07 (SC48)</b>					
 OH 6198 VSE	422 €	SOVE	SILENCIEUX	OUI	TP-OV70
<b>CBR 900 RR 92-95 (SC28)</b>					
 OH 6081 VSE	345 €	SOVE	SILENCIEUX	OUI	TP-OV70
<b>CBR 900 RR 96-97 (SC29)</b>					
 OH 6087 VSE	345 €	SOVE	SILENCIEUX	NON	TP-OV70
<b>CBR 900 RR 98-99 (SC33)</b>					
 OH 6093 VSE	345 €	SOVE	SILENCIEUX	OUI	TP-OV70
<b>CBR 900 RR 00-03 (SC44,SC50)</b>					
 OH 6095 VSE	345 €	SOVE	SILENCIEUX	NON	TP-OV70
 OH 6095 VSEB	375 €	XOVE	SILENCIEUX	NON	TP-OV70
<b>CB 1000 BIG ONE MADE IN JAPAN (SC30A)</b>					
 OH 6083 JVSE	345 €	SOVE	SILENCIEUX	OUI	TP-OV70

REFERENCE	PRIX	GAMME	DESCRIPTION	CE	INTÉRIEUR
<b>CB 1000 BIG ONE MADE IN USA (SC30)</b>					
 OH 6083 VSE	345 €	SOVE	SILENCIEUX	OUI	TP-OV70
<b>CBF 1000 10-15</b>					
 OH 6080 VSE	415 €	SOVE	SILENCIEUX	NON	TP-OV70
<b>VTR 1000 F 97-05 (SC36)</b>					
 OH 6088 VSE	415 €	SOVE	SILENCIEUX (COTÉ DROIT)	OUI	TP-OV70
 OH 6089 VSE	415 €	SOVE	SILENCIEUX (COTÉ GAUCHE)	OUI	TP-OV70
<b>VTR 1000 SP1 (SC45)</b>					
 OH 6096 VSE	415 €	SOVE	SILENCIEUX (COTÉ DROIT)	OUI	TP-OV70
 OH 6097 VSE	415 €	SOVE	SILENCIEUX (COTÉ GAUCHE)	OUI	TP-OV70
<b>VTR 1000 SP2</b>					
 OH 6072 VSE	415 €	SOVE	SILENCIEUX (COTÉ DROIT)	NON	TP-OV70
 OH 6073 VSE	415 €	SOVE	SILENCIEUX (COTÉ GAUCHE)	NON	TP-OV70
<b>CB 1000 R HORNET 08-17 (SC60)</b>					
 FH 6877 SS	375 €	X55S	SILENCIEUX	OUI	TP-X55SS
 KIT 6077 C1	155 €	DKAT	DKAT - TUBE RACCORD	NON	NO
 OH 6077 VSE	429 €	SOVE	SILENCIEUX	OUI	TP-OV70
 SH 6777 C	999 €	SX1	SILENCIEUX	NON	TP-OV6
 XH 6377 V	345 €	L2X	SILENCIEUX	OUI	NO
<b>CB 1000 R 18-19 (SC80)</b>					
 CH 6278 RC	329 €	RC	SILENCIEUX	OUI	NO
 KIT 6178 C1	579 €	DKAT	DKAT - COLECTEUR	NON	NO
 OH 678 RR	435 €	RC1	SILENCIEUX	OUI	TP-OVC12
 OH 678 RRB	465 €	RC1B	SILENCIEUX	OUI	TP-OVC12
 XH 6278 XN	449 €	L3N	SILENCIEUX	OUI	TP-HP4
<b>CRF 1000 L AFRICA TWIN 16-19 (SD04,SD06)</b>					
 EH 6082 SS	565 €	MXT	SILENCIEUX	OUI	TP-MXT80
 OH 6074 VSE	415 €	SOVE	SILENCIEUX	OUI	TP-OV70
 OH 6074 VSEB	439 €	XOVE	SILENCIEUX	OUI	TP-OV70
<b>CBR 1000 RR 08-14 (SC59)</b>					
 OH 6175 VSE	565 €	SOVE	SILENCIEUX	NON	TP-OV70
<b>CBR 1000 RR 17-19</b>					
 CH 6276 RC	329 €	RC	SILENCIEUX	NON	NO
 OH 676 RRB	465 €	RC1B	SILENCIEUX	NON	TP-OVC12

































REFERENCE	PRIX	GAMME	DESCRIPTION	CE	INTÉRIEUR
<b>CB 1100 13-15</b>					
 OH 6086 VSE	415 €	SOVE	SILENCIEUX	NON	TP-OV70
<b>CB 1100 EX / RS 16-19</b>					
 HH 6100 SS	355 €	HC1-3S	SILENCIEUX (COTÉ DROIT)	NON	TP-OV70
 HH 6101 SS	355 €	HC1-3S	SILENCIEUX (COTÉ GAUCHE)	NON	TP-OV70
<b>CBR 1100 XX (SC35)</b>					
 OH 6090 VSE	415 €	SOVE	SILENCIEUX (COTÉ DROIT)	OUI	TP-OV70
 OH 6091 VSE	415 €	SOVE	SILENCIEUX (COTÉ GAUCHE)	OUI	TP-OV70
<b>VFR 1200 F 10-17</b>					
 OH 6064 VSE	429 €	SOVE	SILENCIEUX	NON	TP-OV70
<b>VFR 1200 X CROSSTOURER 12-17</b>					
 OH 6071 VSE	429 €	SOVE	SILENCIEUX	NON	TP-OV70
<b>CB 1300 S / CB 1300 SF 03-14 (SC54)</b>					
 OH 6094 VSE	415 €	SOVE	SILENCIEUX	NON	TP-OV70
 OH 6094 VTI	619 €	VTI	SILENCIEUX	NON	TP-OV3

## HYOSUNG

<b>GT 125 COMET</b>					
 OG 4021 VSE	345 €	SOVE	SILENCIEUX	OUI	TP-OV70
<b>GT 250 COMET</b>					
 OG 4021 VSE	345 €	SOVE	SILENCIEUX	OUI	TP-OV70
<b>GD 250 EXIV</b>					
 OG 4031 VSE	415 €	SOVE	SILENCIEUX	NON	TP-OV70
 XG 4331 XB	449 €	L3XB	SILENCIEUX	NON	TP-HP4
<b>GV 650 AQUILA 06-13</b>					
 OG 4053 VSE	345 €	SOVE	SILENCIEUX	NON	TP-OV70
 OG 4053 VSEB	375 €	XOVE	SILENCIEUX	NON	TP-OV70
<b>GT 650 S / R / Ri (GT650)</b>					
 OG 4051 VSE	345 €	SOVE	SILENCIEUX	OUI	TP-OV70
 OG 4051 VSEB	375 €	XOVE	SILENCIEUX	OUI	TP-OV70

## INDIAN

<b>SCOUT 15-19</b>					
 HI 2001 SB	375 €	HC1-2B	SILENCIEUX (SILENCIEUX SUPÉRIEUR)	NON	TP-OV3
 HI 2001 SC	389 €	HC1-2C	SILENCIEUX (SILENCIEUX SUPÉRIEUR)	NON	TP-OV3
 HI 2002 SB	375 €	HC1-2B	SILENCIEUX (SILENCIEUX INFÉRIEUR)	NON	TP-OV3
 HI 2002 SC	389 €	HC1-2C	SILENCIEUX (SILENCIEUX INFÉRIEUR)	NON	TP-OV3

REFERENCE	PRIX	GAMME	DESCRIPTION	CE	INTÉRIEUR
<b>SCOUT BOBBER 15-19</b>					
 HI 2001 SB	375 €	HC1-2B	SILENCIEUX (SILENCIEUX SUPÉRIEUR)	NON	TP-OV3
 HI 2001 SC	389 €	HC1-2C	SILENCIEUX (SILENCIEUX SUPÉRIEUR)	NON	TP-OV3
 HI 2002 SB	375 €	HC1-2B	SILENCIEUX (SILENCIEUX INFÉRIEUR)	NON	TP-OV3
 HI 2002 SC	389 €	HC1-2C	SILENCIEUX (SILENCIEUX INFÉRIEUR)	NON	TP-OV3
<b>CHIEF 15-19</b>					
 HI 2018 SB	499 €	HC2-1B	SILENCIEUX (COTÉ DROIT)	NON	TP-OV3
 HI 2018 SC	529 €	HC2-1C	SILENCIEUX (COTÉ DROIT)	NON	TP-OV3
 HI 2019 SB	499 €	HC2-1B	SILENCIEUX (COTÉ GAUCHE)	NON	TP-OV3
 HI 2019 SC	529 €	HC2-1C	SILENCIEUX (COTÉ GAUCHE)	NON	TP-OV3
<b>CHIEF DARK HORSE 15-19</b>					
 HI 2018 SB	499 €	HC2-1B	SILENCIEUX (COTÉ DROIT)	NON	TP-OV3
 HI 2018 SC	529 €	HC2-1C	SILENCIEUX (COTÉ DROIT)	NON	TP-OV3
 HI 2019 SB	499 €	HC2-1B	SILENCIEUX (COTÉ GAUCHE)	NON	TP-OV3
 HI 2019 SC	529 €	HC2-1C	SILENCIEUX (COTÉ GAUCHE)	NON	TP-OV3
<b>CHIEFTAIN 15-19</b>					
 HI 2016 SB	499 €	HC2-1B	SILENCIEUX (COTÉ DROIT)	NON	TP-OV3
 HI 2016 SC	529 €	HC2-1C	SILENCIEUX (COTÉ DROIT)	NON	TP-OV3
 HI 2017 SB	499 €	HC2-1B	SILENCIEUX (COTÉ GAUCHE)	NON	TP-OV3
 HI 2017 SC	529 €	HC2-1C	SILENCIEUX (COTÉ GAUCHE)	NON	TP-OV3
<b>ROADMASTER 15-19</b>					
 HI 2016 SB	499 €	HC2-1B	SILENCIEUX (COTÉ DROIT)	NON	TP-OV3
 HI 2016 SC	529 €	HC2-1C	SILENCIEUX (COTÉ DROIT)	NON	TP-OV3
 HI 2017 SB	499 €	HC2-1B	SILENCIEUX (COTÉ GAUCHE)	NON	TP-OV3
 HI 2017 SC	529 €	HC2-1C	SILENCIEUX (COTÉ GAUCHE)	NON	TP-OV3
<b>SPRINGFIELD 15-19</b>					
 HI 2016 SB	499 €	HC2-1B	SILENCIEUX (COTÉ DROIT)	NON	TP-OV3
 HI 2016 SC	529 €	HC2-1C	SILENCIEUX (COTÉ DROIT)	NON	TP-OV3
 HI 2017 SB	499 €	HC2-1B	SILENCIEUX (COTÉ GAUCHE)	NON	TP-OV3
 HI 2017 SC	529 €	HC2-1C	SILENCIEUX (COTÉ GAUCHE)	NON	TP-OV3
<b>FTR 1200 / FTR 1200 S 18-20</b>					
 CI 2220 RC	658 €	RC	SILENCIEUX DUAL (INFÉRIEUR ET SUPÉRIEUR)	NON	NO
 KIT 2220 C1	155 €	DKAT	DKAT - TUBE RACCORD	NON	NO



REFERENCE	PRIX	GAMME	DESCRIPTION	CE	INTÉRIEUR
-----------	------	-------	-------------	----	-----------

### ITALJET

#### ITALJET DRAGSTER 50 - MINARELLI HORIZONTAL

	YAM 2326	125 €	SCCL	LIGNE COMPLÈTE	NON	NO
---	----------	-------	------	----------------	-----	----

#### ITALJET FORMULA L.C. - MINARELLI HORIZONTAL

	YAM 2326	125 €	SCCL	LIGNE COMPLÈTE	NON	NO
---	----------	-------	------	----------------	-----	----

#### ITALJET PISTA 50 - MINARELLI VERTICAL

	YAM 2334	125 €	SCCL	LIGNE COMPLÈTE	NON	NO
---	----------	-------	------	----------------	-----	----

#### ITALJET SCOOP / REPORTER 50 - MINARELLI VERTICAL

	YAM 2334	125 €	SCCL	LIGNE COMPLÈTE	NON	NO
---	----------	-------	------	----------------	-----	----

### KAWASAKI

#### Z 125 / NINJA 125 2019

	OK 7037 VSEB	439 €	XOVE	SILENCIEUX	NON	TP-OV70
---	--------------	-------	------	------------	-----	---------

	XK 7337 XB	449 €	L3XB	SILENCIEUX	NON	TP-HP4
---	------------	-------	------	------------	-----	--------

#### NINJA 250 R 08-12 (EX250K)

	FK 7834 SSB	411 €	X55SB	SILENCIEUX	OUI	TP-X55SS
---	-------------	-------	-------	------------	-----	----------

	OK 7034 VSE	415 €	SOVE	SILENCIEUX	OUI	TP-OV70
---	-------------	-------	------	------------	-----	---------

	XK 7334 XB	449 €	L3XB	SILENCIEUX	OUI	TP-HP4
---	------------	-------	------	------------	-----	--------

#### NINJA 250-300 R 13-15 (ER300A)

	FK 7836 SS	375 €	X55S	SILENCIEUX	OUI	TP-X55SS
--	------------	-------	------	------------	-----	----------

	OK 7036 VSE	415 €	SOVE	SILENCIEUX	OUI	TP-OV70
---	-------------	-------	------	------------	-----	---------

	XK 7336 XB	449 €	L3XB	SILENCIEUX	OUI	TP-HP4
---	------------	-------	------	------------	-----	--------

#### NINJA 250-300 R 13-15

	OK 7136 VSE	565 €	SOVE	LIGNE COMPLÈTE	NON	TP-OV70
---	-------------	-------	------	----------------	-----	---------

#### NINJA 250 SL / Z 250 SL 15-17

	OK 7037 VSEB	439 €	XOVE	SILENCIEUX	NON	TP-OV70
---	--------------	-------	------	------------	-----	---------

	XK 7337 XB	449 €	L3XB	SILENCIEUX	NON	TP-HP4
---	------------	-------	------	------------	-----	--------

#### Z 300 (EX300A)

	FK 7836 SS	375 €	X55S	SILENCIEUX	OUI	TP-X55SS
---	------------	-------	------	------------	-----	----------

	OK 7036 VSE	415 €	SOVE	SILENCIEUX	OUI	TP-OV70
---	-------------	-------	------	------------	-----	---------

	OK 7136 VSE	565 €	SOVE	LIGNE COMPLÈTE	NON	TP-OV70
---	-------------	-------	------	----------------	-----	---------

	XK 7336 XB	449 €	L3XB	SILENCIEUX	OUI	TP-HP4
---	------------	-------	------	------------	-----	--------

#### VERSYS-X 300 17-19 (LE300C)

	OK 7039 VSE	415 €	SOVE	SILENCIEUX	NON	TP-OV70
---	-------------	-------	------	------------	-----	---------

#### NINJA 400 18-19 (EX400G)

	CK 7240 RC	329 €	RC	SILENCIEUX	NON	NO
---	------------	-------	----	------------	-----	----

REFERENCE	PRIX	GAMME	DESCRIPTION	CE	INTÉRIEUR
-----------	------	-------	-------------	----	-----------

	OK 7040 VSE	415 €	SOVE	SILENCIEUX	OUI	TP-OV70
---	-------------	-------	------	------------	-----	---------

	OK 7140 RR	629 €	RC1	LIGNE COMPLÈTE (SSP300)	NON	NO
---	------------	-------	-----	-------------------------	-----	----

	OK 740 RRB	465 €	RC1B	SILENCIEUX	SI	TP-OVC12
---	------------	-------	------	------------	----	----------

	OK 7540 VTR	859 €	VTI	LIGNE COMPLÈTE (SSP300)	NON	NO
---	-------------	-------	-----	-------------------------	-----	----

	XK 7240 XN	449 €	L3N	SILENCIEUX	NON	TP-HP2
---	------------	-------	-----	------------	-----	--------

#### Z 400 2019 (EX400G)

	CK 7240 RC	329 €	RC	SILENCIEUX	NON	NO
---	------------	-------	----	------------	-----	----

	OK 7040 VSE	415 €	SOVE	SILENCIEUX	OUI	TP-OV70
---	-------------	-------	------	------------	-----	---------

	OK 7140 RR	629 €	RC1	LIGNE COMPLÈTE (SSP300)	NON	TP-OVC12
---	------------	-------	-----	-------------------------	-----	----------

	OK 740 RRB	465 €	RC1B	SILENCIEUX	NON	TP-OVC12
---	------------	-------	------	------------	-----	----------

	OK 7540 VTR	859 €	VTI	LIGNE COMPLÈTE (SSP300)	NON	NO
---	-------------	-------	-----	-------------------------	-----	----

	XK 7240 XN	449 €	L3N	SILENCIEUX	NON	TP-HP2
---	------------	-------	-----	------------	-----	--------

#### GPZ 500 / S (EX500)

	OK 7032 VSE	415 €	SOVE	SILENCIEUX (COTÉ DROIT)	NON	TP-OV70
---	-------------	-------	------	-------------------------	-----	---------

	OK 7033 VSE	415 €	SOVE	SILENCIEUX (COTÉ GAUCHE)	NON	TP-OV70
---	-------------	-------	------	--------------------------	-----	---------

#### ER-5 (ER500A)

	OK 7031 VSE	415 €	SOVE	SILENCIEUX	OUI	TP-OV70
---	-------------	-------	------	------------	-----	---------

#### ZEPHYR 550 (ZR550B)

	OK 7021 VSE	415 €	SOVE	SILENCIEUX	NON	TP-OV70
---	-------------	-------	------	------------	-----	---------

#### ER-6 05-11 (EX650A,C,D / ER650A,C,D)

	OK 7050 VSE	415 €	SOVE	SILENCIEUX	OUI	TP-OV70
---	-------------	-------	------	------------	-----	---------

	OK 7050 VSEB	439 €	XOVE	SILENCIEUX	OUI	TP-OV70
---	--------------	-------	------	------------	-----	---------

	XK 7351 XB	529 €	L3XB	SILENCIEUX	OUI	TP-HP4
---	------------	-------	------	------------	-----	--------

#### ER-6 12-16 (EX650E,F / ER650E,F)

	FK 7852 SSB	598 €	X55SB	LIGNE COMPLÈTE	OUI	TP-X55SS
---	-------------	-------	-------	----------------	-----	----------

	OK 7052 VSE	659 €	SOVE	LIGNE COMPLÈTE	OUI	TP-OV70
---	-------------	-------	------	----------------	-----	---------

	SK 7752 C	849 €	SX1	LIGNE COMPLÈTE	OUI	TP-OV6
---	-----------	-------	-----	----------------	-----	--------

	XK 7352 XB	669 €	L3XB	LIGNE COMPLÈTE	NON	TP-HP4
---	------------	-------	------	----------------	-----	--------

#### Z650 / NINJA 650 17-19 (ER650H,EX650K)

	CK 7154 RB	669 €	RC	LIGNE COMPLÈTE	OUI	NO
---	------------	-------	----	----------------	-----	----

	CK 7154 RC	729 €	RC	LIGNE COMPLÈTE	OUI	NO
---	------------	-------	----	----------------	-----	----

	FK 7853 SSB	619 €	X55SB	LIGNE COMPLÈTE	OUI	TP-X55SS
---	-------------	-------	-------	----------------	-----	----------



























	OK 7053 VSE	659 €	SOVE	LIGNE COMPLÈTE	OUI	TP-OV70
---	-------------	-------	------	----------------	-----	---------





























	REFERENCE	PRIX	GAMME	DESCRIPTION	CE	INTÉRIEUR
	OK 753 RRB	895 €	RC1B	LIGNE COMPLÈTE	OUI	TP-OVC12
	SK 7753 C	865 €	SX1	LIGNE COMPLÈTE	OUI	TP-OV6
	XK 7353 XB	669 €	L3XB	LIGNE COMPLÈTE	OUI	TP-HP4
<b>Z650 / NINJA 650 2020 (ER650K)</b>						
	CK 7154 RB	669 €	RC	LIGNE COMPLÈTE	OUI	NO
	CK 7154 RC	729 €	RC	LIGNE COMPLÈTE	OUI	NO
<b>VN 650 VULCAN S 15-19</b>						
	SK 7755 C	919 €	SX1	LIGNE COMPLÈTE	NON	TP-OV6
<b>ZX-6 R NINJA 94-97 (ZX600F)</b>						
	OK 7041 VSE	345 €	SOVE	SILENCIEUX	OUI	TP-OV70
<b>ZX-6 R NINJA 98-02 (ZX600G)</b>						
	OK 7045 VSE	345 €	SOVE	SILENCIEUX	OUI	TP-OV70
<b>ZX 636 R 02 (ZX636A)</b>						
	OK 7045 VSE	345 €	SOVE	SILENCIEUX	NON	TP-OV70
<b>ZX 636 R / RR 03-04 (ZX636B)</b>						
	OK 7047 VSE	415 €	SOVE	SILENCIEUX	OUI	TP-OV70
<b>ZX-6 R 09-13 (ZX600R)</b>						
	KIT 7144 C1	89 €	DKAT	DKAT - TUBE RACCORD	NON	NO
	OK 7144 VSE	415 €	SOVE	SILENCIEUX	NON	TP-OV70
	XK 7344 V	299 €	L2X	SILENCIEUX	NON	NO
<b>ZX 636 R 13-19</b>						
	KIT 7144 C1	89 €	DKAT	DKAT - TUBE RACCORD	NON	NO
	OK 7144 VSE	415 €	SOVE	SILENCIEUX	NON	TP-OV70
	OK 7544 VTR	619 €	VTI	SILENCIEUX (SBK EDITION)	NON	NO
	XK 7344 V	299 €	L2X	SILENCIEUX	NON	NO
<b>VERSYS 650 06-14 (LE650A,C,D,E)</b>						
	OK 7050 VSE	415 €	SOVE	SILENCIEUX	OUI	TP-OV70
	OK 7050 VSEB	439 €	XOVE	SILENCIEUX	OUI	TP-OV70
	XK 7351 XB	529 €	L3XB	SILENCIEUX	OUI	TP-HP4
<b>VERSYS 650 15-19 (LE650E,F)</b>						
	FK 7852 SSB	619 €	X55SB	LIGNE COMPLÈTE	OUI	TP-X55SS
	OK 7052 VSE	659 €	SOVE	LIGNE COMPLÈTE	OUI	TP-OV70
	SK 7752 C	865 €	SX1	LIGNE COMPLÈTE	OUI	TP-OV6
	XK 7352 XB	669 €	L3XB	LIGNE COMPLÈTE	NON	TP-HP4

	REFERENCE	PRIX	GAMME	DESCRIPTION	CE	INTÉRIEUR
<b>ZR-7 F / S (ZR750F,ZR750H)</b>						
	OK 7067 VSE	345 €	SOVE	SILENCIEUX	NON	TP-OV70
<b>Z 750 / S 04-06 (ZR750J)</b>						
	OK 7069 VSE	415 €	SOVE	SILENCIEUX	OUI	TP-OV70
	OK 7069 VSEB	439 €	XOVE	SILENCIEUX	OUI	TP-OV70
	XK 7369 V	319 €	L2X	SILENCIEUX	NON	NO
<b>Z 750 S / R 07-12 (ZR750L)</b>						
	FK 7871 SS	375 €	X55S	SILENCIEUX	OUI	TP-X55SS
	OK 7071 VSE	429 €	SOVE	SILENCIEUX	OUI	TP-OV70
	XK 7371 V	319 €	L2X	SILENCIEUX	NON	NO
	XK 7371 XB	449 €	L3XB	SILENCIEUX	OUI	TP-HP4
<b>ZXR 750 91-95 (ZX750L)</b>						
	OK 7063 VSE	345 €	SOVE	SILENCIEUX	OUI	TP-OV70
<b>ZX-7 R NINJA 96-99 (ZX750P)</b>						
	OK 7065 VSE	345 €	SOVE	SILENCIEUX	OUI	TP-OV70
<b>W800</b>						
	OK 760 SS	659 €	OVC13	LIGNE COMPLÈTE (2-1)	NON	TP-OV3
<b>Z 800 13-16 (ZR800A,ZR800B)</b>						
	FK 7868 SSB	419 €	X55SB	SILENCIEUX	OUI	TP-X55SS
	KIT 7168 C1	578 €	DKAT	DKAT - COLECTEUR	NON	NO
	OK 7068 VSE	429 €	SOVE	SILENCIEUX	OUI	TP-OV70
	OK 768 RRB	465 €	RC1B	SILENCIEUX	OUI	TP-OVC12
	XK 7368 XB	449 €	L3XB	SILENCIEUX	OUI	TP-HP4
<b>Z 800 e 13-16 (ZR800C,ZR800D)</b>						
	FK 7862 SSB	419 €	X55SB	SILENCIEUX	OUI	TP-X55SS
	OK 7062 VSE	429 €	SOVE	SILENCIEUX	OUI	TP-OV70
	OK 762 RRB	465 €	RC1B	SILENCIEUX	OUI	TP-OVC12
	XK 7362 XB	449 €	L3XB	SILENCIEUX	OUI	TP-HP4
<b>Z 900 FULL 16-19 (ZR900B)</b>						
	CK 7272 RC	329 €	RC	SILENCIEUX	OUI	NO
	FK 7172 SS	865 €	X55S	LIGNE COMPLÈTE (Z CUP)	NON	TP-X55SS
	FK 7872 SSB	445 €	X55SB	SILENCIEUX	OUI	TP-X55SS
	KIT 7172 C1	579 €	DKAT	DKAT - COLECTEUR	NON	NO



	REFERENCE	PRIX	GAMME	DESCRIPTION	CE	INTÉRIEUR
	OK 7072 VSE	439 €	SOVE	SILENCIEUX	OUI	TP-OV70
	OK 772 RRB	465 €	RC1B	SILENCIEUX	OUI	TP-OVC12
	SK 7772 C	1.045 €	SX1	LIGNE COMPLÈTE	OUI	TP-OV6
	XK 7372 XB	489 €	L3XB	SILENCIEUX	OUI	TP-HP4
<b>Z 900 FULL 2020 (ZR900F)</b>						
	CK 7258 RC	329 €	RC	SILENCIEUX	OUI	TP-OVC12
	KIT 7158 C1	579 €	DKAT	DKAT - COLECTEUR	NON	NO
	OK 7258 RRB	465 €	RC1B	SILENCIEUX	OUI	TP-OVC12
	SK 7772 C	1.045 €	SX1	LIGNE COMPLÈTE	OUI	TP-OV6
	XK 7258 XN	449 €	L3N	SILENCIEUX	OUI	TP-HP2
<b>Z 900 A2 17-19 (ZR900D,ZR900DA2)</b>						
	CK 7272 RC	329 €	RC	SILENCIEUX	OUI	NO
	FK 7872 SSB	445 €	X55SB	SILENCIEUX	OUI	TP-X55SS
	KIT 7173 C1	579 €	DKAT	DKAT - COLECTEUR	NON	NO
	OK 7072 VSE	439 €	SOVE	SILENCIEUX	OUI	TP-OV70
	OK 772 RRB	465 €	RC1B	SILENCIEUX	OUI	TP-OVC12
	XK 7372 XB	489 €	L3XB	SILENCIEUX	OUI	TP-HP4
<b>Z 900 A2 2020 (ZR900H,ZR900HA2)</b>						
	CK 7272 RC	329 €	RC	SILENCIEUX	OUI	NO
	FK 7872 SSB	445 €	X55SB	SILENCIEUX	OUI	TP-X55SS
	KIT 7173 C1	579 €	DKAT	DKAT - COLECTEUR	NON	NO
	OK 7072 VSE	439 €	SOVE	SILENCIEUX	OUI	TP-OV70
	OK 772 RRB	465 €	RC1B	SILENCIEUX	OUI	TP-OVC12
	XK 7372 XB	472 €	L3XB	SILENCIEUX	OUI	TP-HP4
<b>Z 900 RS 18-19 (ZR900C)</b>						
	KIT 7170 C1	579 €	DKAT	DKAT - COLECTEUR	NON	NO
	OK 770 RR	435 €	RC1	SILENCIEUX	OUI	TP-OVC12
	OK 770 RRB	465 €	RC1B	SILENCIEUX	OUI	TP-OVC12
<b>ZX-9 R NINJA 94-97 (ZX900B)</b>						
	OK 7083 VSE	415 €	SOVE	SILENCIEUX	OUI	TP-OV70
<b>ZX-9 R NINJA 98-01 (ZX900C)</b>						
	OK 7087 VSE	345 €	SOVE	SILENCIEUX	OUI	TP-OV70

	REFERENCE	PRIX	GAMME	DESCRIPTION	CE	INTÉRIEUR
	OK 7087 VSEB	375 €	XOVE	SILENCIEUX	OUI	TP-OV70
<b>Z 1000 03-06 (ZRT00A)</b>						
	OK 7195 VSE	565 €	SOVE	SILENCIEUX (2 EN 1)	OUI	TP-OV70
	OK 7195 VSEB	619 €	XOVE	SILENCIEUX (2 EN 1)	OUI	TP-OV70
<b>Z 1000 07-09 (ZRT00B)</b>						
	OK 7078 VSE	429 €	SOVE	SILENCIEUX (COTÉ DROIT)	NON	TP-OV70
	OK 7079 VSE	429 €	SOVE	SILENCIEUX (COTÉ GAUCHE)	NON	TP-OV70
	XK 7378 XB	449 €	L3XB	SILENCIEUX (COTÉ DROIT)	NON	TP-HP4
	XK 7379 XB	449 €	L3XB	SILENCIEUX (COTÉ GAUCHE)	NON	TP-HP4
<b>Z 1000 / Z 1000 SX 10-19 (ZRT00D,E,F,H / ZXT00G,L,W)</b>						
	FK 7874 S2	899 €	X55SP	LIGNE COMPLÈTE	NON	TP-X55SS
	FK 7874 SS	375 €	X55S	SILENCIEUX (COTÉ DROIT)	OUI	TP-X55SS
	FK 7874 SSB	419 €	X55SB	SILENCIEUX (COTÉ DROIT)	OUI	TP-X55SS
	FK 7875 SS	375 €	X55S	SILENCIEUX (COTÉ GAUCHE)	OUI	TP-X55SS
	FK 7875 SSB	419 €	X55SB	SILENCIEUX (COTÉ GAUCHE)	OUI	TP-X55SS
	OK 7074 VSE	415 €	SOVE	SILENCIEUX (COTÉ DROIT)	OUI	TP-OV70
	OK 7075 VSE	415 €	SOVE	SILENCIEUX (COTÉ GAUCHE)	OUI	TP-OV70
	OK 774 RRB	465 €	RC1B	SILENCIEUX (COTÉ DROIT)	OUI	TP-OVC12
	OK 775 RRB	465 €	RC1B	SILENCIEUX (COTÉ GAUCHE)	OUI	TP-OVC12
	SK 7774 C	1.045 €	SX1	LIGNE COMPLÈTE	OUI	TP-OV6
	XK 7374 V	319 €	L2X	SILENCIEUX (COTÉ DROIT)	OUI	NO
	XK 7375 V	319 €	L2X	SILENCIEUX (COTÉ GAUCHE)	OUI	NO
<b>ZX 10 R 04-05 (ZRT00C)</b>						
	OK 7297 VSE	345 €	SOVE	SILENCIEUX	OUI	TP-OV70
<b>ZX 10 R 08-10 (ZXT00E)</b>						
	KIT 7199 C1	89 €	DKAT	DKAT - TUBE RACCORD	NON	NO
	OK 7199 VSE	415 €	SOVE	SILENCIEUX	NON	TP-OV70
	XK 7399 V	299 €	L2X	SILENCIEUX	NON	NO
<b>ZX 10 R 11-19</b>						
	CK 7290 RC	329 €	RC	SILENCIEUX	NON	NO
	KIT 7090 C1	155 €	DKAT	DKAT - TUBE RACCORD	NON	NO
	OK 7090 VSE	415 €	SOVE	SILENCIEUX	NON	TP-OV70

















	REFERENCE	PRIX	GAMME	DESCRIPTION	CE	INTÉRIEUR
	OK 7590 VTR	599 €	VTI	SILENCIEUX (SBK EDITION)	NON	NO
<b>H2 15-18</b>						
	FK 7896 S2	745 €	X55SP	SILENCIEUX	NON	TP-X55SS
	OK 7096 VSE	415 €	SOVE	SILENCIEUX	NON	TP-OV70
<b>H2 SX / SX SE 18-19</b>						
	OK 782 RR	435 €	RC1	SILENCIEUX	NON	TP-OVC12
<b>VERSYS 1000 12-19 (LZT00A, LZT00B)</b>						
	OK 7084 VSE	415 €	SOVE	SILENCIEUX	OUI	TP-OV70
	OK 7084 VSEB	439 €	XOVE	SILENCIEUX	OUI	TP-OV70
	SK 7774 C	1.045 €	SX1	LIGNE COMPLÈTE	OUI	TP-OV6
<b>ZRX 1100 / ZRX 1100 II (ZRT10C)</b>						
	OK 7085 VSE	345 €	SOVE	SILENCIEUX	OUI	TP-OV70
	OK 7085 VSEB	375 €	XOVE	SILENCIEUX	OUI	TP-OV70
<b>ZX-12R NINJA (ZXT20A)</b>						
	OK 7091 VSE	345 €	SOVE	SILENCIEUX	OUI	TP-OV70
<b>ZZR 1200 02-03</b>						
	OK 7092 VSE	415 €	SOVE	SILENCIEUX (COTÉ DROIT)	NON	TP-OV70
	OK 7093 VSE	415 €	SOVE	SILENCIEUX (COTÉ GAUCHE)	NON	TP-OV70
<b>ZRX 1200 S / R 01-07 (ZRT20A)</b>						
	OK 7089 VSE	345 €	SOVE	SILENCIEUX	NON	TP-OV70
	OK 7089 VSEB	375 €	XOVE	SILENCIEUX	NON	TP-OV70
<b>ZZR 1400 06-07 (ZXT40A, ZXT40C)</b>						
	OK 7177 VSE	415 €	SOVE	SILENCIEUX (2 EN 1)	NON	TP-OV70
<b>ZZR 1400 08-11</b>						
	OK 7176 VSE	415 €	SOVE	SILENCIEUX (SEUL COTÉ DROIT)	NON	TP-OV70
<b>ZZR 1400 '12-13</b>						
	OK 7186 VSE	415 €	SOVE	SILENCIEUX (SEUL COTÉ DROIT)	NON	TP-OV70
	OK 7286 VSE	819 €	SOVE	SILENCIEUX (COTÉ DROIT & GAUCHE)	NON	TP-OV70
<b>ZX-14 R '12-13</b>						
	OK 7286 VSE	819 €	SOVE	SILENCIEUX (COTÉ DROIT & GAUCHE)	NON	TP-OV70
<b>GTR 1400 10-14</b>						
	OK 7088 VSE	415 €	SOVE	SILENCIEUX	NON	TP-OV70
<b>KTM</b>						
<b>DUKE 125 / 200 11-16</b>						
	OM 3050 VSE	565 €	SOVE	SILENCIEUX	NON	TP-OV70
	XM 3350 XB	519 €	L3XB	SILENCIEUX	NON	TP-HP4



	REFERENCE	PRIX	GAMME	DESCRIPTION	CE	INTÉRIEUR
<b>DUKE / RC 125 17-19</b>						
	CM 3257 RC	329 €	RC	SILENCIEUX	OUI	NO
	OM 357 RRB	465 €	RC1B	SILENCIEUX	OUI	TP-OVC12
	XM 3257 XN	449 €	L3N	SILENCIEUX	OUI	TP-OVC12
	XM 3357 XB	449 €	L3XB	SILENCIEUX	OUI	TP-HP4
<b>DUKE / RC 390 17-19</b>						
	CM 3257 RC	329 €	RC	SILENCIEUX	OUI	NO
	KIT 3057 C1	155 €	DKAT	DKAT - TUBE RACCORD	NON	NO
	OM 357 RRB	465 €	RC1B	SILENCIEUX	OUI	TP-OVC12
	XM 3257 XN	449 €	L3N	SILENCIEUX	OUI	TP-OVC12
	XM 3357 XB	449 €	L3XB	SILENCIEUX	OUI	TP-HP4
<b>RC 125 / 200 15-16</b>						
	OM 3051 VSE	565 €	SOVE	SILENCIEUX	NON	TP-OV70
	XM 3351 XB	519 €	L3XB	SILENCIEUX	NON	TP-HP4
<b>DUKE 390 12-16</b>						
	OM 3052 VSE	565 €	SOVE	SILENCIEUX	NON	TP-OV70
	XM 3352 XB	519 €	L3XB	SILENCIEUX	NON	TP-HP4
<b>RC 390 15-16</b>						
	OM 3053 VSE	565 €	SOVE	SILENCIEUX	NON	TP-OV70
	XM 3353 XB	529 €	L3XB	SILENCIEUX	NON	TP-HP4
<b>DUKE 690 (KMT690) 12-16</b>						
	OM 3070 VSE	429 €	SOVE	SILENCIEUX	OUI	TP-OV70
	XM 3370 XB	449 €	L3XB	SILENCIEUX	OUI	TP-HP4
<b>DUKE 790 (KMT790) 18-19</b>						
	CM 3279 RC	329 €	RC	SILENCIEUX	OUI	NO
	OM 379 RRB	465 €	RC1B	SILENCIEUX	OUI	TP-OVC12
	XM 3279 XN	449 €	L3N	SILENCIEUX	OUI	TP-HP2
<b>DUKE 790 ADVENTURE 19-20</b>						
	CM 3278 RC	329 €	RC	SILENCIEUX	OUI	TP-OVC12
	OM 378 RRB	465 €	RC1B	SILENCIEUX	OUI	TP-OVC12
	XM 3278 XN	449 €	L3N	SILENCIEUX	OUI	TP-OVC12
<b>1090 ADVENTURE 17-19</b>						
	EM 3089 SS	565 €	MXT	SILENCIEUX	OUI	TP-MXT80



REFERENCE	PRIX	GAMME	DESCRIPTION	CE	INTÉRIEUR
<b>1190 ADVENTURE 13-16</b>					
 EM 3089 SS	565 €	MXT	SILENCIEUX	OUI	TP-MXT80
<b>1290 ADVENTURE 15-19</b>					
 EM 3089 SS	565 €	MXT	SILENCIEUX	OUI	TP-MXT80
<b>SUPERDUKE 1290 14-15</b>					
 DKAT KIT 3080 C1	155 €	DKAT	DKAT - TUBE RACCORD	NON	NO
 OM 3080 VSE	415 €	SOVE	SILENCIEUX	NON	TP-OV70
<b>SUPERDUKE 1290 R / GT 17-18</b>					
 CM 3282 RC	329 €	RC	SILENCIEUX	NON	NO

### KYMCO

<b>CXS CURIO 50</b>					
 K 301	145 €	SCCL	LIGNE COMPLÈTE	NON	NO
<b>DINK 50 L.C.</b>					
 K 304	125 €	SCCL	LIGNE COMPLÈTE	OUI	NO
<b>DJR / DJ WORLD 50</b>					
 K 301	145 €	SCCL	LIGNE COMPLÈTE	OUI	NO
<b>HEROISM 50</b>					
 K 304	125 €	SCCL	LIGNE COMPLÈTE	NON	NO
<b>SCOUT 50</b>					
 K 301	145 €	SCCL	LIGNE COMPLÈTE	NON	NO
<b>SNIPPER 50</b>					
 K 304	125 €	SCCL	LIGNE COMPLÈTE	NON	NO
<b>SPACER 50 / PEOPLE 50</b>					
 K 304	125 €	SCCL	LIGNE COMPLÈTE	NON	NO
<b>SUPER 9</b>					
 K 304	125 €	SCCL	LIGNE COMPLÈTE	NON	NO
<b>TOP BOY 50</b>					
 K 304	125 €	SCCL	LIGNE COMPLÈTE	NON	NO
<b>ZX 50</b>					
 K 301	145 €	SCCL	LIGNE COMPLÈTE	NON	NO
<b>COBRA 50 RACER / CROSS</b>					
 K 304	125 €	SCCL	LIGNE COMPLÈTE	NON	NO
<b>MXer 150 02-04</b>					
 AC 2412 EV	369 €	SOVE	LIGNE COMPLÈTE	NON	TP-OV70
<b>MXU 250 04-05 (L6)</b>					
 AC 2432 EV	439 €	SOVE	LIGNE COMPLÈTE	OUI	TP-OV70
<b>KXR 250 03-05 (L3)</b>					
 AC 2431 EV	439 €	SOVE	LIGNE COMPLÈTE	OUI	TP-OV70

REFERENCE	PRIX	GAMME	DESCRIPTION	CE	INTÉRIEUR
<b>XCITING 300</b>					
 XK 0330 XS	559 €	L5X	SILENCIEUX	NON	NO
<b>XCITING 400</b>					
 XK 0339 XS	559 €	L5X	SILENCIEUX	NON	NO
<b>AK 550 (E1-A3)</b>					
 XK 0350 XS	839 €	L5X	LIGNE COMPLÈTE	OUI	TP-OV3

### MACAL

<b>CY 50 - MINARELLI HORIZONTAL</b>					
 YAM 2326	125 €	SCCL	LIGNE COMPLÈTE	NON	NO

### MALAGUTI

<b>CENTRO 50 - MINARELLI HORIZONTAL</b>					
 YAM 2326	125 €	SCCL	LIGNE COMPLÈTE	NON	NO
<b>CIAK - MINARELLI HORIZONTAL</b>					
 YAM 2326	125 €	SCCL	LIGNE COMPLÈTE	NON	NO
<b>CROSSER - MINARELLI HORIZONTAL</b>					
 YAM 2326	125 €	SCCL	LIGNE COMPLÈTE	NON	NO
<b>F-10 JETLINE - MINARELLI HORIZONTAL</b>					
 YAM 2326	125 €	SCCL	LIGNE COMPLÈTE	NON	NO
<b>F-12 PHANTOM L.C. - MINARELLI HORIZONTAL</b>					
 YAM 2326	125 €	SCCL	LIGNE COMPLÈTE	NON	NO
<b>F15 FIREFOX - MINARELLI HORIZONTAL</b>					
 YAM 2326	125 €	SCCL	LIGNE COMPLÈTE	NON	NO
<b>MBK</b>					
<b>BOOSTER - MINARELLI VERTICAL</b>					
 YAM 2334	125 €	SCCL	LIGNE COMPLÈTE	NON	NO
<b>EVOLIS - MINARELLI HORIZONTAL</b>					
 YAM 2326	125 €	SCCL	LIGNE COMPLÈTE	NON	NO
<b>FIZZ 50 - MINARELLI HORIZONTAL</b>					
 YAM 2326	125 €	SCCL	LIGNE COMPLÈTE	NON	NO
<b>FLIPPER - MINARELLI HORIZONTAL</b>					
 YAM 2326	125 €	SCCL	LIGNE COMPLÈTE	NON	NO
<b>FORTE 50 - MINARELLI HORIZONTAL</b>					
 YAM 2326	125 €	SCCL	LIGNE COMPLÈTE	NON	NO
<b>NEXT GENERATION 50 - MINARELLI VERTICAL</b>					
 YAM 2334	125 €	SCCL	LIGNE COMPLÈTE	NON	NO
<b>NITRO 50 - MINARELLI HORIZONTAL</b>					
 YAM 2326	125 €	SCCL	LIGNE COMPLÈTE	NON	NO



REFERENCE	PRIX	GAMME	DESCRIPTION	CE	INTÉRIEUR
-----------	------	-------	-------------	----	-----------

#### OVETTO - MINARELLI VERTICAL

	YAM 2334	125 €	SCCL	LIGNE COMPLÈTE	NON	NO
---	----------	-------	------	----------------	-----	----

#### SORRISO 50 - MINARELLI VERTICAL

	YAM 2334	125 €	SCCL	LIGNE COMPLÈTE	NON	NO
---	----------	-------	------	----------------	-----	----

#### STUNT - MINARELLI VERTICAL



	YAM 2334	125 €	SCCL	LIGNE COMPLÈTE	NON	NO
---	----------	-------	------	----------------	-----	----

#### TARGET 50 - MINARELLI VERTICAL

	YAM 2334	125 €	SCCL	LIGNE COMPLÈTE	NON	NO
---	----------	-------	------	----------------	-----	----

### MONDIAL

#### HPS 125 / 150





	KIT 019 C1	155 €	DKAT	DKAT - COLECTEUR	NON	NO
	OA 619 RR	435 €	RC1	SILENCIEUX	OUI	TP-OVC12
	XA 0319 V	369 €	L2X	SILENCIEUX	OUI	NO

### MOTO GUZZI

#### V7 II

	OM 334 SSB	319 €	OVC11SB	SILENCIEUX (COTÉ DROIT)	NON	TP-OV3
	OM 334 SSS	279 €	OVC11SS	SILENCIEUX (COTÉ DROIT)	NON	TP-OV3
	OM 335 SSB	319 €	OVC11SB	SILENCIEUX (COTÉ GAUCHE)	NON	TP-OV3
	OM 335 SSS	279 €	OVC11SS	SILENCIEUX (COTÉ GAUCHE)	NON	TP-OV3

#### V7 III

	OM 332 SSB	319 €	OVC11SB	SILENCIEUX (COTÉ DROIT)	NON	TP-OV3
	OM 332 SSS	279 €	OVC11SS	SILENCIEUX (COTÉ DROIT)	NON	TP-OV3
	OM 333 SSB	319 €	OVC11SB	SILENCIEUX (COTÉ GAUCHE)	NON	TP-OV3
	OM 333 SSS	279 €	OVC11SS	SILENCIEUX (COTÉ GAUCHE)	NON	TP-OV3

### PEUGEOT

#### BUXY 50 <98

	P 234	145 €	SCCL	LIGNE COMPLÈTE	NON	NO
---	-------	-------	------	----------------	-----	----

#### BUXY 50 98>

	P 230	125 €	SCCL	LIGNE COMPLÈTE	NON	NO
---	-------	-------	------	----------------	-----	----

#### ELYSEO 50

	P 230	125 €	SCCL	LIGNE COMPLÈTE	NON	NO
---	-------	-------	------	----------------	-----	----

#### LUDIX 50 ONE AIR

	P 235	125 €	SCCL	LIGNE COMPLÈTE	NON	NO
---	-------	-------	------	----------------	-----	----

#### LUDIX 50 CLASSIC AIR

	P 235	125 €	SCCL	LIGNE COMPLÈTE	NON	NO
---	-------	-------	------	----------------	-----	----

REFERENCE	PRIX	GAMME	DESCRIPTION	CE	INTÉRIEUR
-----------	------	-------	-------------	----	-----------

#### SPEEDFIGHT I 50 AIR / L.C.

	P 230	125 €	SCCL	LIGNE COMPLÈTE	OUI	NO
---	-------	-------	------	----------------	-----	----

#### SPEEDAKE 50

	P 230	125 €	SCCL	LIGNE COMPLÈTE	NON	NO
---	-------	-------	------	----------------	-----	----

#### SPEEDFIGHT II 50 L.C.

	P 230	125 €	SCCL	LIGNE COMPLÈTE	NON	NO
---	-------	-------	------	----------------	-----	----

#### SQUAB 50

	P 230	125 €	SCCL	LIGNE COMPLÈTE	NON	NO
---	-------	-------	------	----------------	-----	----

#### ST 50 - 50 RAPIDO

	HP 1951	145 €	SCCL	LIGNE COMPLÈTE	NON	NO
---	---------	-------	------	----------------	-----	----

#### TREKKER 50

	P 230	125 €	SCCL	LIGNE COMPLÈTE	OUI	NO
---	-------	-------	------	----------------	-----	----

#### VIVA CITY 50

	P 230	125 €	SCCL	LIGNE COMPLÈTE	OUI	NO
---	-------	-------	------	----------------	-----	----

#### ZENITH 50 <98

	P 234	145 €	SCCL	LIGNE COMPLÈTE	NON	NO
---	-------	-------	------	----------------	-----	----

#### ZENITH 50 98>

	P 230	125 €	SCCL	LIGNE COMPLÈTE	NON	NO
---	-------	-------	------	----------------	-----	----

### PIAGGIO

#### PIAGGIO EXTREME

	V 280	125 €	SCCL	LIGNE COMPLÈTE	NON	NO
---	-------	-------	------	----------------	-----	----

#### PIAGGIO FREE 50

	V 280	125 €	SCCL	LIGNE COMPLÈTE	NON	NO
---	-------	-------	------	----------------	-----	----

#### PIAGGIO ZIP 50 2T <'08

	V 280	125 €	SCCL	LIGNE COMPLÈTE	NON	NO
---	-------	-------	------	----------------	-----	----

#### PIAGGIO ZIP 50 2T 09-10

	V 280	125 €	SCCL	LIGNE COMPLÈTE	NON	NO
---	-------	-------	------	----------------	-----	----

#### PIAGGIO LIBERTY 50

	V 280	125 €	SCCL	LIGNE COMPLÈTE	NON	NO
---	-------	-------	------	----------------	-----	----

#### PIAGGIO NRG/MC2/MC3

	V 280	125 €	SCCL	LIGNE COMPLÈTE	OUI	NO
---	-------	-------	------	----------------	-----	----

#### PIAGGIO NTT 50

	V 280	125 €	SCCL	LIGNE COMPLÈTE	NON	NO
---	-------	-------	------	----------------	-----	----

#### PIAGGIO STORM 50

	V 280	125 €	SCCL	LIGNE COMPLÈTE	NON	NO
---	-------	-------	------	----------------	-----	----

#### PIAGGIO TYPHOON 50

	V 280	125 €	SCCL	LIGNE COMPLÈTE	NON	NO
---	-------	-------	------	----------------	-----	----

### RIEJU



REFERENCE	PRIX	GAMME	DESCRIPTION	CE	INTÉRIEUR
-----------	------	-------	-------------	----	-----------

#### F-10 - MINARELLI HORIZONTAL

	YAM 2326	125 €	SCCL	LIGNE COMPLÈTE	NON	NO
---	----------	-------	------	----------------	-----	----

#### FIRST / WINDY 50 - MINARELLI HORIZONTAL

	YAM 2326	125 €	SCCL	LIGNE COMPLÈTE	NON	NO
---	----------	-------	------	----------------	-----	----

#### RS-3 125

	OR 3100 VSE	415 €	SOVE	SILENCIEUX	NON	TP-OV70
---	-------------	-------	------	------------	-----	---------

#### CENTURY 125 17-19

	KIT 019 C1	155 €	DKAT	DKAT - COLECTEUR	NON	NO
---	------------	-------	------	------------------	-----	----

	OA 619 RR	435 €	RC1	SILENCIEUX	NON	TP-OVC12
---	-----------	-------	-----	------------	-----	----------

	XA 0319 V	369 €	L2X	SILENCIEUX	NON	NO
---	-----------	-------	-----	------------	-----	----

### ROYAL ENFIELD

#### BULLET 350 - 500

	HR 5003 SB	469 €	HC2-2B	SILENCIEUX	NON	TP-OV3
---	------------	-------	--------	------------	-----	--------

	HR 5003 SC	489 €	HC2-2C	SILENCIEUX	NON	TP-OV3
---	------------	-------	--------	------------	-----	--------

### SIAMOTO

#### BIRDIE 50 - MINARELLI HORIZONTAL

	YAM 2326	125 €	SCCL	LIGNE COMPLÈTE	NON	NO
---	----------	-------	------	----------------	-----	----

#### MAT 50 - MINARELLI HORIZONTAL

	YAM 2326	125 €	SCCL	LIGNE COMPLÈTE	NON	NO
---	----------	-------	------	----------------	-----	----

#### SCROSS - FRANCO MORINI

	SZ 2820	145 €	SCCL	LIGNE COMPLÈTE	NON	NO
---	---------	-------	------	----------------	-----	----

#### TOP RACING 50 -MINARELLI HORIZONTAL

	YAM 2326	125 €	SCCL	LIGNE COMPLÈTE	NON	NO
---	----------	-------	------	----------------	-----	----

### SUZUKI

#### KATANA 50 / R

	SZ 2822	125 €	SCCL	LIGNE COMPLÈTE	NON	NO
---	---------	-------	------	----------------	-----	----

#### ADDRESS 50 / R - FRANCO MORINI

	SZ 2820	145 €	SCCL	LIGNE COMPLÈTE	NON	NO
---	---------	-------	------	----------------	-----	----

#### ESTILETE 50

	SZ 2822	125 €	SCCL	LIGNE COMPLÈTE	NON	NO
---	---------	-------	------	----------------	-----	----

#### ZILLION 50

	SZ 2822	125 €	SCCL	LIGNE COMPLÈTE	NON	NO
---	---------	-------	------	----------------	-----	----

#### VAN VAN 125

	OS 8015 VSE	415 €	SOVE	SILENCIEUX	NON	TP-OV70
---	-------------	-------	------	------------	-----	---------

#### GSX-S 125 17-19 (WDL0)

	OS 812 RR	619 €	RC1	LIGNE COMPLÈTE	OUI	TP-OVC12
---	-----------	-------	-----	----------------	-----	----------

	OS 812 RRB	639 €	RC1B	LIGNE COMPLÈTE	OUI	TP-OVC12
---	------------	-------	------	----------------	-----	----------

254

REFERENCE	PRIX	GAMME	DESCRIPTION	CE	INTÉRIEUR
-----------	------	-------	-------------	----	-----------

#### GSX-R 125 17-19 (WDL0)

	OS 812 RR	619 €	RC1	LIGNE COMPLÈTE	OUI	TP-OVC12
---	-----------	-------	-----	----------------	-----	----------

	OS 812 RRB	639 €	RC1B	LIGNE COMPLÈTE	OUI	TP-OVC12
---	------------	-------	------	----------------	-----	----------

#### INAZUMA GW 250 12-15

	OS 8122 VSE	415 €	SOVE	LIGNE COMPLÈTE (2 EN 1)	NON	TP-OV70
---	-------------	-------	------	-------------------------	-----	---------

	XS 8322 XB	449 €	L3XB	SILENCIEUX	NON	TP-HP4
---	------------	-------	------	------------	-----	--------

	XS 8323 XB	449 €	L3XB	SILENCIEUX	NON	TP-HP4
---	------------	-------	------	------------	-----	--------

#### GSX-R 250 17-19

	OS 835 RRB	465 €	RC1B	SILENCIEUX	NON	TP-OVC12
---	------------	-------	------	------------	-----	----------

#### DL 250 V-STROM 17-19

	OS 835 RRB	465 €	RC1B	SILENCIEUX	NON	TP-OVC12
---	------------	-------	------	------------	-----	----------

#### LTZ 400 QUADSPORT 03-04

	AS 8425 EV	415 €	SOVE	SILENCIEUX	NON	TP-OV70
---	------------	-------	------	------------	-----	---------

#### GSF 400 N BANDIT (GK75B)

	OS 8021 VSE	415 €	SOVE	SILENCIEUX	NON	TP-OV70
---	-------------	-------	------	------------	-----	---------

#### GS 500 E <03 (GM51A,GM51B)

	OS 8031 VSE	415 €	SOVE	SILENCIEUX	OUI	TP-OV70
---	-------------	-------	------	------------	-----	---------

#### GS 500 F 04-10 (BK)

	OS 8031 VSE	415 €	SOVE	SILENCIEUX	OUI	TP-OV70
---	-------------	-------	------	------------	-----	---------

#### GSF 600 N BANDIT 94-00 (GN77A)

	OS 8045 VSE	415 €	SOVE	SILENCIEUX	OUI	TP-OV70
---	-------------	-------	------	------------	-----	---------

	OS 8045 VSEB	439 €	XOVE	SILENCIEUX	OUI	TP-OV70
---	--------------	-------	------	------------	-----	---------

#### GSF 600 N BANDIT 01-04 (WVA8)

	OS 8051 VSE	415 €	SOVE	SILENCIEUX	OUI	TP-OV70
---	-------------	-------	------	------------	-----	---------

	OS 8051 VSEB	439 €	XOVE	SILENCIEUX	OUI	TP-OV70
---	--------------	-------	------	------------	-----	---------

#### GSX 600 F 88-97 (GN72A)

	OS 8043 VSE	565 €	SOVE	SILENCIEUX (2 EN 1)	OUI	TP-OV70
---	-------------	-------	------	---------------------	-----	---------

#### GSX 600 F 98-05 (AJ)

	OS 8047 VSE	415 €	SOVE	SILENCIEUX	OUI	TP-OV70
---	-------------	-------	------	------------	-----	---------

	OS 8047 VSEB	439 €	XOVE	SILENCIEUX	OUI	TP-OV70
---	--------------	-------	------	------------	-----	---------

#### GSX 600 R SRAD 97-00 (AD)

	OS 8063 VSE	345 €	SOVE	SILENCIEUX	NON	TP-OV70
---	-------------	-------	------	------------	-----	---------

























#### GSX 600 R 01-05 (BG)

	OS 8067 VSE	345 €	SOVE	SILENCIEUX	OUI	TP-OV70
---	-------------	-------	------	------------	-----	---------

	OS 8067 VSEB	375 €	XOVE	SILENCIEUX	OUI	TP-OV70
---	--------------	-------	------	------------	-----	---------

























REFERENCE	PRIX	GAMME	DESCRIPTION	CE	INTÉRIEUR
<b>GSX 600 R 06-07 (CE1)</b>					
 OS 8068 VSE	415 €	SOVE	SILENCIEUX	NON	TP-OV70
<b>GSX 600 R 08-10 (CV1)</b>					
 OS 8069 VSE	415 €	SOVE	SILENCIEUX	NON	TP-OV70
 XS 8369 V	311 €	L2X	SILENCIEUX	NON	NO
<b>GSX 600 R 11-15</b>					
 OS 8064 VSE	415 €	SOVE	SILENCIEUX	NON	TP-OV70
 XS 8364 V	299 €	L2X	SILENCIEUX	NON	NO
<b>SV 650 / SV 650 S 99-03 (AV) (AY*)</b>					
 OS 8049 VSE	415 €	SOVE	SILENCIEUX	OUI	TP-OV70
<b>SV 650 / S 04-05 (WVBY)</b>					
 OS 8254 VSE	415 €	SOVE	SILENCIEUX	OUI	TP-OV70
 OS 8254 VSEB	439 €	XOVE	SILENCIEUX	OUI	TP-OV70
<b>SV 650 S 06-12</b>					
 OS 8056 VSE	429 €	SOVE	SILENCIEUX	OUI	TP-OV70
 OS 8056 VSEB	529 €	XOVE	SILENCIEUX	OUI	TP-OV70
<b>SV 650 S 16-19 (WCX0)</b>					
 OS 8033 VSE	415 €	SOVE	SILENCIEUX	OUI	TP-OV70
 OS 8033 VSEB	439 €	XOVE	SILENCIEUX	OUI	TP-OV70
 XS 8333 XB	439 €	L3XB	SILENCIEUX	OUI	TP-HP4
<b>SV 650 X 16-19 (WCX1)</b>					
 OS 8033 VSE	415 €	SOVE	SILENCIEUX	OUI	TP-OV70
 OS 8033 VSEB	439 €	XOVE	SILENCIEUX	OUI	TP-OV70
 XS 8333 XB	449 €	L3XB	SILENCIEUX	OUI	TP-HP4
<b>SFV 650 GLADIUS 09-15 (WVCX)</b>					
 FS 8858 SS	375 €	X55S	SILENCIEUX	OUI	TP-X55SS
 OS 8058 VSE	415 €	SOVE	SILENCIEUX	OUI	TP-OV70
 XS 8358 V	287 €	L2X	SILENCIEUX	OUI	NO
<b>GSF 650 N / S BANDIT 07-15 (WVCZ)</b>					
 OS 8057 VSE	422 €	SOVE	SILENCIEUX	OUI	TP-OV70
 OS 8057 VSEB	513 €	XOVE	SILENCIEUX	OUI	TP-OV70
 XS 8357 XB	449 €	L3XB	SILENCIEUX	OUI	TP-HP4
<b>GSX 650 F 08-15 (WVCJ)</b>					
 OS 8057 VSE	422 €	SOVE	SILENCIEUX	OUI	TP-OV70

REFERENCE	PRIX	GAMME	DESCRIPTION	CE	INTÉRIEUR
 OS 8057 VSEB	513 €	XOVE	SILENCIEUX	OUI	TP-OV70
 XS 8357 XB	449 €	L3XB	SILENCIEUX	OUI	TP-HP4
<b>V-STROM 650 04-16</b>					
 OS 8059 VSE	659 €	SOVE	LIGNE COMPLÈTE	NON	TP-OV70
<b>V-STROM DL 650 17-19</b>					
 ES 8052 SS	565 €	MXT	SILENCIEUX	NON	TP-MXT80
<b>GSR 750 11-16 (C5)</b>					
 FS 8862 SS	375 €	X55S	SILENCIEUX	OUI	TP-X55SS
 OS 8062 VSE	415 €	SOVE	SILENCIEUX	OUI	TP-OV70
 OS 8062 VSEB	439 €	XOVE	SILENCIEUX	OUI	TP-OV70
 OS 8062 VTI	619 €	VTI	SILENCIEUX	OUI	TP-OV3
 OS 862 RRB	465 €	RC1B	SILENCIEUX	OUI	TP-OVC12
 XS 8262 XN	449 €	L3XB	SILENCIEUX	OUI	TP-HP4
 XS 8362 XB	449 €	L3XB	SILENCIEUX	OUI	TP-HP4
<b>GSX-S 750 17-19 (C5)</b>					
 FS 8862 SS	375 €	X55S	SILENCIEUX	OUI	TP-X55SS
 OS 8062 VSE	415 €	SOVE	SILENCIEUX	OUI	TP-OV70
 OS 8062 VSEB	439 €	XOVE	SILENCIEUX	OUI	TP-OV70
 OS 8062 VTI	619 €	VTI	SILENCIEUX	OUI	TP-OV3
 OS 862 RRB	465 €	RC1B	SILENCIEUX	OUI	TP-OVC12
 XS 8262 XN	449 €	L3XB	SILENCIEUX	OUI	TP-HP4
 XS 8362 XB	449 €	L3XB	SILENCIEUX	OUI	TP-HP4
<b>GSX 750 NAKED 97-03 (AE)</b>					
 OS 8065 VSE	415 €	SOVE	SILENCIEUX	OUI	TP-OV70
<b>GSX 750 F 88-97 (GR78A)</b>					
 OS 8043 VSE	565 €	SOVE	SILENCIEUX (2 EN 1)	OUI	TP-OV70
<b>GSX 750 F 98-05 (AK)</b>					
 OS 8047 VSE	415 €	SOVE	SILENCIEUX	OUI	TP-OV70
 OS 8047 VSEB	439 €	XOVE	SILENCIEUX	OUI	TP-OV70
<b>GSX 750 R 90-91 (GR7AD)</b>					
 OS 8060 VSE	415 €	SOVE	SILENCIEUX	NON	TP-OV70
<b>GSX 750 RW 92-95 (GR7BD)</b>					
 OS 8061 VSE	565 €	SOVE	SILENCIEUX (2 EN 1)	OUI	TP-OV70





REFERENCE	PRIX	GAMME	DESCRIPTION	CE	INTÉRIEUR
<b>GSX 750 R SRAD 96-99 (GR7DD)</b>					
 OS 8063 VSE	345 €	SOVE	SILENCIEUX	NON	TP-OV70
<b>GSX 750 R 00-05 (BD)</b>					
 OS 8067 VSE	345 €	SOVE	SILENCIEUX	OUI	TP-OV70
 OS 8067 VSEB	375 €	XOVE	SILENCIEUX	OUI	TP-OV70
<b>GSX 750 R 06-07 (CF)</b>					
 OS 8068 VSE	415 €	SOVE	SILENCIEUX	NON	TP-OV70
<b>GSX 750 R 08-10 (CW1)</b>					
 OS 8069 VSE	415 €	SOVE	SILENCIEUX	NON	TP-OV70
 XS 8369 V	319 €	L2X	SILENCIEUX	NON	NO
<b>GSX 750 R 11-15</b>					
 OS 8064 VSE	415 €	SOVE	SILENCIEUX	NON	TP-OV70
 XS 8364 V	299 €	L2X	SILENCIEUX	NON	NO
<b>RF 900 R (GT73D)</b>					
 OS 8081 VSE	345 €	SOVE	SILENCIEUX	OUI	TP-OV70
<b>SV1000S / SV1000N 03-05 (BX)</b>					
 OS 8078 VSE	345 €	SOVE	SILENCIEUX (COTÉ DROIT)	OUI	TP-OV70
 OS 8078 VSEB	375 €	XOVE	SILENCIEUX (COTÉ DROIT)	OUI	TP-OV70
 OS 8079 VSE	345 €	SOVE	SILENCIEUX (COTÉ GAUCHE)	OUI	TP-OV70
 OS 8079 VSEB	375 €	XOVE	SILENCIEUX (COTÉ GAUCHE)	OUI	TP-OV70
<b>TL1000S 97-01 (AG)</b>					
 OS 8088 VSE	345 €	SOVE	SILENCIEUX (COTÉ DROIT)	NON	TP-OV70
 OS 8089 VSE	345 €	SOVE	SILENCIEUX (COTÉ GAUCHE)	NON	TP-OV70
<b>DL 1000 V-STROM 02-13</b>					
 OS 8070 VSE	415 €	SOVE	SILENCIEUX (COTÉ DROIT)	NON	TP-OV70
 OS 8071 VSE	415 €	SOVE	SILENCIEUX (COTÉ GAUCHE)	NON	TP-OV70
<b>DL 1000 V-STROM 14-19</b>					
 ES 8084 SS	565 €	MXT	SILENCIEUX	OUI	TP-MXT80
<b>GSX 1000 R 01-04 (WVBL)</b>					
 OS 8098 VSE	345 €	SOVE	SILENCIEUX	OUI	TP-OV70
<b>GSX 1000 R 05-06 (B6)</b>					
 OS 8094 VSE	429 €	SOVE	SILENCIEUX	NON	TP-OV70
<b>GSX 1000 R 07-08 (WVCL)</b>					
 OS 8176 VSE	429 €	SOVE	SILENCIEUX (SEUL COTÉ DROIT)	NON	TP-OV70
<b>GSX 1000 R 09-11 (WVCL)</b>					
 OS 8175 VSE	415 €	SOVE	SILENCIEUX (SEUL COTÉ DROIT)	NON	TP-OV70

REFERENCE	PRIX	GAMME	DESCRIPTION	CE	INTÉRIEUR
<b>GSX 1000 R 12-13</b>					
 OS 8080 VSE	415 €	SOVE	SILENCIEUX	NON	TP-OV70
<b>GSX 1000 R 17-19</b>					
 CS 8282 RC	329 €	RC	SILENCIEUX	NON	NO
 OS 882 RRB	465 €	RC1B	SILENCIEUX	NON	TP-OVC12
<b>GSX 1000 S / F 15-16</b>					
 CS 8299 RC	329 €	RC	SILENCIEUX	NON	NO
 SS 8799 C	999 €	SX1	LIGNE COMPLÈTE	OUI	TP-OV6
 XS 8399 V	330 €	L2X	SILENCIEUX	OUI	NO
<b>KATANA 1000 19-20</b>					
 CS 8299 RC	329 €	RC	SILENCIEUX	NON	NO
 SS 8799 C	999 €	SX1	LIGNE COMPLÈTE	NON	TP-OV6
 XS 8399 V	330 €	L2X	SILENCIEUX	NON	NO
<b>GSX 1200 INAZUMA 99-03 (A3)</b>					
 OS 8093 VSE	415 €	SOVE	SILENCIEUX	NON	TP-OV70
<b>GSF 1200 N BANDIT 96-99 (GV75A)</b>					
 OS 8085 VSE	345 €	SOVE	SILENCIEUX	OUI	TP-OV70
 OS 8085 VSEB	375 €	XOVE	SILENCIEUX	OUI	TP-OV70
<b>GSF 1200 N BANDIT 00-05 (WVA9)</b>					
 OS 8095 VSE	415 €	SOVE	SILENCIEUX	OUI	TP-OV70
 OS 8095 VSEB	439 €	XOVE	SILENCIEUX	OUI	TP-OV70
<b>GSF 1250 N BANDIT 07-15 (CH)</b>					
 OS 8092 VSE	429 €	SOVE	SILENCIEUX	OUI	TP-OV70
 OS 8092 VSEB	529 €	XOVE	SILENCIEUX	OUI	TP-OV70
 XS 8357 XB	449 €	L3XB	SILENCIEUX	OUI	TP-HP4
<b>GSX 1250 N 10-15</b>					
 OS 8092 VSE	429 €	SOVE	SILENCIEUX	OUI	TP-OV70
 OS 8092 VSEB	529 €	XOVE	SILENCIEUX	OUI	TP-OV70
 XS 8357 XB	449 €	L3XB	SILENCIEUX	OUI	TP-HP4
<b>GSX 1300 R HAYABUSA 99-07 (WVA1)</b>					
 OS 8090 VSE	345 €	SOVE	SILENCIEUX (COTÉ DROIT)	OUI	TP-OV70
 OS 8090 VSEB	375 €	XOVE	SILENCIEUX (COTÉ DROIT)	OUI	TP-OV70
 OS 8091 VSE	345 €	SOVE	SILENCIEUX (COTÉ GAUCHE)	OUI	TP-OV70
 OS 8091 VSEB	375 €	XOVE	SILENCIEUX (COTÉ GAUCHE)	OUI	TP-OV70





REFERENCE	PRIX	GAMME	DESCRIPTION	CE	INTÉRIEUR
-----------	------	-------	-------------	----	-----------

### GSX 1300 R HAYABUSA 08-16 (WVCK)

	OS 8072 VSE	345 €	SOVE	SILENCIEUX (COTÉ DROIT)	NON	TP-OV70
	OS 8073 VSE	345 €	SOVE	SILENCIEUX (COTÉ GAUCHE)	NON	TP-OV70

### GSX 1400 NAKED 01-04 (WVBN)

	OS 8096 VSE	415 €	SOVE	SILENCIEUX (COTÉ DROIT)	NON	TP-OV70
	OS 8097 VSE	415 €	SOVE	SILENCIEUX (COTÉ GAUCHE)	NON	TP-OV70

## SYM

### JET 50

	K 304	125 €	SCCL	LIGNE COMPLÈTE	NON	NO
---	-------	-------	------	----------------	-----	----

### JUNGLE 50

	K 304	125 €	SCCL	LIGNE COMPLÈTE	NON	NO
---	-------	-------	------	----------------	-----	----

### SUPERFANCY 50

	K 304	125 €	SCCL	LIGNE COMPLÈTE	NON	NO
---	-------	-------	------	----------------	-----	----

## TRIUMPH

### TT 600 00-02 (TH)

	OT 4041 VSE	345 €	SOVE	SILENCIEUX	OUI	TP-OV70
---	-------------	-------	------	------------	-----	---------

### DAYTONA 600 03-04

	OT 4041 VSE	345 €	SOVE	SILENCIEUX	NON	TP-OV70
---	-------------	-------	------	------------	-----	---------



### SPEEDFOUR 02-05

	OT 4041 VSE	345 €	SOVE	SILENCIEUX	NON	TP-OV70
---	-------------	-------	------	------------	-----	---------

### DAYTONA 650 05

	OT 4041 VSE	345 €	SOVE	SILENCIEUX	NON	TP-OV70
---	-------------	-------	------	------------	-----	---------



### STREET TRIPLE 675 07-11 (D67LD)

	OT 4044 VSE	345 €	SOVE	SILENCIEUX (COTÉ DROIT)	NON	TP-OV70
	OT 4045 VSE	345 €	SOVE	SILENCIEUX (COTÉ GAUCHE)	NON	TP-OV70



### STREET TRIPLE 675 13-16

	FT 4846 SSB	419 €	X55SB	SILENCIEUX	NON	TP-X55SS
---	-------------	-------	-------	------------	-----	----------



### TRIDENT 750/900 <99

	OT 4084 VSE	415 €	SOVE	SILENCIEUX (COTÉ DROIT)	NON	TP-OV70
	OT 4085 VSE	415 €	SOVE	SILENCIEUX (COTÉ GAUCHE)	NON	TP-OV70

### SPRINT <99



	OT 4084 VSE	415 €	SOVE	SILENCIEUX (COTÉ DROIT)	NON	TP-OV70
	OT 4085 VSE	415 €	SOVE	SILENCIEUX (COTÉ GAUCHE)	NON	TP-OV70

### TROPHY <96

	OT 4084 VSE	415 €	SOVE	SILENCIEUX (COTÉ DROIT)	NON	TP-OV70
	OT 4085 VSE	415 €	SOVE	SILENCIEUX (COTÉ GAUCHE)	NON	TP-OV70

REFERENCE	PRIX	GAMME	DESCRIPTION	CE	INTÉRIEUR
-----------	------	-------	-------------	----	-----------

### DAYTONA T357

	OT 4084 VSE	415 €	SOVE	SILENCIEUX (COTÉ DROIT)	NON	TP-OV70
	OT 4085 VSE	415 €	SOVE	SILENCIEUX (COTÉ GAUCHE)	NON	TP-OV70



### TIGER 800 - 800 XC 11-13 (A08)

	OT 4048 VSE	429 €	SOVE	SILENCIEUX	OUI	TP-OV70
---	-------------	-------	------	------------	-----	---------

### TIGER 800 16-19

	ET 4065 SS	565 €	MXT	SILENCIEUX	NON	TP-MXT80
---	------------	-------	-----	------------	-----	----------



### BONNEVILLE / T100

	OT 476 SSS	279 €	OVC11SS	SILENCIEUX (COTÉ DROIT)	NON	TP-OV3
	OT 477 SSS	279 €	OVC11SS	SILENCIEUX (COTÉ GAUCHE)	NON	TP-OV3



### BONNEVILLE NEWCHURCH / SE 15-16

	OT 464 SS	265 €	OVC11SS	SILENCIEUX (COTÉ DROIT)	NON	TP-OV3
	OT 464 SSB	319 €	OVC11SB	SILENCIEUX (COTÉ DROIT)	NON	TP-OV3
	OT 465 SS	265 €	OVC11SS	SILENCIEUX (COTÉ GAUCHE)	NON	TP-OV3
	OT 465 SSB	319 €	OVC11SB	SILENCIEUX (COTÉ GAUCHE)	NON	TP-OV3

### THRUXTON 865 04-15

	OT 470 SSS	279 €	OVC11SS	SILENCIEUX (COTÉ DROIT)	NON	TP-OV3
	OT 471 SSS	279 €	OVC11SS	SILENCIEUX (COTÉ GAUCHE)	NON	TP-OV3



### STREET TWIN 16-18

	OT 460 SS	265 €	OVC11SS	SILENCIEUX (COTÉ DROIT)	OUI	TP-OV3
	OT 461 SS	265 €	OVC11SS	SILENCIEUX (COTÉ GAUCHE)	OUI	TP-OV3



### T 955 i SPEED TRIPLE / DAYTONA 98-01 (TE)

	OT 4081 VSE	415 €	SOVE	SILENCIEUX	OUI	TP-OV70
---	-------------	-------	------	------------	-----	---------



### ST1050 SPEED TRIPLE 05-06 (515NJ)

	OT 4088 VSE	345 €	SOVE	SILENCIEUX (COTÉ DROIT)	NON	TP-OV70
	OT 4089 VSE	345 €	SOVE	SILENCIEUX (COTÉ GAUCHE)	NON	TP-OV70
	OT 4388 VSE	415 €	SOVE	SILENCIEUX (POSITION BASSE)	NON	TP-OV70

### ST1050 SPEED TRIPLE 07-10

	OT 4088 VSE	345 €	SOVE	SILENCIEUX (COTÉ DROIT)	NON	TP-OV70
	OT 4089 VSE	345 €	SOVE	SILENCIEUX (COTÉ GAUCHE)	NON	TP-OV70



### ST1050 SPEED TRIPLE 11-13 (515NV)

	OT 4090 VSE	345 €	SOVE	SILENCIEUX (COTÉ DROIT)	OUI	TP-OV70
	OT 4091 VSE	345 €	SOVE	SILENCIEUX (COTÉ GAUCHE)	OUI	TP-OV70
	OT 4390 VSE	415 €	SOVE	SILENCIEUX (POSITION BASSE)	NON	TP-OV70







REFERENCE	PRIX	GAMME	DESCRIPTION	CE	INTÉRIEUR
-----------	------	-------	-------------	----	-----------





### BONNEVILLE / T120 2016

 OT 462 SS	265 €	OVC11SS	SILENCIEUX (COTÉ DROIT)	OUI	TP-OV3
 OT 463 SS	265 €	OVC11SS	SILENCIEUX (COTÉ GAUCHE)	OUI	TP-OV3





### BOBBER 17-19

 OT 4068 SS	355 €	HC1-3S	SILENCIEUX (COTÉ DROIT)	NON	TP-OV3
 OT 4068 SSB	345 €	HC1-3SB	SILENCIEUX (COTÉ DROIT)	NON	TP-OV3
 OT 4069 SS	355 €	HC1-3S	SILENCIEUX (COTÉ GAUCHE)	NON	TP-OV3
 OT 4069 SSB	345 €	HC1-3SB	SILENCIEUX (COTÉ GAUCHE)	NON	TP-OV3

### SPEEDMASTER 18-19

 OT 4068 SS	355 €	HC1-3S	SILENCIEUX (COTÉ DROIT)	NON	TP-OV3
 OT 4068 SSB	345 €	HC1-3SB	SILENCIEUX (COTÉ DROIT)	NON	TP-OV3
 OT 4069 SS	355 €	HC1-3S	SILENCIEUX (COTÉ GAUCHE)	NON	TP-OV3
 OT 4069 SSB	345 €	HC1-3SB	SILENCIEUX (COTÉ GAUCHE)	NON	TP-OV3

### THRUXTON 1200 16-19

 OT 464 SS	265 €	OVC11SS	SILENCIEUX (COTÉ DROIT)	OUI	TP-OV3
 OT 464 SSB	319 €	OVC11SB	SILENCIEUX (COTÉ DROIT)	OUI	TP-OV3
 OT 465 SS	265 €	OVC11SS	SILENCIEUX (COTÉ GAUCHE)	OUI	TP-OV3
 OT 465 SSB	319 €	OVC11SB	SILENCIEUX (COTÉ GAUCHE)	OUI	TP-OV3

### TIGER 1200 12-19

 ET 4092 SS	565 €	MXT	SILENCIEUX	NON	TP-MXT80
--	-------	-----	------------	-----	----------

### VESPA

#### T-5





 ORIGINAL V 277	135 €	ORIGINAL	LIGNE COMPLÈTE	NON	NO
--	-------	----------	----------------	-----	----

#### GTS 300

 XP 0161 XS	559 €	L5X	SILENCIEUX	NON	NO
--	-------	-----	------------	-----	----

### VICTORY

#### VEGAS / HAMMER 06-16

 HV 3001 SB	375 €	HC1-2B	SILENCIEUX (SILENCIEUX SUPÉRIEUR)	NON	TP-OV3
 HV 3001 SC	389 €	HC1-2C	SILENCIEUX (SILENCIEUX SUPÉRIEUR)	NON	TP-OV3
 HV 3002 SB	375 €	HC1-2B	SILENCIEUX (SILENCIEUX INFÉRIEUR)	NON	TP-OV3
 HV 3002 SC	389 €	HC1-2C	SILENCIEUX (SILENCIEUX INFÉRIEUR)	NON	TP-OV3

### VOGE

#### 300 AC

 CV 1221 RC	329 €	RC	SILENCIEUX	NON	NO
--	-------	----	------------	-----	----

262

REFERENCE	PRIX	GAMME	DESCRIPTION	CE	INTÉRIEUR
-----------	------	-------	-------------	----	-----------

### 500 R

 CV 1220 RC	329 €	RC	SILENCIEUX	NON	NO
--	-------	----	------------	-----	----

### YAMAHA

#### WHY - MINARELLI HORIZONTAL

 YAM 2326	125 €	SCCL	LIGNE COMPLÈTE	NON	NO
--	-------	------	----------------	-----	----

#### ZEST 50-90 - MINARELLI HORIZONTAL

 YAM 2326	125 €	SCCL	LIGNE COMPLÈTE	NON	NO
--	-------	------	----------------	-----	----

#### ZUMA II - MINARELLI VERTICAL

 YAM 2334	125 €	SCCL	LIGNE COMPLÈTE	NON	NO
--	-------	------	----------------	-----	----

#### JOG 50 (3WG) - MINARELLI HORIZONTAL

 YAM 2326	125 €	SCCL	LIGNE COMPLÈTE	OUI	NO
--	-------	------	----------------	-----	----

#### NEO'S - MINARELLI HORIZONTAL

 YAM 2326	125 €	SCCL	LIGNE COMPLÈTE	NON	NO
--	-------	------	----------------	-----	----

#### SLIDER 50 - MINARELLI VERTICAL

 YAM 2334	125 €	SCCL	LIGNE COMPLÈTE	NON	NO
--	-------	------	----------------	-----	----

#### SPY 50 - MINARELLI VERTICAL

 YAM 2334	125 €	SCCL	LIGNE COMPLÈTE	NON	NO
--	-------	------	----------------	-----	----

#### AEROX - MINARELLI HORIZONTAL

 YAM 2326	125 €	SCCL	LIGNE COMPLÈTE	NON	NO
---	-------	------	----------------	-----	----

#### BREEZE - MINARELLI HORIZONTAL

 YAM 2326	125 €	SCCL	LIGNE COMPLÈTE	NON	NO
--	-------	------	----------------	-----	----

#### BUMP I / II 50 - MINARELLI VERTICAL

 YAM 2334	125 €	SCCL	LIGNE COMPLÈTE	NON	NO
--	-------	------	----------------	-----	----

#### BW'S 50 - MINARELLI VERTICAL

 YAM 2334	125 €	SCCL	LIGNE COMPLÈTE	NON	NO
--	-------	------	----------------	-----	----

#### BW'S 65 NEXT GENERATION - MINARELLI VERT.

 YAM 2334	125 €	SCCL	LIGNE COMPLÈTE	NON	NO
--	-------	------	----------------	-----	----

#### JOG 90 - MINARELLI HORIZONTAL

 YAM 2326	125 €	SCCL	LIGNE COMPLÈTE	NON	NO
--	-------	------	----------------	-----	----

#### YBR 125

 OY 9003 VSE	429 €	SOVE	LIGNE COMPLÈTE	NON	TP-OV70
---	-------	------	----------------	-----	---------

#### YZF 125 R 08-13 (RE06)

 OY 9009 VSE	489 €	SOVE	LIGNE COMPLÈTE	NON	TP-OV70
---	-------	------	----------------	-----	---------

#### MT 125 14-15

 OY 9008 VSE	489 €	SOVE	LIGNE COMPLÈTE	NON	TP-OV70
---	-------	------	----------------	-----	---------

#### WR 125 R / X 09-16 (DE07)

























 DKAT KIT 9014 C1	175 €	DKAT	DKAT - COLECTEUR	NON	NO
--	-------	------	------------------	-----	----

 OY 9014 VSE	415 €	SOVE	SILENCIEUX	OUI	TP-OV70
---	-------	------	------------	-----	---------



























applications 263



























	REFERENCE	PRIX	GAMME	DESCRIPTION	CE	INTÉRIEUR
	OY 9014 VSEB	439 €	XOVE	SILENCIEUX	OUI	TP-OV70
<b>YBR 250 12-13</b>						
	OY 920 S	415 €	2-CON	LIGNE COMPLÈTE	NON	TP-OV3
<b>R3 15-19 (R25)</b>						
	CY 9225 RC	489 €	RC	LIGNE COMPLÈTE	NON	NO
	OY 9025 VSE	565 €	SOVE	LIGNE COMPLÈTE	NON	TP-OV70
	OY 9025 VTI	729 €	VTI	LIGNE COMPLÈTE	NON	TP-OV3
<b>MT-03 15-19</b>						
	CY 9225 RC	489 €	RC	LIGNE COMPLÈTE	NON	NO
	OY 9025 VSE	565 €	SOVE	LIGNE COMPLÈTE	NON	TP-OV70
	OY 9025 VTI	729 €	VTI	LIGNE COMPLÈTE	NON	TP-OV3
<b>T-MAX DX / SX 17-18 (SJ14)</b>						
	XY 2397 XS	839 €	L5X	LIGNE COMPLÈTE	OUI	TP-OV3
<b>XJ 600 N DIVERSION (RJ01)</b>						
	OY 9045 VSE	565 €	SOVE	SILENCIEUX (2 EN 1)	OUI	TP-OV70
<b>XJ-6 09-15 (RJ19) (RJ22*)</b>						
	OY 9555 VSE	819 €	SOVE	LIGNE COMPLÈTE	OUI	TP-OV70
	SY 9755 C	999 €	SX1	LIGNE COMPLÈTE	OUI	TP-OV6
<b>FZS 600 FAZER 98-03 (RJ02)</b>						
	OY 9063 VSE	415 €	SOVE	SILENCIEUX	OUI	TP-OV70
<b>FZR 600 R 94-95 (4JHS)</b>						
	OY 9043 VSE	415 €	SOVE	SILENCIEUX	OUI	TP-OV70
<b>YZF 600 THUNDERCAT (4TV) (4CV*,4WE*)</b>						
	OY 9049 VSE	415 €	SOVE	SILENCIEUX	OUI	TP-OV70
<b>YZF 600 R-6 99-02 (RJ03)</b>						
	OY 9051 VSE	415 €	SOVE	SILENCIEUX	OUI	TP-OV70
<b>YZF 600 R-6 03-08 (RJ05)</b>						
	OY 9053 VSE	415 €	SOVE	SILENCIEUX	OUI	TP-OV70
	OY 9053 VSEB	439 €	XOVE	SILENCIEUX	OUI	TP-OV70
<b>YZF 600 R-6R 06-15 (RJ11)</b>						
	OY 9154 VSE	415 €	SOVE	SILENCIEUX	OUI	TP-OV70
<b>MT-07 14-16 (RM04)</b>						
	CY 9162 RC	849 €	RC	LIGNE COMPLÈTE	OUI	NO
	OY 962 RRB	989 €	RC1B	LIGNE COMPLÈTE	OUI	TP-OVC12
	SY 9762 C	919 €	SX1	LIGNE COMPLÈTE	OUI	TP-OV6





























	REFERENCE	PRIX	GAMME	DESCRIPTION	CE	INTÉRIEUR
	XY 9362 XB	785 €	L3XB	LIGNE COMPLÈTE	OUI	TP-HP4
<b>MT-07 17-19 (RM17,RM18)</b>						
	CY 9162 RC	849 €	RC	LIGNE COMPLÈTE	OUI	NO
	OY 962 RRB	989 €	RC1B	LIGNE COMPLÈTE	OUI	TP-OVC12
	SY 9762 C	919 €	SX1	LIGNE COMPLÈTE	OUI	TP-OV6
	XY 9362 XB	785 €	L3XB	LIGNE COMPLÈTE	OUI	TP-HP4
<b>TRACER 700 17-19 (RM14,RM15)</b>						
	CY 9162 RC	849 €	RC	LIGNE COMPLÈTE	OUI	NO
	OY 959 RRB	989 €	RC1B	LIGNE COMPLÈTE	OUI	TP-OVC12
	SY 9762 C	919 €	SX1	LIGNE COMPLÈTE	OUI	TP-OV6
	XY 9362 XB	785 €	L3XB	LIGNE COMPLÈTE	OUI	TP-HP4
<b>XSR 700 16-19 (RM11,RM12)</b>						
	CY 9162 RC	849 €	RC	LIGNE COMPLÈTE	OUI	NO
	OY 960 RRB	989 €	RC1B	LIGNE COMPLÈTE	OUI	TP-OVC12
	OY 962 SS	529 €	OVC13	LIGNE COMPLÈTE	NON	TP-OV3
	SY 9762 C	919 €	SX1	LIGNE COMPLÈTE	OUI	TP-OV6
	XY 9362 XB	785 €	L3XB	LIGNE COMPLÈTE	OUI	TP-HP4
<b>YZF 750 R (4HDS)</b>						
	OY 9061 VSE	415 €	SOVE	SILENCIEUX	OUI	TP-OV70
<b>FZ-8 10-16 (RN25)</b>						
	OY 9088 VSE	415 €	SOVE	SILENCIEUX	OUI	TP-OV70
	XY 9388 XB	449 €	L3XB	SILENCIEUX	OUI	TP-HP4
<b>TDM 850 (3VD,4TX)</b>						
	OY 9092 VSE	415 €	SOVE	SILENCIEUX (COTÉ DROIT)	NON	TP-OV70
	OY 9093 VSE	415 €	SOVE	SILENCIEUX (COTÉ GAUCHE)	NON	TP-OV70
<b>TRX 850 97-00 (4UN)</b>						
	OY 9076 VSE	415 €	SOVE	SILENCIEUX (COTÉ DROIT)	NON	TP-OV70
	OY 9077 VSE	415 €	SOVE	SILENCIEUX (COTÉ GAUCHE)	NON	TP-OV70
<b>MT-09 13-16 (RN29)</b>						
	CY 9180 RC	949 €	RC	LIGNE COMPLÈTE	OUI	NO
	FY 9880 SSB	729 €	X55SB	LIGNE COMPLÈTE	OUI	TP-X55SS
	OY 9580 VSE	839 €	SOVE	LIGNE COMPLÈTE	OUI	TP-OV70
	OY 9580 VSEB	849 €	XOVE	LIGNE COMPLÈTE	OUI	TP-OV70



























	REFERENCE	PRIX	GAMME	DESCRIPTION	CE	INTÉRIEUR
	OY 980 RRB	1.045 €	RC1B	LIGNE COMPLÈTE	OUI	TP-OVC12
	SY 9780 C	999 €	SX1	LIGNE COMPLÈTE	OUI	TP-OV6
	XY 9380 XB	889 €	L3XB	LIGNE COMPLÈTE	OUI	TP-HP4
<b>MT-09 17-19 (RN43)</b>						
	CY 9180 RC	949 €	RC	LIGNE COMPLÈTE	OUI	NO
	OY 9580 VSE	839 €	SOVE	LIGNE COMPLÈTE	OUI	TP-OV70
	OY 9580 VSEB	849 €	XOVE	LIGNE COMPLÈTE	OUI	TP-OV70
	OY 980 RRB	1.045 €	RC1B	LIGNE COMPLÈTE	OUI	TP-OVC12
	SY 9780 C	999 €	SX1	LIGNE COMPLÈTE	OUI	TP-OV6
	XY 9380 XB	889 €	L3XB	LIGNE COMPLÈTE	OUI	TP-HP4
<b>TRACER 900 13-16</b>						
	CY 9180 RC	949 €	RC	LIGNE COMPLÈTE	OUI	NO
	FY 9880 SSB	729 €	X55SB	LIGNE COMPLÈTE	OUI	TP-X55SS
	OY 9580 VSE	839 €	SOVE	LIGNE COMPLÈTE	OUI	TP-OV70
	OY 9580 VSEB	849 €	XOVE	LIGNE COMPLÈTE	OUI	TP-OV70
	OY 979 RRB	1.045 €	RC1B	LIGNE COMPLÈTE	OUI	TP-OVC12
	XY 9380 XB	889 €	L3XB	LIGNE COMPLÈTE	OUI	TP-HP4
<b>TRACER 900 17-19 (RN43)</b>						
	CY 9180 RC	949 €	RC	LIGNE COMPLÈTE	OUI	NO
	OY 9580 VSE	839 €	SOVE	LIGNE COMPLÈTE	OUI	TP-OV70
	OY 9580 VSEB	849 €	XOVE	LIGNE COMPLÈTE	OUI	TP-OV70
	OY 979 RRB	1.045 €	RC1B	LIGNE COMPLÈTE	OUI	TP-OVC12
	XY 9380 XB	889 €	L3XB	LIGNE COMPLÈTE	OUI	TP-HP4
<b>XSR 900 16-19 (RN43)</b>						
	CY 9180 RC	949 €	RC	LIGNE COMPLÈTE	OUI	NO
	OY 9580 VSE	839 €	SOVE	LIGNE COMPLÈTE	OUI	TP-OV70
	OY 9580 VSEB	849 €	XOVE	LIGNE COMPLÈTE	OUI	TP-OV70
	OY 980 RRB	1.045 €	RC1B	LIGNE COMPLÈTE	OUI	TP-OVC12
	OY 980 SS	875 €	OVC13	LIGNE COMPLÈTE	NON	TP-OV3
	SY 9780 C	999 €	SX1	LIGNE COMPLÈTE	OUI	TP-OV6
	XY 9380 XB	889 €	L3XB	LIGNE COMPLÈTE	OUI	TP-HP4

	REFERENCE	PRIX	GAMME	DESCRIPTION	CE	INTÉRIEUR
<b>TDM 900 (RN08)</b>						
	OY 9078 VSE	415 €	SOVE	SILENCIEUX (COTÉ DROIT)	OUI	TP-OV70
	OY 9079 VSE	415 €	SOVE	SILENCIEUX (COTÉ GAUCHE)	OUI	TP-OV70
<b>FZS 1000 FAZER 00-05 (RN06)</b>						
	OY 9089 VSE	415 €	SOVE	SILENCIEUX	OUI	TP-OV70
<b>FZ-1 06-14 (RN16)</b>						
	OY 9090 VSE	415 €	SOVE	SILENCIEUX	OUI	TP-OV70
<b>FZR 1000 EXUP (3GMS)</b>						
	OY 9081 VSE	415 €	SOVE	SILENCIEUX	OUI	TP-OV70
	OY 9081 VSEB	439 €	XOVE	SILENCIEUX	OUI	TP-OV70
<b>YZF 1000 THUNDERICE (45V)</b>						
	OY 9085 VSE	345 €	SOVE	SILENCIEUX	OUI	TP-OV70
	OY 9085 VSEB	375 €	XOVE	SILENCIEUX	OUI	TP-OV70
<b>YZF 1000 R-1 98-01 (RN01)</b>						
	OY 9087 VSE	415 €	SOVE	SILENCIEUX	OUI	TP-OV70
<b>YZF 1000 R-1 02-03 (RN09)</b>						
	OY 9097 VSE	415 €	SOVE	SILENCIEUX	OUI	TP-OV70
<b>YZF 1000 R-1 16-19</b>						
	CY 9286 RC	329 €	RC	SILENCIEUX	NON	NO
	OY 986 RRB	539 €	RC1B	SILENCIEUX	NON	TP-OVC12
<b>MT-10 16-18 (RN45)</b>						
	FY 9874 SSB	419 €	X55SB	SILENCIEUX	OUI	TP-X55SS
	OY 974 RR	435 €	RC1	SILENCIEUX	OUI	TP-OVC12
<b>BT 1100 BULLDOG (RP05)</b>						
	OY 9094 VSE	415 €	SOVE	SILENCIEUX (COTÉ DROIT)	OUI	TP-OV70
	OY 9095 VSE	415 €	SOVE	SILENCIEUX (COTÉ GAUCHE)	OUI	TP-OV70
<b>ZONTES</b>						
<b>X-310</b>						
	CZ 3290 RC	735 €	RC	LIGNE COMPLÈTE	NON	TP-OV3
<b>R-310</b>						
	CZ 3290 RC	735 €	RC	LIGNE COMPLÈTE	NON	TP-OV3
<b>T-310</b>						
	CZ 3290 RC	735 €	RC	LIGNE COMPLÈTE	NON	TP-OV3
<b>V-310</b>						
	SZ 3791 C	585 €	SX1	LIGNE COMPLÈTE	NON	TP-OV6
				SLIP ON		
				FULL LINE		
				BOLT ON		
				ZE 04-1		



REFERENCE	PRIX	GAMME	DESCRIPTION	CE	INTÉRIEUR
<b>DB-KILLER</b>					
 OV10-4	59 €	DB-KILLER	DB-KILLER	-	-
 OV15-4	59 €	DB-KILLER	DB-KILLER	-	-
 OV17-4	59 €	DB-KILLER	DB-KILLER	-	-
 OV17-9	59 €	DB-KILLER	DB-KILLER	-	-
 OV27-10	59 €	DB-KILLER	DB-KILLER	-	-
 OV27-9	59 €	DB-KILLER	DB-KILLER	-	-
 OV33-4	59 €	DB-KILLER	DB-KILLER	-	-
 OV33-TMAX	59 €	DB-KILLER	DB-KILLER	-	-
 OV80-10	59 €	DB-KILLER	DB-KILLER	-	-
 TP-10	59 €	DB-KILLER	DB-KILLER	-	-
 TP-11	59 €	DB-KILLER	DB-KILLER	-	-
 TP-12	59 €	DB-KILLER	DB-KILLER	-	-
 TP-15 (TP-OV10)	59 €	DB-KILLER	DB-KILLER	-	-
 TP-HP2	59 €	DB-KILLER	DB-KILLER	-	-
 TP-HP4	59 €	DB-KILLER	DB-KILLER	-	-
 TP-MXT80	59 €	DB-KILLER	DB-KILLER	-	-
 TP-OV	59 €	DB-KILLER	DB-KILLER	-	-
 TP-OV2	59 €	DB-KILLER	DB-KILLER	-	-
 TP-OV20	59 €	DB-KILLER	DB-KILLER	-	-
 TP-OV3	59 €	DB-KILLER	DB-KILLER	-	-
 TP-OV33	59 €	DB-KILLER	DB-KILLER	-	-
 TP-OV3L	59 €	DB-KILLER	DB-KILLER	-	-
 TP-OV6	59 €	DB-KILLER	DB-KILLER	-	-
 TP-OV70	59 €	DB-KILLER	DB-KILLER	-	-
 TP-OV72	59 €	DB-KILLER	DB-KILLER	-	-
 TP-OV74	59 €	DB-KILLER	DB-KILLER	-	-
 TP-OV77	59 €	DB-KILLER	DB-KILLER	-	-
 TP-OV8	59 €	DB-KILLER	DB-KILLER	-	-

REFERENCE	PRIX	GAMME	DESCRIPTION	CE	INTÉRIEUR
 TP-OV9	59 €	DB-KILLER	DB-KILLER	-	-
 TP-X55SS	59 €	DB-KILLER	DB-KILLER	-	-
<b>IRONHEAD END CAPS</b>					
 HC1-60B	59 €	HC1-60B	SLASHED SORTIE (NOIR)	-	-
 HC1-60C	69 €	HC1-60C	SLASHED SORTIE (CHROME)	-	-
 HC1-62B	69 €	HC1-62B	BOTTLE SORTIE (NOIR)	-	-
 HC1-62C	69 €	HC1-62C	BOTTLE SORTIE (CHROME)	-	-
 HC1-63B	49 €	HC1-63B	SHORT GUN SORTIE (NOIR)	-	-
 HC1-63C	49 €	HC1-63C	SHORT GUN SORTIE (CHROME)	-	-
 HC1-65B	69 €	HC1-65B	CONICAL SORTIE (NOIR)	-	-
 HC1-65C	69 €	HC1-65C	CONICAL SORTIE (CHROME)	-	-
 HC1-66B	95 €	HC1-66B	FISHTAIL SORTIE (NOIR)	-	-
 HC1-66C	99 €	HC1-66C	FISHTAIL SORTIE (CHROME)	-	-
 HC2-60B	69 €	HC2-60B	SLASHED SORTIE (NOIR)	-	-
 HC2-60C	69 €	HC2-60C	SLASHED SORTIE (CHROME)	-	-
 HC2-61B	95 €	HC2-61B	SQUARE SORTIE (NOIR)	-	-
 HC2-61C	99 €	HC2-61C	SQUARE SORTIE (CHROME)	-	-
 HC2-66B	99 €	HC2-66B	FISHTAIL SORTIE (NOIR)	-	-
 HC2-66C	99 €	HC2-66C	FISHTAIL SORTIE (CHROME)	-	-
<b>IXIL WATERPROOF BAGS</b>					
 BG013BK	65 €	BG013BK	WATERPROOF SAC 30 L. NOIR	-	-
 BG015BK	79 €	BG015BK	WATERPROOF SAC 50 L. NOIR	-	-
 BG016BK	109 €	BG016BK	WATERPROOF SAC 65 L. NOIR	-	-
 BG021BK	65 €	BG021BK	WATERPROOF SAC A DOS 35 L. NOIR	-	-
 BG022BK	79 €	BG022BK	WATERPROOF SAC A DOS 22 L. NOIR	-	-
 BG022GY	79 €	BG022GY	WATERPROOF SAC A DOS 22 L. GREY	-	-









**IXIL France**

La Roche de Chaléas  
42660 Saint Régis du Coin

TEL. 04 77 343 311 / 04 77 518 337

P: 06 845 670 12

FAX 04 77 210 492

COMMANDES: [isabelle@ixilfrance.fr](mailto:isabelle@ixilfrance.fr)

SAV: [denis@ixilfrance.fr](mailto:denis@ixilfrance.fr)

COMPTABILITE: [compta@ixilfrance.fr](mailto:compta@ixilfrance.fr)